

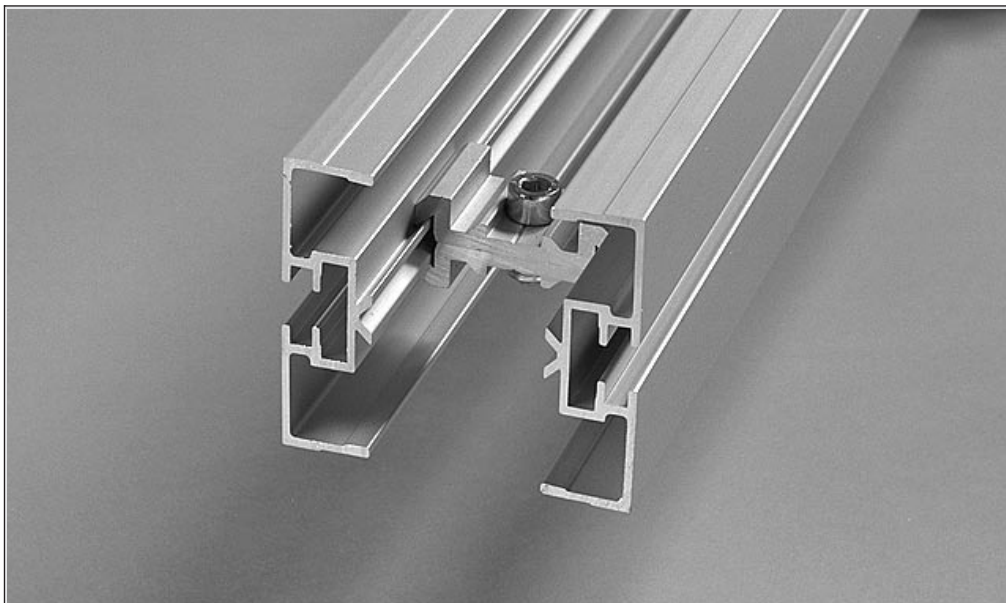

Split conveyor beam Straight sections, conveyor system XM



New beam design

The split beam is made up of two beam halves held together by beam clips. Since it consists of two separate beam halves, sections of straight split beam can be used in applications where an open beam profile is required or when twisting beams.

This bulletin presents the new split beam for conveyor system XM.

Split conveyor beam XM

Description

The split beam consists of beam profiles kept together by beam clips at regular intervals.

Split conveyor beams are primarily intended for construction of large-radius bends. They are also suitable for straight beam sections, if an open beam structure is desired, for example to facilitate efficient cleaning of the conveyor. It is also possible to use them for sections that gradually twist, for example from horizontal to sloping cross-sections.

Material specifications

Beam profile _____	Anodized aluminium
Beam clip _____	Anodized aluminium
Beam clip screws/nuts _____	Electro-zinc-plated steel
Connecting strip _____	Electro-zinc-plated steel
Slide rail _____	Polyethylene/polyvinylidene/stainless steel
Plastic screw _____	Polyamide
T-slot cover _____	Polyvinyl chloride

For detailed material specifications, see the *Technical reference* section of the FlexLink catalogue.

Tools and accessories

The beam lengths are joined together by means of standard connecting strips of the same type used with standard beams. The connecting strips are available in two lengths. Normally, the longer strip should be used. Of course, split beam sections and standard beam sections can be combined.

All four types of slide rail are suitable for the split beam. The standard mounting tool can be used.

A snap-fit plastic cover strip is available to cover the T-slots in the beam, if desired.

Ordering information

1. Determine the number of beam lengths required.
2. Determine the number of beam clips required. Normally, minimum 5 beam clips per meter should be specified. Screws and nuts are included.
3. Determine the number of connecting strips required. Two connecting strips must be ordered separately for each joint between straight beam sections.
4. Slide rail and T-slot cover should be ordered just as for standard conveyor beam.

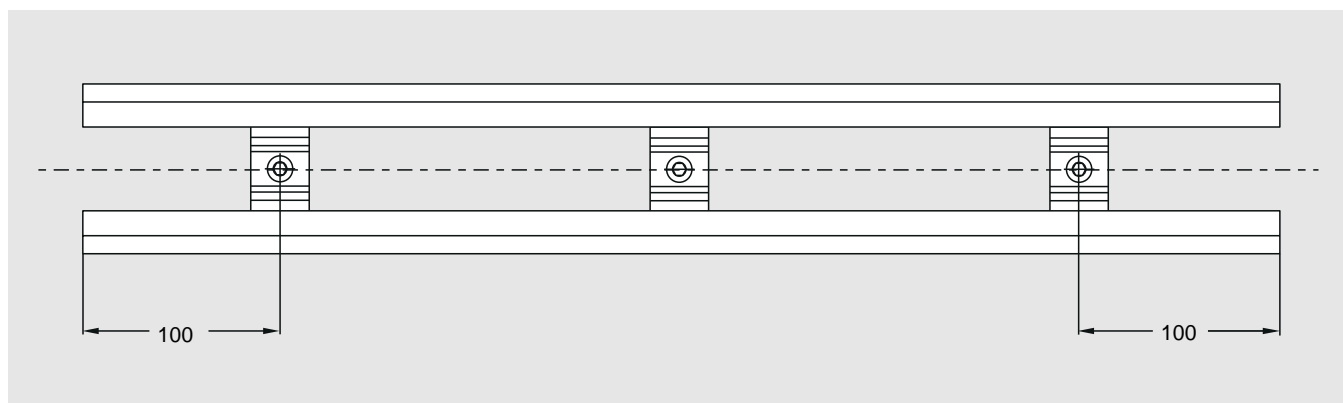
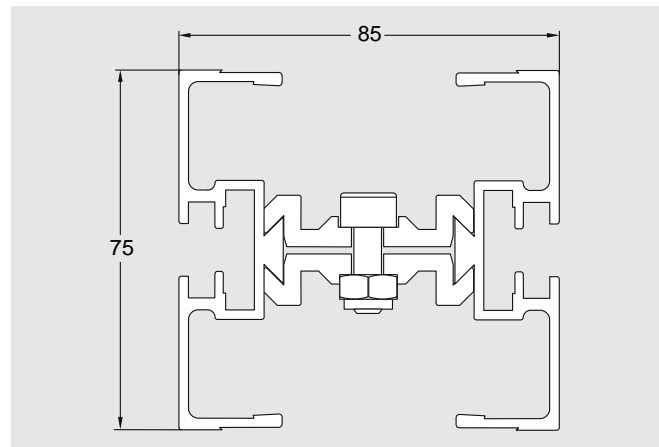

Split conveyor beam, XM

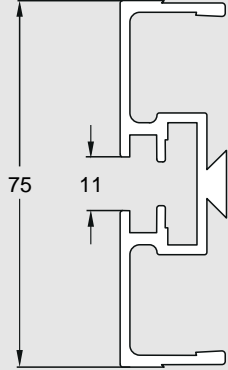
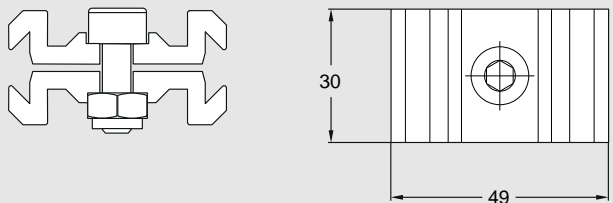
<p>XMCB 6 H XMCB 3 H XMCB L H</p>	<p>Beam profile Length 6 m Length 3 m Length to order</p>	
<p>XMCE 49x30</p>	<p>Beam clip assembly with M8x18 screw and M8 locking nut Length 30 mm</p>	

Slide rails

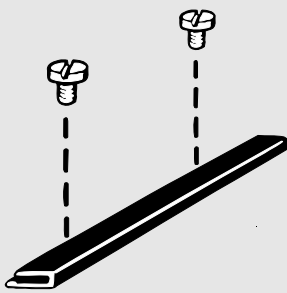
<p>XLCR 25 XLCR 25 P XLCR 25 U</p>	<p>Slide rail Length 25 m Polyethylene PVDF UHMW PE</p>	
<p>XLCR 3 TA</p>	<p>Slide rail Length 3 m Stainless steel</p>	
<p>XLAG 5</p>	<p>Plastic screw for slide rail Must be ordered in multiples of 25 (25, 50, 75,...)</p>	

Accessories

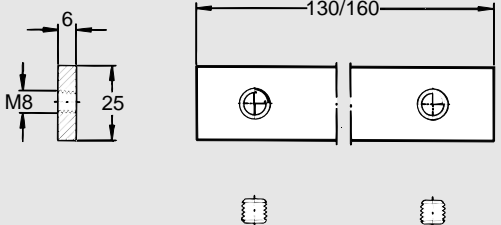
<p>XLCJ 6x130 XLCJ 6x160</p>	<p>Connecting strip with set screws Length 130 mm Length 160 mm</p>	
<p>XLAB 25</p>	<p>T-slot cover Length 25 m</p>	