

Pallet interspace divert/merge function



Standard functions from FlexLink

5336EN-1

Pallet divert/merge function re-circulates pallets on main line

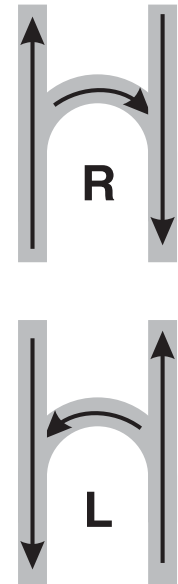

The interspace divert/merge function has the function to guide selected pallets within a main conveyor track.

The interspace divert/merge function permits re-circulating of the pallets in different loops within a main conveyor or highway. The function can be delivered in components or as a complete functional unit including all required hardware such as conveyor beams, guide rails, pallet stops, sensor brackets, sensors and RFID reader. The function has fixed outer dimensions with a clearly defined interface to the surrounding conveyors.

Each merge function is designed individually using the FlexLink ordering tool.

Standard features

- One 180° wheel with inverter controlled gear motor.
- Conveyor beams with connecting strips at the ends
- Guide rails with connecting strips at the ends
- One divert device
- Two pallet stops

Options

The following options must be specified during the configuration process:

- Pallet size
- Left or right (photo shows right-hand version)
- Guide rail width 42 mm or 101 mm
- SICK sensors included
- Sensor brackets
- M12 or M18 sensors
- Sensor type on cylinders
- RFID reader

Conveyor chain and slide rails must be ordered separately.

Basic dimensions

See next page.

Pallet interspace divert/merge function

Basic dimensions

Right-hand version

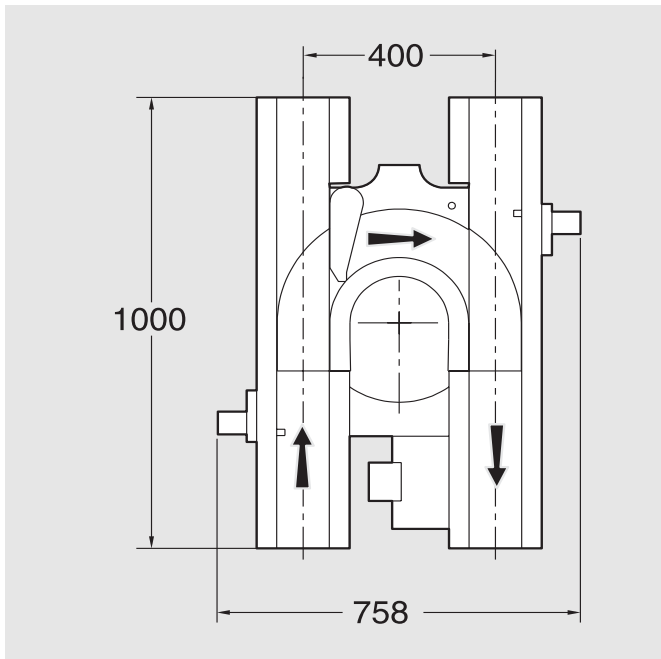

For more detailed information, see the FlexLink catalogue, sections XK and XKP.

Ordering information

For more information, and for access to the FlexLink ordering tool, please contact your local FlexLink office.

FlexLink on the internet: <http://www.flexlink.com>.

For more information, please contact your local FlexLink sales unit. Specifications are subject to change without notice.