

Packet incline units



The incline units enables gentle and effective elevating of cigarette packs at a speed of up to 400 packs per minute.

Due to high production demands vertical transport of the cigarette packets with a maximum conveyor speed of 60 m/minute is required. To achieve vertical transport on a plain or flocked chain the conveyor is equipped with soft pressure rollers fitted to a pressure bar. This solution will enable elevation without interruption and transfer between conveyors before and after the incline.

It is possible to adjust the pressure bar to allow for different pack heights. Various radius vertical bends can be supplied including 300 mm, 500 mm, and 1000 mm, depending on product needs.

Standard incline angles of 45 or 90 degrees can be supplied, with angles of 60 and 75 degrees as an option.

Standard features

- No interruption of the main conveyor
- No additional drive units required
- Easily fitted to an existing system
- Smooth handling of product
- Requires minimal gap between packs
- No additional controls required
- No friction chain required
- Can be used to incline or decline packets

Incline conveyor

Standard parts

All conveyor parts are selected from our standard catalogue for the XL system. The standard parts used in the incline conveyor are:

- Conveyor beam XLCB 3
- Slide rail XLCR 25 H
- Plain chain XLTP 5 or 5047490 (flocked)
- Vertical bend XLBV 45R**** or XLBV 90R****
- Guide rail XLRS 3x15
- Guide rail cover XLRT 3x23
- Guide rail bracket XLRB 42x18 V
- Guide rail clamp support XLRL 18x60 CA
- Guide rail clamp XLRK 18x60 C

Standard parts not included.

Ordering information

Sponge wheel

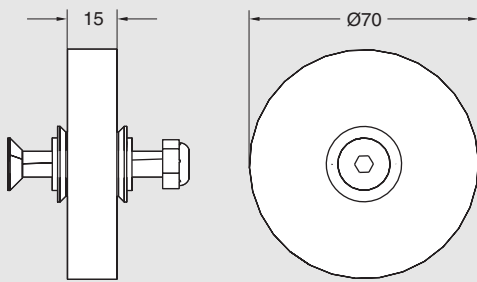

Sponge roller

Full roller assembly including hub and fixings, 1 pc	5111461
Sponge roller only, 50 pcs	5111472

Pressure bar

The length of the pressure bar is determined by the incline height required for the application.

The distance between centres of the soft wheels is 80 mm. The brackets holding the pressure bar have a distance between centres of approximately 800 mm.



For more information, please contact your local FlexLink sales unit. Specifications are subject to change without notice.