

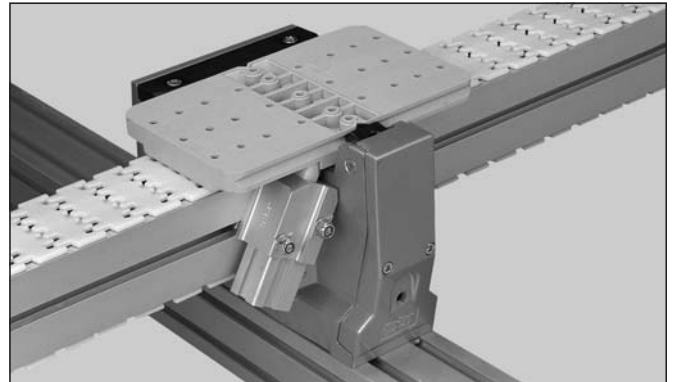

Pallet locating station – XM

Contents

<i>Pallet locating station</i>	
XMPX 150 A _____	2
<i>Revision list</i> _____	3



Pallet locating station

XMPX 150 A

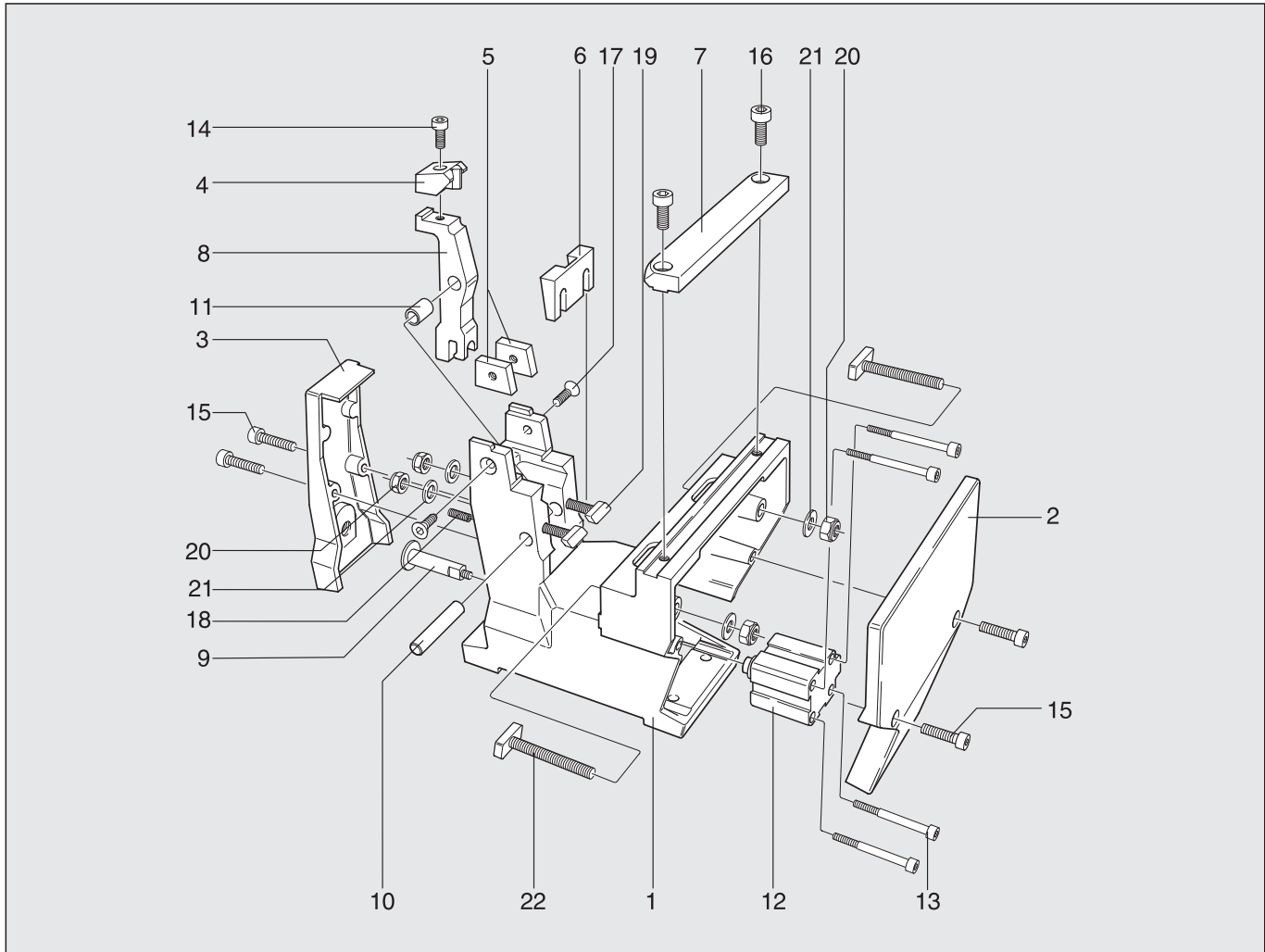

Item	Description	Part No	Qty	Comments
1	Base	3921308	1	
2	Cover	3921309	1	
3	Cover	3921310	1	
4	Locating plunger	3921311	1	
5	Slide block	3921312	1	
6	Locking wedge	3921313	1	
7	Guide rule	3921338	1	
8	Arm	3904798	1	
9	Rod end XM	5052825	1	
10	Cylinder pin	CP-h8-10x60	1	
11	Sleeve (Note: Initial lubrication required)	GLY.PG 101220 A	1	
12	Air cylinder FESTO	ADVC 32-10-I-P-A	1	
13	Screw	MC6S 5x50	4	
14	Screw	MC6S 6x20	1	
15	Screw	MC6S 6x25	4	
16	Screw	MC6S 8x16	2	
17	Screw	MF6S 6x16	2	
18	Screw	SK6SS 6x16	1	
19	T-slot screw	XLAT 71	4	
20	Nut	XLAN 8	4	
21	Washer	BRB 8,4x16	4	
22	Screw	XLAT 53	2	

