

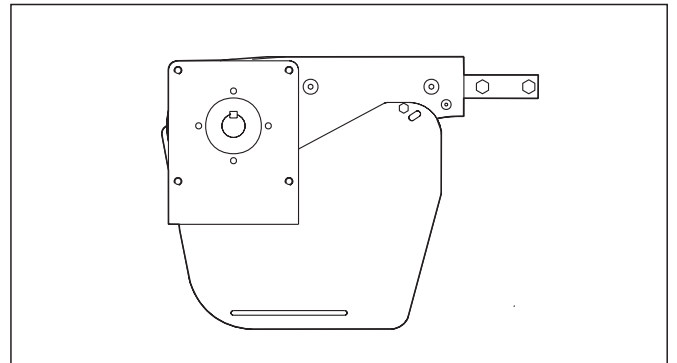

End drive unit for stainless steel conveyor – XM

Contents

<i>End drive unit for stainless steel conveyor</i> _____	2
<i>0-unit – XMEBX 0 HLP/HRP</i> _____	2
<i>Revision list</i> _____	3



End drive unit for stainless steel conveyor

0-unit – XMEBX 0 HLP/HRP

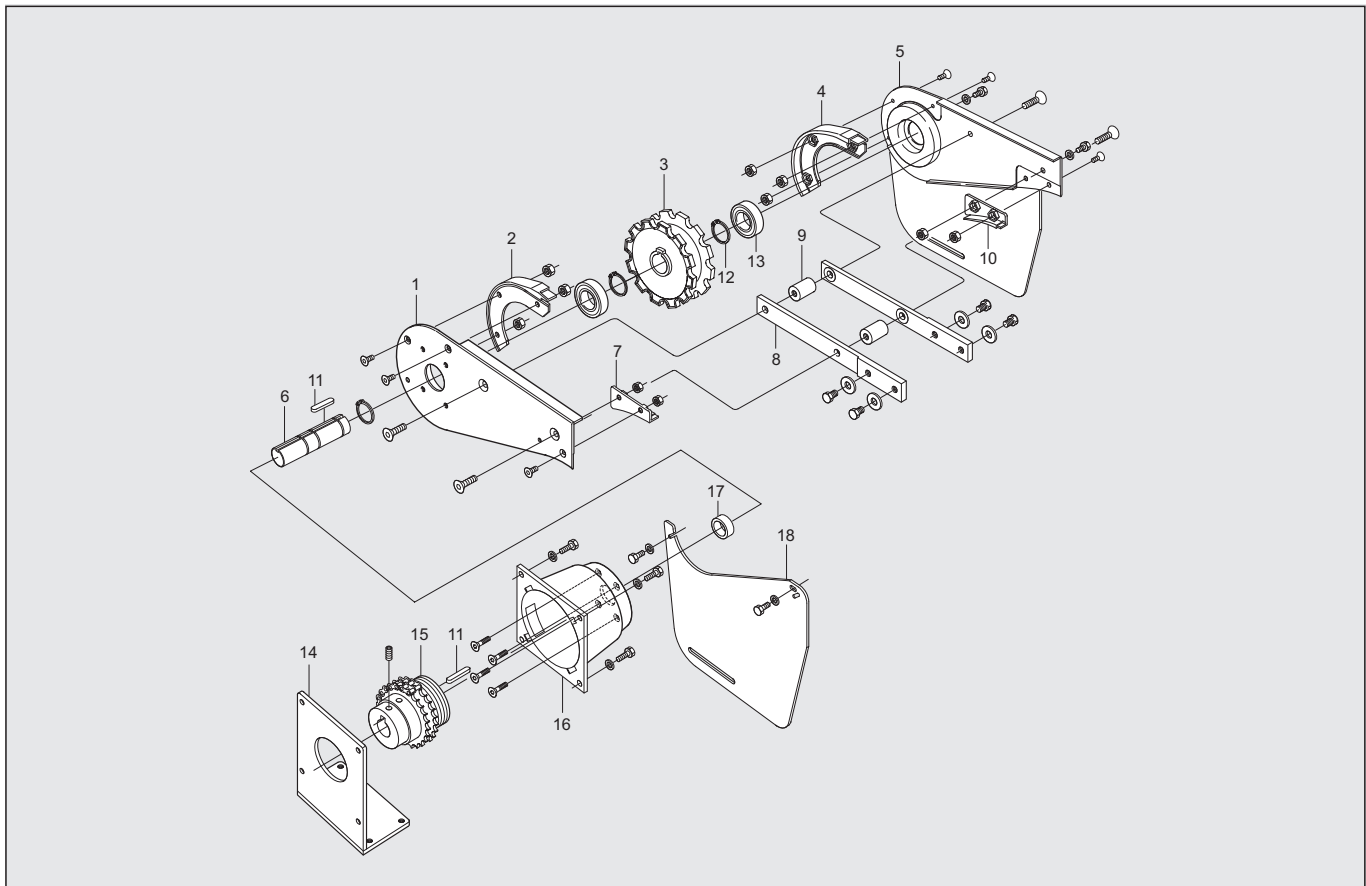

Item	Description	Part No	Qty	Comments
1Side plate L (XMEBX 0 HLP)	5048530	1
Side plate L (XMEBX 0 HRP)	5048533	1
2Steering guide L.....	3924693	1☆
3Drive wheel	3924691	1☆
4Steering guide R.....	3924692	1☆
5Side plate R (XMEBX 0 HLP)	5048531	1
Side plate R (XMEBX 0 HRP)	5048532	1
6Shaft.....	3920991	1
7Guide L	3924695	1☆
8Connecting strip	5048537	2
9Spacer.....	5049456	2
10Guide R.....	3924694	1☆
11Wedge	8x7-40 PK A4	2
12Retaining ring.....	SgA 25 A2	3
13Bearing	6205-2RS1/C3-A4	2
14Adapter plate.....	5049482	1
15Slip clutch.....	5054004	1
16Flange	5048551	1
17Spacer.....	5048663	1
18Slack protection	5049346	2

☆ = Recommended spare part

