



End drive unit XHEH H



End drive unit with overhead transmission

Drive units with overhead transmission can be used if there is a lack of space underneath the conveyor, or if there is a risk that oil or other fluids will drip on to the drive unit.

End drive unit XHEH H is delivered with overhead transmission and with transmission either on the left- or right-hand side.

End drive units

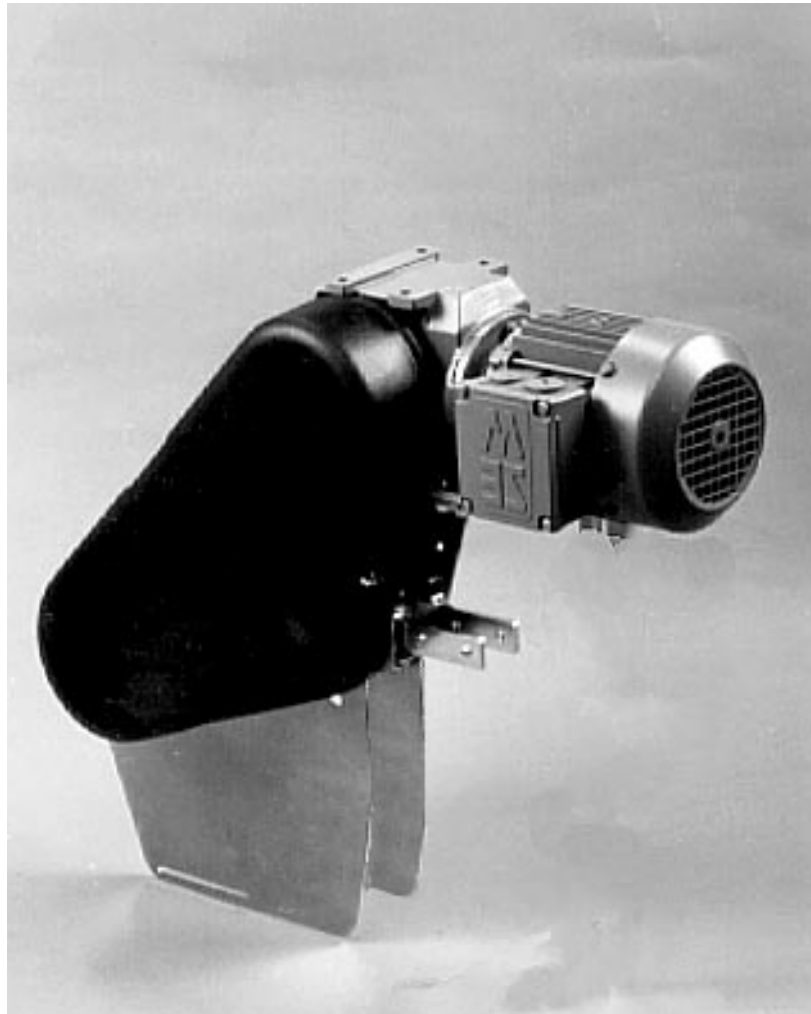

Description

The end drive unit is designed to be positioned at one end of the conveyor. The worm gear motor drives the conveyor chain via a chain transmission system with an adjustable slip clutch. (Clutch adjustment: see Appendix B in catalogue section APX.)

The drive unit is available with overhead motor and transmission on left- or right-hand side.

The transmission chain tension is controlled by a chain stretching device with an adjustment screw. To ensure access to the adjustment screw, the first 300 mm of the conveyor beam must not be used for fitting of supports, etc.

For effective protection against personal injury, the drive unit is equipped with a transmission cover. The cover shall always be in place when the conveyor is running.

Note!

When using a drive unit with overhead transmission, safeguarding is especially important since the risk of getting caught is greater than when using a suspended motor.

Material specifications

Standard motor _____	3-phase 400 V
Number of teeth on drive wheel ___	12
Chain pitch _____	35,5 mm
Pitch diameter _____	137,2 mm
Maximum traction force _____	1250 N

The following standard speeds are available (50 Hz):
5, 10, 15, 20, 30, 40, 50, 60 m/min.

The motors can be run on 440–460 V and 60 Hz. The speed is then 20 % higher.

Other motor alternatives are available.

Ordering information

- 1 Select the most suitable drive unit configuration.
- 2 Calculate the actual load and compare with the capacity of the drive unit.
- 3 The chain speed is denoted by the digit (for example 5) in the designation code. Other chain speeds are available on request.

End drive units

XHEH 5 HL

Drive unit
Overhead motor
Transmission on
left-hand side

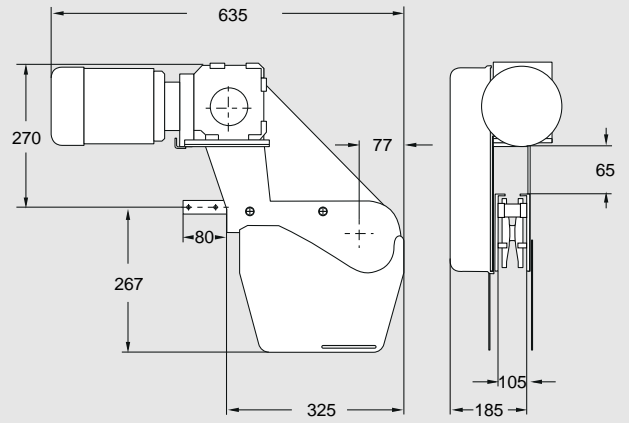

XHEH 5 HR

Drive unit
Overhead motor
Transmission on
right-hand side

