

PO  
 X45  
 XS  
 XL  
 XLP  
 X85  
 X85P  
 XH  
 XK  
 XKP  
 X180  
 X300  
 GR  
 CS  
 XT  
 WL  
 XC  
 XF  
 XD  
 XLX  
 X85X  
 X180X  
 X300X  
 GRX  
 CSX  
 ELV  
 CTL  
 FST  
 TR  
 APX  
 IDX

# XK pallet handling components

## System information



### Pallet handling components for conveyor system XK

The pallet handling components for conveyor system XK satisfy the demands for a sturdy pallet conveyor for medium to heavy loads in demanding environments. Heavy-duty conveyor beams, sturdy product carriers (pallets), and a strong chain permit item weights up to 30 kg. The maximum size of the products on the pallets depends on the shape of the products and the location of their centre of gravity. Robust side support components permit accumulation up to 200 kg per stop device, even in wheel bends.

### Divert/merge devices

Divert/merge devices are used for routing products by dividing or combining flows of products.

### RFID functions

All pallets are equipped with sockets for RFID chips. System components for automatic pallet handling are available. Please contact FlexLink Systems for more information

### Chain for XK pallet handling

A special chain type XKTP 5 A was developed for use with the XK pallet handling system. Since XKTP 5 A can also be used in non-pallet systems, it is listed under

“Conveyor chains” in catalogue section “Conveyor system XK”.

The standard plain chain XKTP 5 cannot be used.

### Examples of application areas

Transport and assembly of pistons, water taps, connecting rods, ball and roller bearings, gear wheels, crankshafts, and hydraulic pumps.

### Function modules

Several pre-designed function modules, including merge, divert and locate functions, can be ordered using the online configuration tool. Please contact FlexLink Systems for more information.

### Pallet loading

The centre of gravity of the product on the pallet (including fixture) must be located inside a 40 mm x 140 mm rectangle on the pallet. See figure.

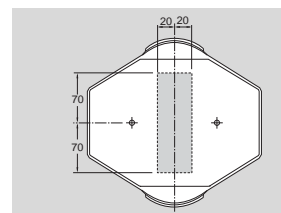

### Technical characteristics

Pallet sizes (WxLxH) ..... 200 mm x 150 mm x 53 mm  
 250 mm x 225 mm x 53 mm  
 300 mm x 300 mm x 53 mm  
 Max. load on pallet..... 30 kg (including pallet and fixture)

## Pallet 200×150 with RFID socket

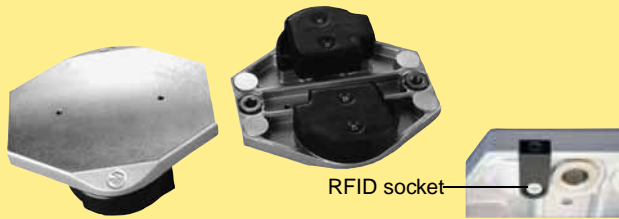

Pallet 200 mm × 150 mm **XKPP 200×150 A**

Fully assembled unit, including two guide discs and RFID socket.

Weight: 1,4 kg.

Pallet plate: cast aluminium.

Guide disc: acetal resin POM.

See page 219 for detailed pallet dimensions.

## Pallet 250×225 with RFID socket

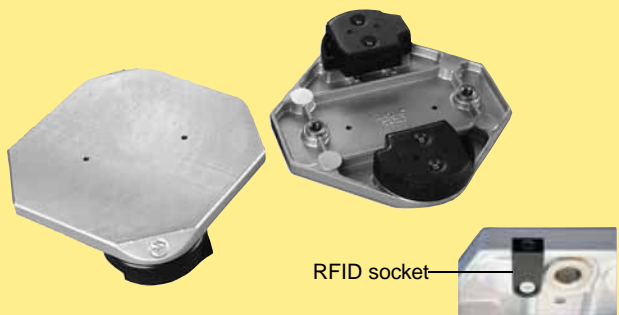

Pallet 250 mm × 225 mm **XKPP 250×225 A**

Fully assembled unit, including two guide discs and RFID socket.

Weight: 1,8 kg.

Pallet plate: cast aluminium.

Guide disc: acetal resin POM.

See page 219 for detailed pallet dimensions.

## Pallet 300×300 with RFID socket

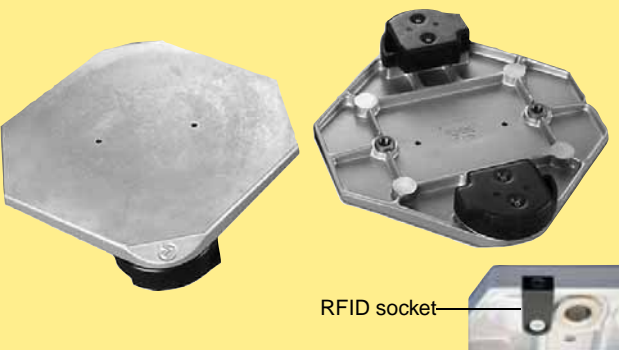

Pallet 300 mm × 300 mm **XKPP 300×300 A**

Note. This pallet cannot be accumulated through 180° bends.

Fully assembled unit, including two guide discs and RFID socket.

Weight: 2,3 kg.

Pallet plate: cast aluminium.

Guide disc: acetal resin POM.

See page 220 for detailed pallet dimensions.

Damped guide disc XKPG D105 A is particularly useful:

- for conveyor speeds  $\geq 10$  m/min to reduce noise from collisions between pallets
- to reduce shock for sensitive products
- to reduce the total queue pressure that arises when stopping longer, heavier pallet queues

and includes guidance towards the pallet plate and to be more wear resistant it also includes a steel insert, placed where the stop arm acts.

## Ordering information

Damped guide discs have to be ordered as a complement. Standard pallets (XKPP) cannot be ordered including damped guide discs. However, standard pallets can easily be rebuilt according to below.

### Mounting methods

The damped guide discs can be mounted in two different ways:

Method 1 – Only front disc replaced to damped version

Function:

- Shock reduction between pallets.

Method 2 – Both front and rear disc replaced to damped versions.

Function:

- Further improved shock reduction between pallets compared to method 1.
- Reduction of the total queue pressure that arises when stopping a longer, heavier pallet queues.

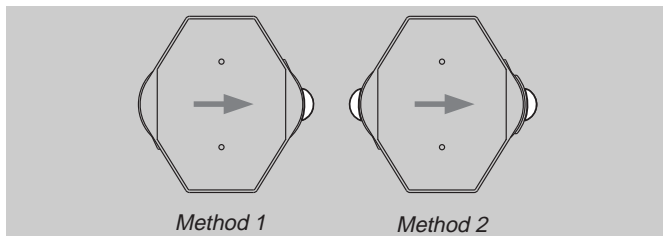

When a pallet hits another pallet the nose will be pressed into the guide disc, thereby transmitting the force perpendicular towards the guide rails.

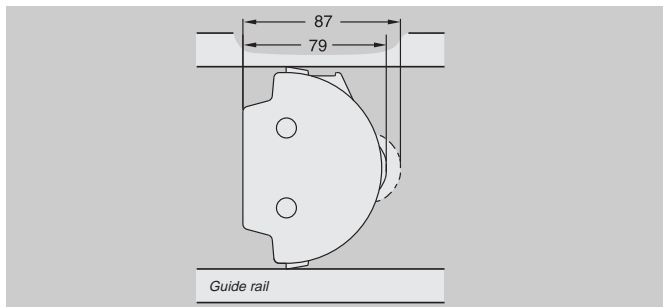

**Note!**

Use optical sensors for max. queue indication instead of a proximity sensor toward a pallet sensor plate.

## Guide disc with integrated damping function

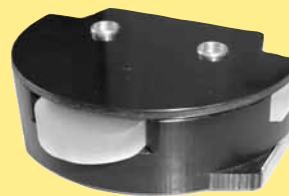

Guide disc with damping

**XKPG D105 A**

Body: acetal resin POM.

Shock absorber: polyurethane.

Weight: 0,38 kg.

See page 220 for detailed guide disc information.

Including screws, slide plate, shock absorber.

Note. The previous version of this product

(**XKPG D105**) can be ordered as a spare part.

## Guide disc for pallet

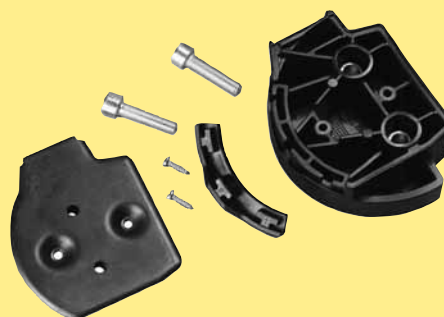

Guide disc

**XKPG 105 A**

Body: acetal resin POM

Weight: 0,24 kg

See page 220 for detailed guide disc information.

Including screws, slide plate, shock absorber.

Note. The previous version of this product

(**XKPG 105**) can be ordered as a spare part.

## Slide plate for pallet

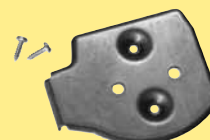

Slide plate

**XKPS 105**

Steel. Including screws

## Shock absorber for pallet



Shock absorber  
Polyurethane

**3926430**

PO  
X45  
XS  
XL  
XLP  
X85  
X85P  
XH  
XK  
XKP  
X180  
X300  
GR  
CS  
XT  
WL  
XC  
XF  
XD  
XLX  
X85X  
X180X  
X300X  
GRX  
CSX  
ELV  
CTL  
FST  
TR  
APX  
IDX

## RFID components

### RFID tag

The RFID tag can be read reliably at speeds up to 30 m/min. The tag has an M5 grub screw like design and is mounted in a plastic holder.

Threaded type	M5x16,5mm
Operating frequency	125 kHz
Memory [BIT]	224 (7 pages with 32 bits each)

### RFID tag



RFID tag

**5058153**

<sup>1)</sup> The RFID tag holder is included in all pallets

### Read/write head

The read/write heads exchange data with the passive RFID tags at a maximum distance of 20 mm. The read/write head has an M12 connector. The M12 cable is connected to an M12 ASi socket. Up to 31 read/write heads can be connected to one ASi system.

### Read/write head



Read/write head

**5058152**

### Read/write head bracket

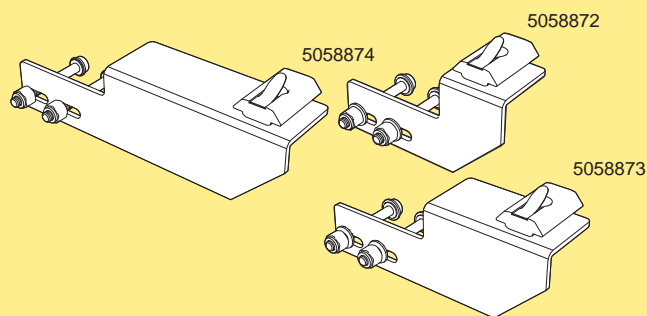

Read/write head bracket

for pallet XKPP 200x150 A

**5058872**

for pallet XKPP 250x225 A

**5058873**

for pallet XKPP 300x300 A

**5058874**

*Including mounting details.*

- PO
- X45
- XS
- XL
- XLP
- X85
- X85P
- XH
- XK
- XKP**
- X180
- X300
- GR
- CS
- XT
- WL
- XC
- XF
- XD
- XLX
- X85X
- X180X
- X300X
- GRX
- CSX
- ELV
- CTL
- FST
- TR
- APX
- IDX



### XKPP 200×150 A

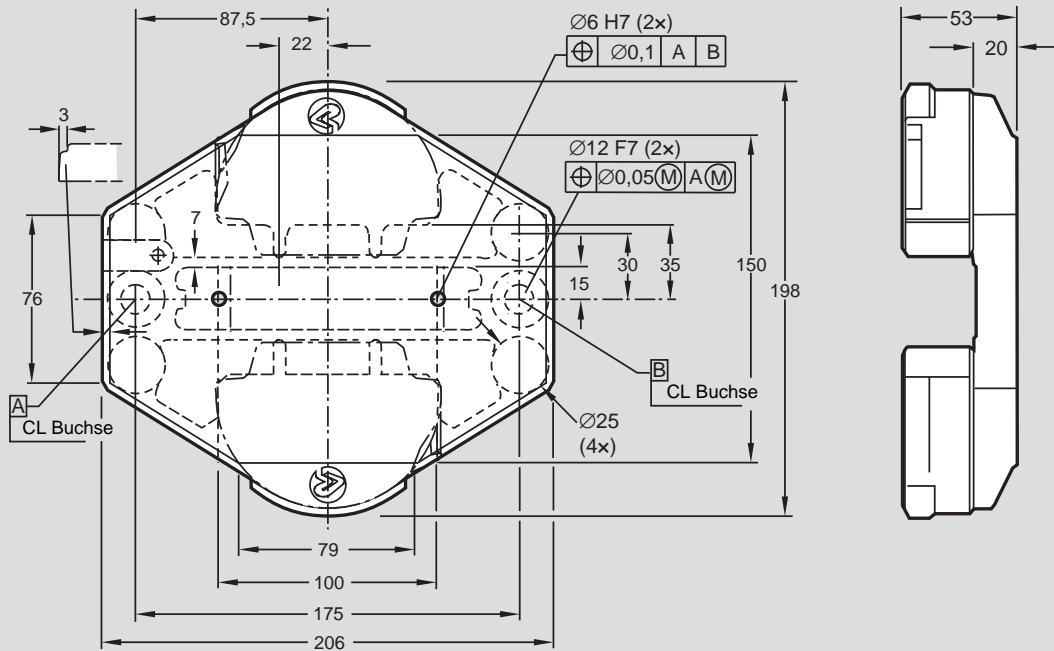

### XKPP 250×225 A

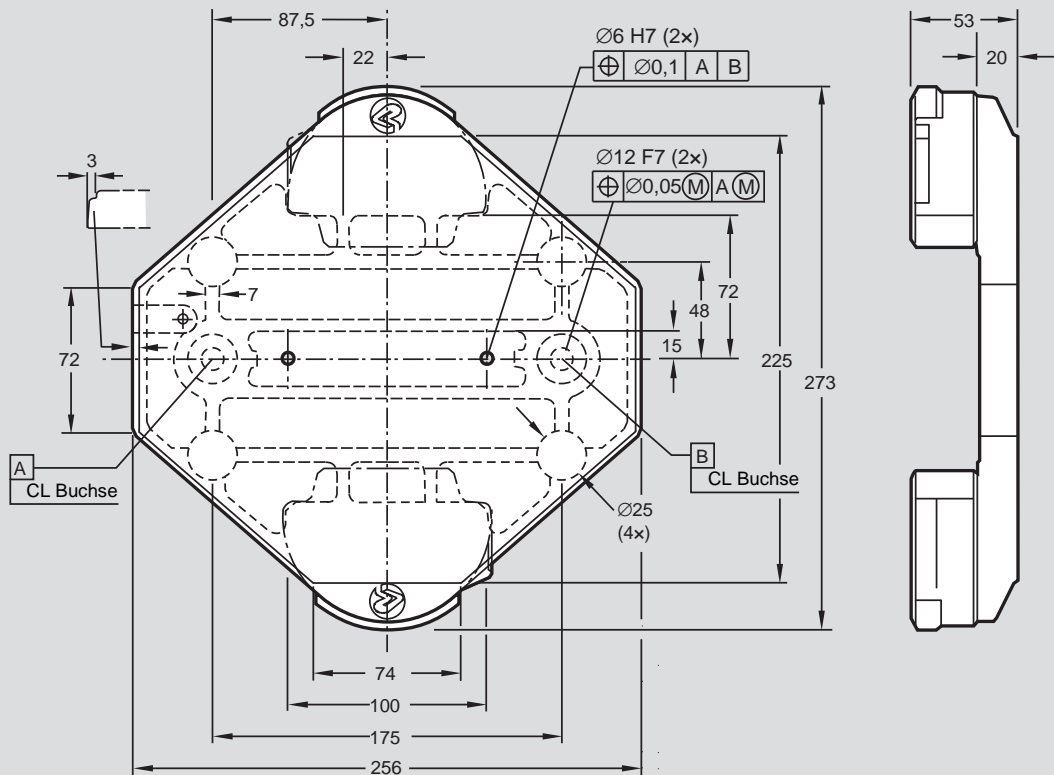



XKPP 300×300 A

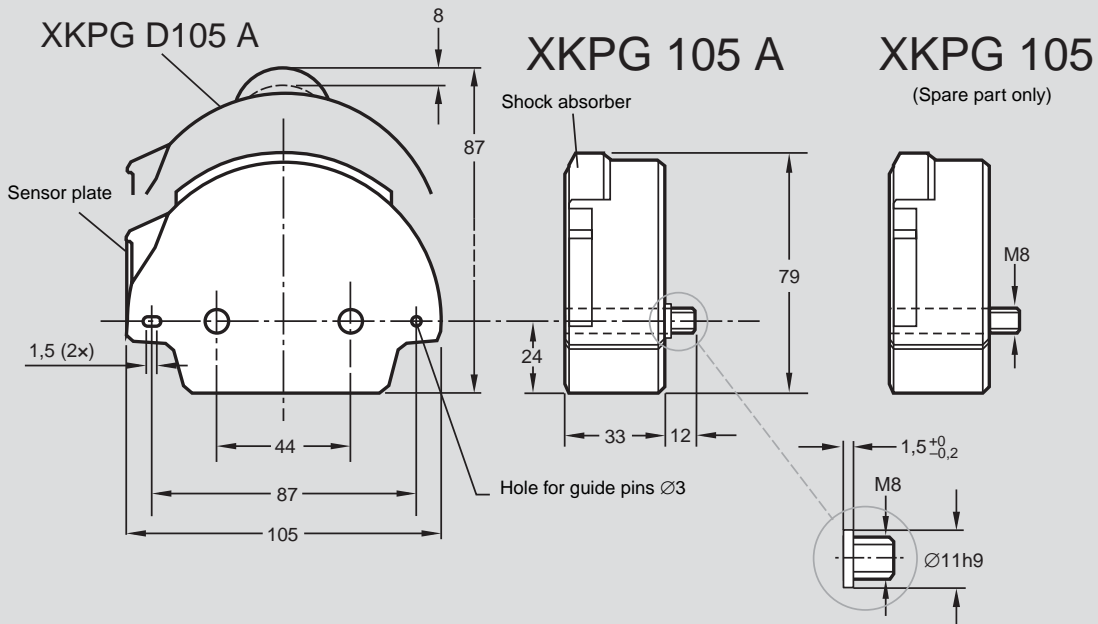
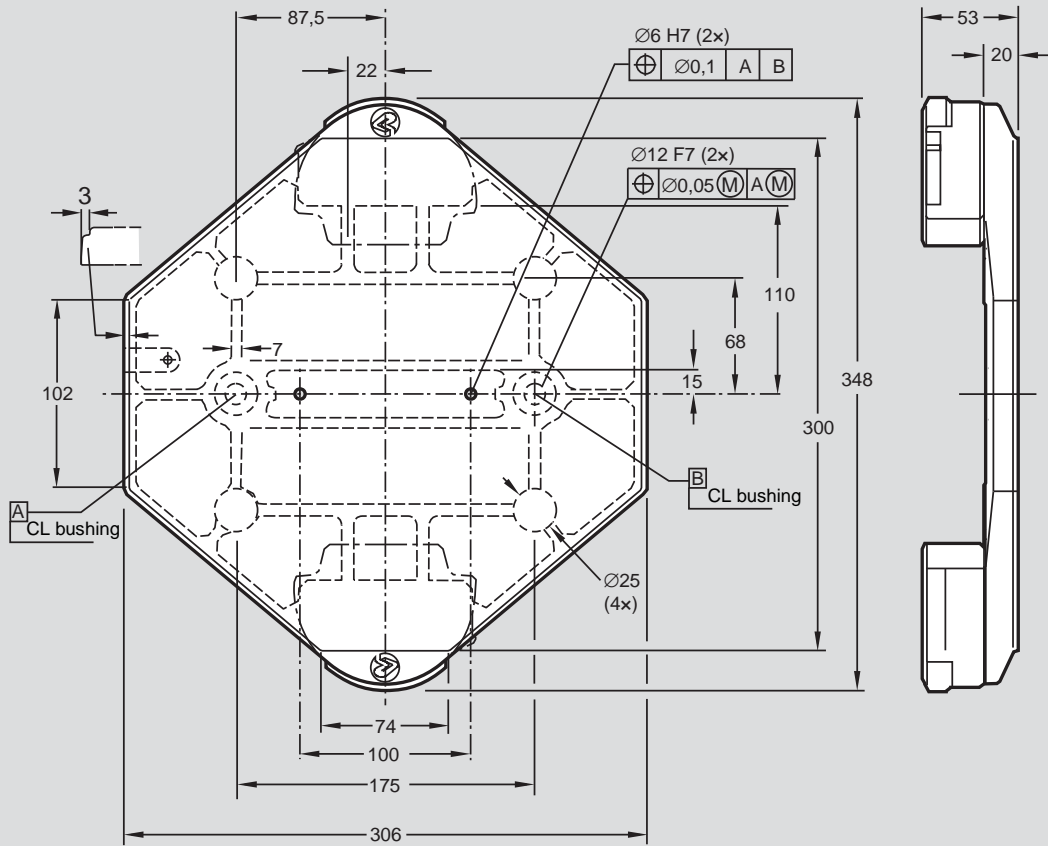

# Slide rails

**Slide rails**

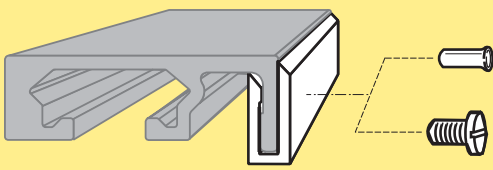

Slide rail  
 Length 25 m  
 UHMW-PE (White)  
 PVDF (Natural white)  
 PA-PE (Grey)

**XKCR 25 U**  
**XWCR 25 P**  
**XKCR 25 H**

Plastic screw for slide rail **XWAG 5\***  
 Aluminium rivet (brown colour) **XLAH 4x7\*\***

*\*Note. Must be ordered in multiples of 50*  
*\*\*Note. Must be ordered in multiples of 250*

**Rivet crimping pliers**



Rivet crimping pliers  
 For 4 mm rivets

**5051395**

**Rivet crimping clamp**

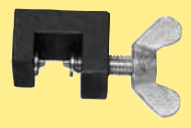

Rivet crimping clamp  
 For 4 mm rivets

**3923005**

# Guide rails (dry applications)

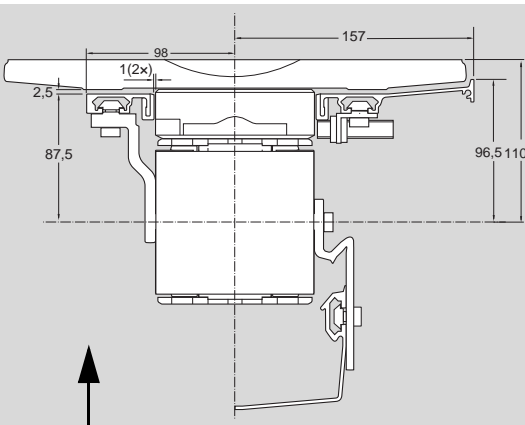

↑  
 Guide rails for dry applications

**Straight guide rail**

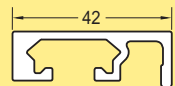

Guide rail  
 Length 3 m

**XKRS 3x42**

Guide rail bracket: see page 223.

**Guide rails for pallets in bends 30°**

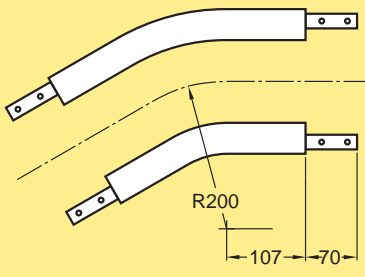

Guide rail for pallets in bends  
 Outer guide rail, 30° **3927174**  
 Inner guide rail, 30° **3927170**

Including connecting strips

**Guide rails for pallets in bends 45°**

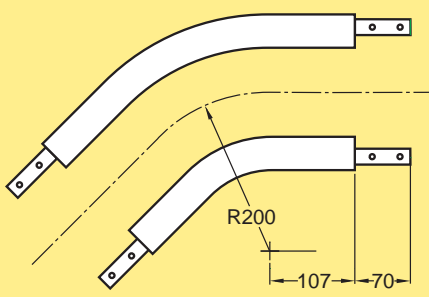

Guide rail for pallets in bends  
 Outer guide rail, 45° **3927173**  
 Inner guide rail, 45° **3927169**

Including connecting strips

PO  
 X45  
 XS  
 XL  
 XLP  
 X85  
 X85P  
 XH  
 XK  
 XKP  
 X180  
 X300  
 GR  
 CS  
 XT  
 WL  
 XC  
 XF  
 XD  
 XLX  
 X85X  
 X180X  
 X300X  
 GRX  
 CSX  
 ELV  
 CTL  
 FST  
 TR  
 APX  
 IDX

## Guide rails (dry applications, continued)

### Guide rails for pallets in bends 90°

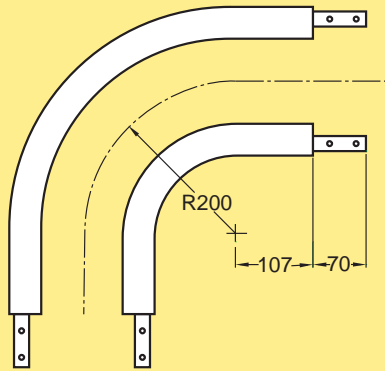

Guide rail for pallets in bends

Outer guide rail, 90°

**3927172**

Inner guide rail, 90°

**3927168**

*Including connecting strips*

### Guide rails for pallets in bends 180°

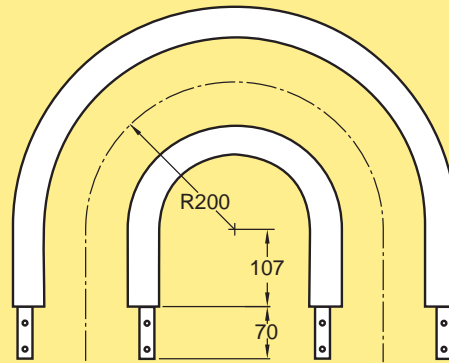

Guide rail for pallets in bends

Outer guide rail, 180°

**3927171**

Inner guide rail, 180°

**3927167**

*Including connecting strips*

## Drip catchers (wet applications)

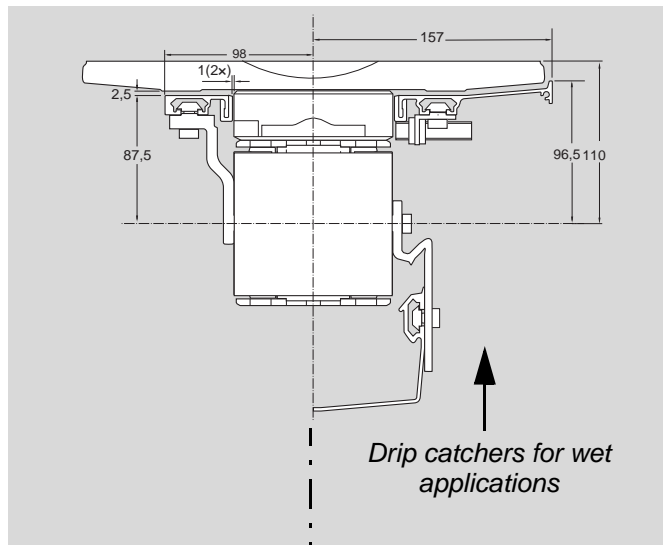

*Drip catchers for wet applications*

### Drip catcher for wheel bend 30°

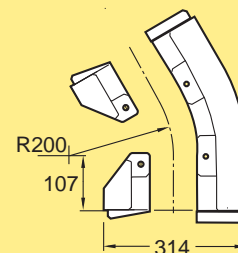

Drip catcher kit for 30° bend

**XKDW 30R355**

*ABS plastic. Including screw kit*

### Drip catcher for wheel bend 45°

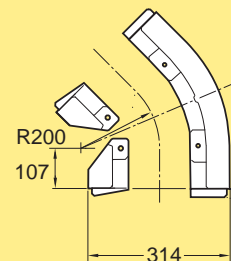

Drip catcher kit for 45° bend

**XKDW 45R355**

*ABS plastic. Including screw kit*

### Straight guide rail with drip catcher

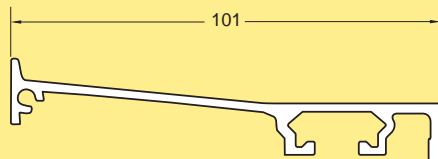

Guide rail with drip catcher

Length 3 m

**XKRS 3x100**

*Guide rail bracket: see page 223.*

PO  
X45  
XS  
XL  
XLP  
X85  
X85P  
XH  
XK  
XKP  
X180  
X300  
GR  
CS  
XT  
WL  
XC  
XF  
XD  
XLX  
X85X  
X180X  
X300X  
GRX  
CSX  
ELV  
CTL  
FST  
TR  
APX  
IDX

**Drip catcher for wheel bend 90°**

Drip catcher kit for 90° bend **XKDW 90R355**  
ABS plastic. Including screw kit

**Drip catcher for wheel bend 180°**

Drip catcher kit for 180° bend **XKDW 180R355**  
ABS plastic. Including screw kit

**Drip trays**

Drip tray  
Length 3 m **XKDT 3x147**  
See page 212 for more information.

**Accessories and tools**

**Guide rail bracket**

Guide rail bracket for XK pallets **XKRB 30x74**  
Note. Designed for use with chain XKTP 5 A. Chain XKTP 5 cannot be used for XK pallet handling.

**Mounting toolkit for guide rail**

Mounting toolkit for guide rail **3926757**  
Use the kit to ensure that the guide rails are attached with a correct and consistent spacing. Including assembly instructions

**Connecting strips for XK guide rails**

Connecting strips for XK guide rails **3924731**  
Two connecting strips with screws

**Set screw (used as guide pin)**

Set screw, ISO 7436: 1983 M4x 20 **SK6SS 4x20**  
Note. Must be ordered in multiples of 50

## Pallet locating station

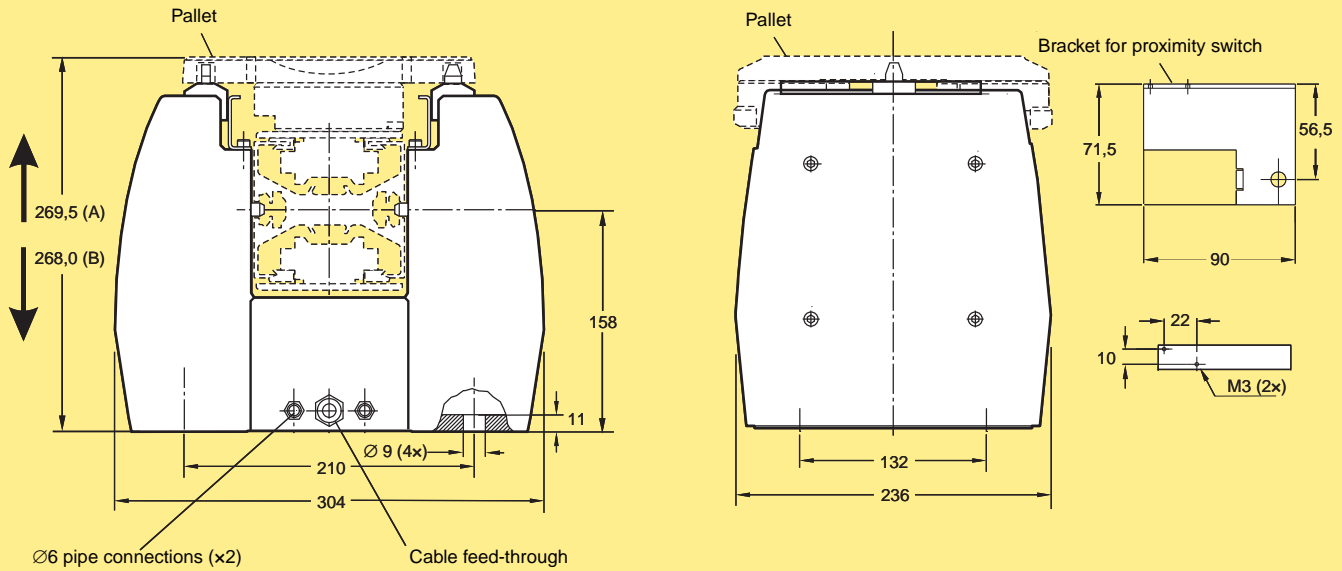

## Pneumatic locating station

(A) = located, (B) = non-located.

*Note.* Designed for use with chain XKTP 5 A. Chain XKTP 5 cannot be used for XK pallet handling. Frame: cast aluminium. Rulers and guide pins: hardened steel.

Locating accuracy:  $\pm 0,1$  mm. Maximum vertical force per ruler at 0,6 MPa: 600 N including pallet weight. The locating station should be installed on a separate support which is not rigidly connected to the conveyor beam.

Specify the locating station with guide rails with or without drip catcher.

Proximity switches are not supplied by FlexLink Systems. To indicate "pallet ready to lift", a SICK proximity switch (IQ 10 series, sensing range 6 mm) or similar can be used. See figure below.

## XKPX 175 A

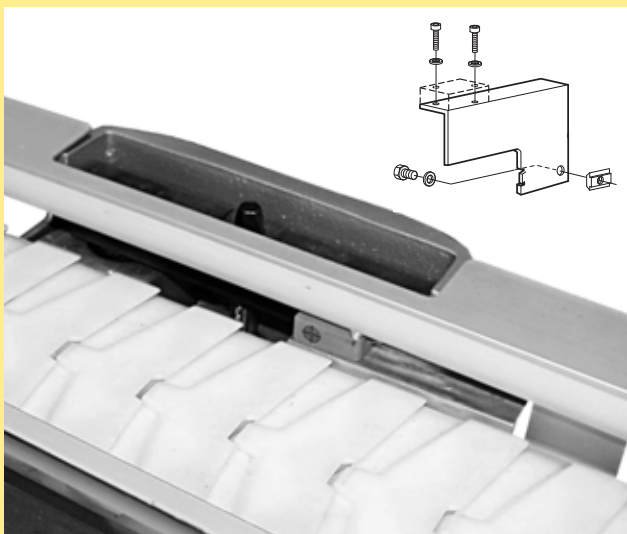
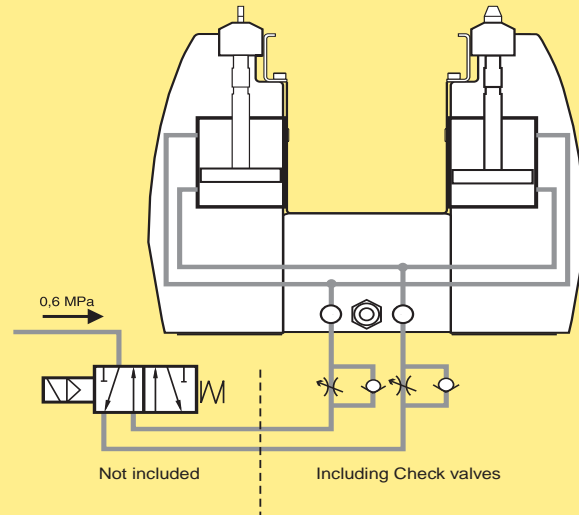

Two  $\varnothing 12$  holes are prepared in the locating station for additional proximity switches, to indicate lifting of the pallet.

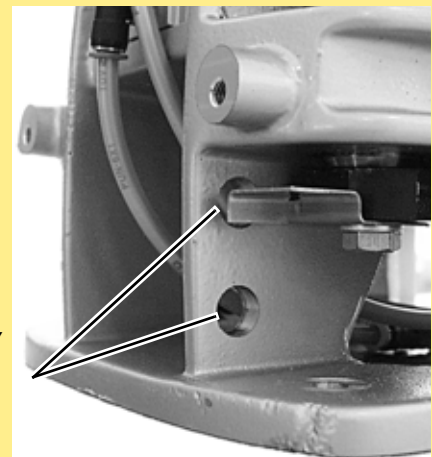

PO  
X45  
XS  
XL  
XLP  
X85  
X85P  
XH  
XK  
XKP  
X180  
X300  
GR  
CS  
XT  
WL  
XC  
XF  
XD  
XLX  
X85X  
X180X  
X300X  
GRX  
CSX  
ELV  
CTL  
FST  
TR  
APX  
IDX

**Guide rail kit for locating station**

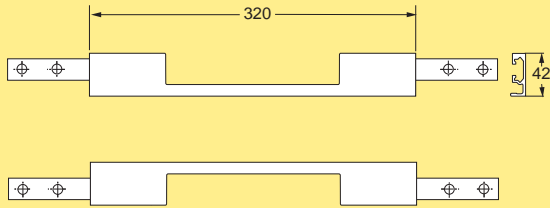

Guide rail kit for locating station **3927386**  
One pair, including connecting strips

**Guide rail kit with drip catcher for locating station**

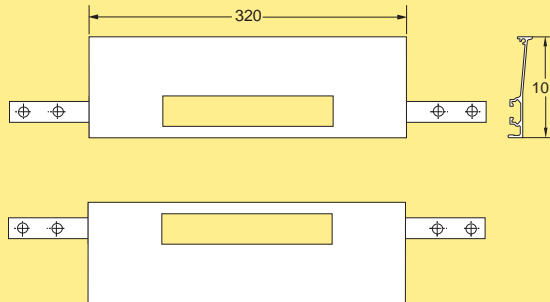

Guide rail kit for locating station  
With integrated drip catcher **3927387**  
One pair, including connecting strips

*About proximity switches*

The proximity switch (not supplied by FlexLink) must have a minimum effective sensing distance of 3,5 mm to the steel initiator plate.

Example: the effective sensing distance for SICK (IM12 sensing range 6 mm) is 4,86 mm. This is calculated as follows:  $6 \text{ mm} \times 0,81^* = 4,86 \text{ mm}$ .

\*Useful sensing range =  $0,81 \times$  nominal sensing range.

**Bracket for horizontal proximity switch**

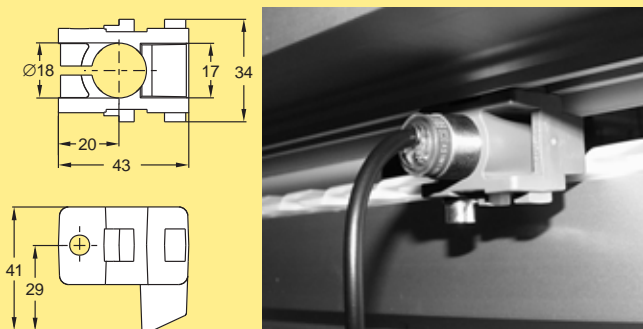

Bracket for horizontal proximity switch Ø18 mm **XKPB 18 H**  
Acetal resin. Including screw, T-slot nut and washer

**Pneumatic stop for pallet locating station**

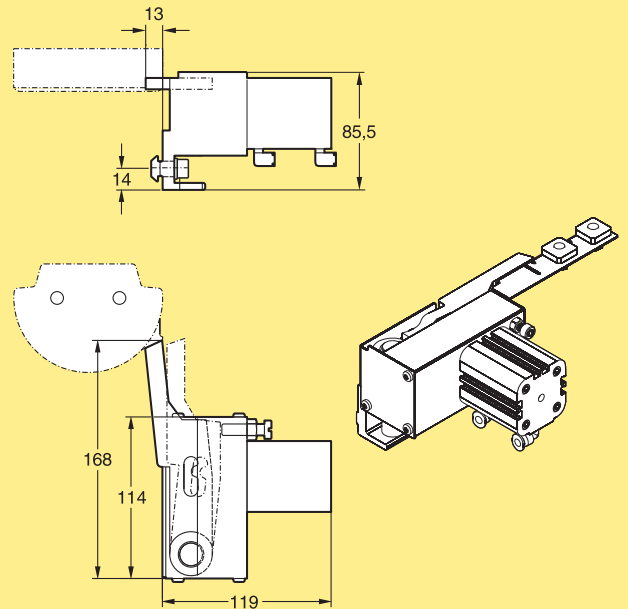

Pneumatic stop for pallet locating station, double-actuated **XKPD 32x15 LB**

*Housing: anodized aluminium. Cover: stainless steel. For use with cylinder position sensor. Including Ø6 pipe connections and the necessary mounting hardware.*

*The stop is double-acting, but also includes an integrated spring for stop out if air supply is cut off.*

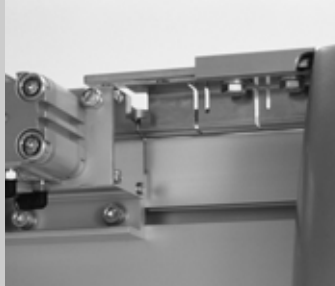

*The stop device comes with a cover for the stop lever. The cover dimensions are for use with the largest pallet. It can easily be cut for use with the other standard pallet sizes. The cover is fastened to the T-slot of the guide rail.*

*Note. Designed for use with chain XKTP 5 A. Chain XKTP 5 cannot be used for XK pallet handling.*

## Pallet stop device

### Pneumatic stop

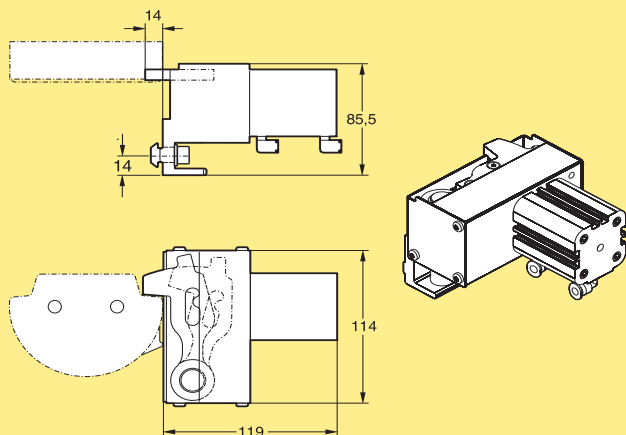

Pneumatic stop device  
Double-actuated

**XKPD 32×15 B**

*Housing: anodized aluminium. Cover: stainless steel. For use with cylinder position sensor. Including  $\varnothing 6$  pipe connections and the necessary mounting hardware. The stop is double-acting, but also includes an integrated spring for stop out if air supply is cut off. Connection: G 1/8". Stroke: 15 mm. Locating accuracy:  $\pm 1$  mm.*

*Note. Designed for use with chain XKTP 5 A. Chain XKTP 5 cannot be used for XK pallet handling.*

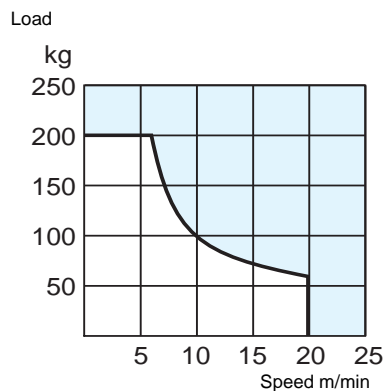

*The diagram shows the maximum permissible weight of a group of pallets (product weight + pallet weight) that the stop device is capable of stopping, as a function of the conveyor speed.*

### Proximity switches

See page 225



**Divert modules**

Divert modules are used to guide selected pallets from one conveyor to another.

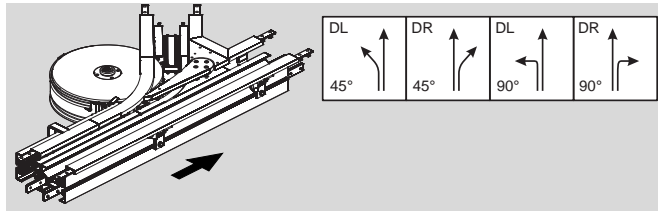

**Merge modules**

Merge devices are used to guide pallets back from a satellite conveyor into the main conveyor (highway).

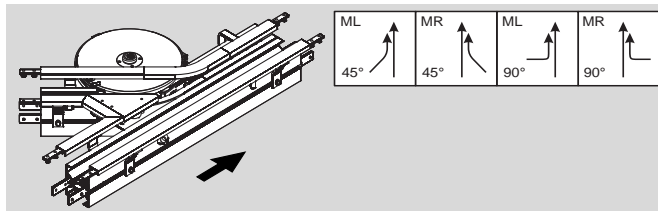

**Divert and Merge modules**

A combined divert/merge device is used to guide selected pallets from a main conveyor (highway) into a satellite conveyor and back. The combination also permits recirculating the pallets on the satellite until the pallet is ready to return to the highway.

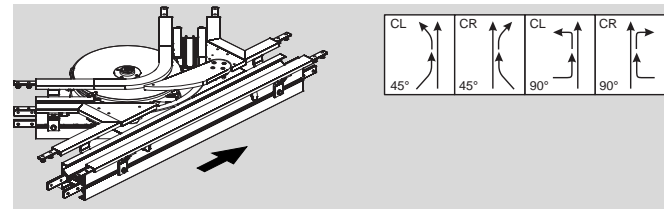

**Configurator tool**

The divert/merge/combination modules can be individually configured to the right pallet size using the configurator tool. The configurator tool will create a geometrically correct 3D CAD-model that can be inserted in the layout. The configured module will include the function, stops, conveyor beams, wheel bends and guide rails.

Configurable options include:

- Specific pallet size
- Sensors
- RFID readers and brackets
- Photo eyes and brackets

PO  
X45  
XS  
XL  
XLP  
X85  
X85P  
XH  
XK  
XKP  
X180  
X300  
GR  
CS  
XT  
WL  
XC  
XF  
XD  
XLX  
X85X  
X180X  
X300X  
GRX  
CSX  
ELV  
CTL  
FST  
TR  
APX  
IDX

## Divert modules

### Divert module 45°

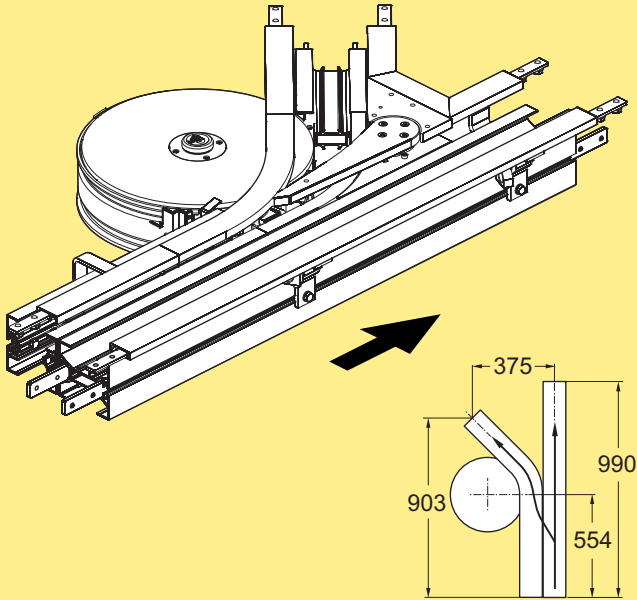

#### Divert module 45° \* **XKUT 45 D**

Figure shows type L (divert to left)  
 \* Use online configurator when ordering  
 Effective track length: 2,02 m 1-way (4,04 m 2-way)

### Divert module 90°

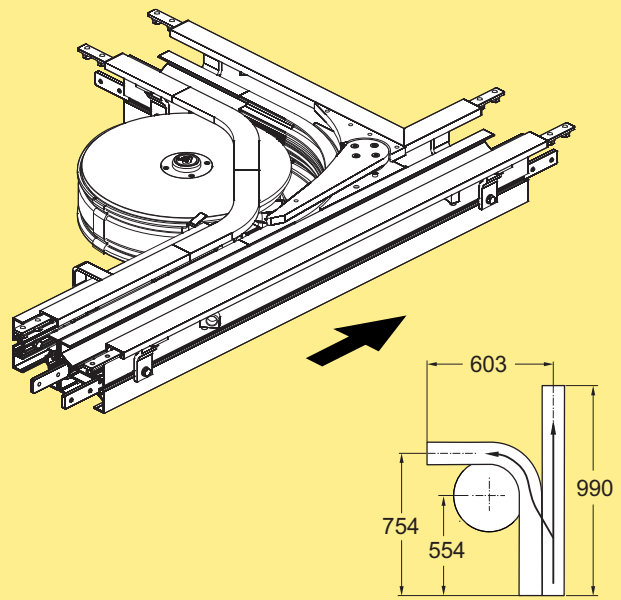

#### Divert module 90° \* **XKUT 90 D**

Figure shows type L (divert to left)  
 \* Use online configurator when ordering  
 Effective track length: 2,2 m 1-way (4,4 m 2-way)

## Merge modules

### Merge module 45°

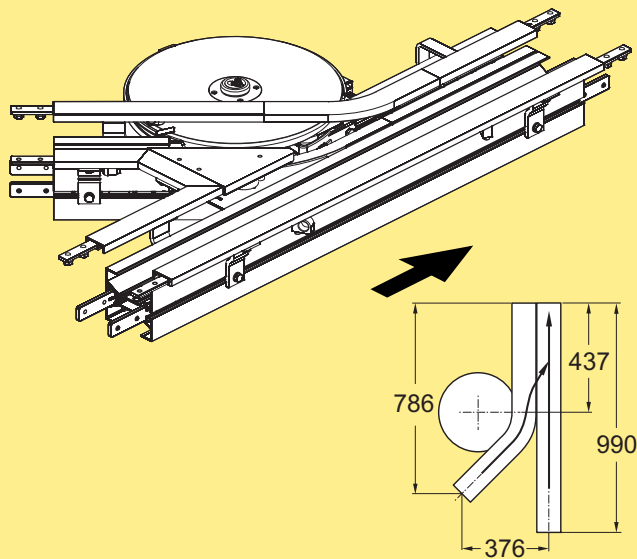

#### Merge module 45° \* **XKUT 45 M**

Figure shows type L (merge from left)  
 \* Use online configurator when ordering  
 Effective track length: 2,02 m 1-way (4,04 m 2-way)

### Merge module 90°

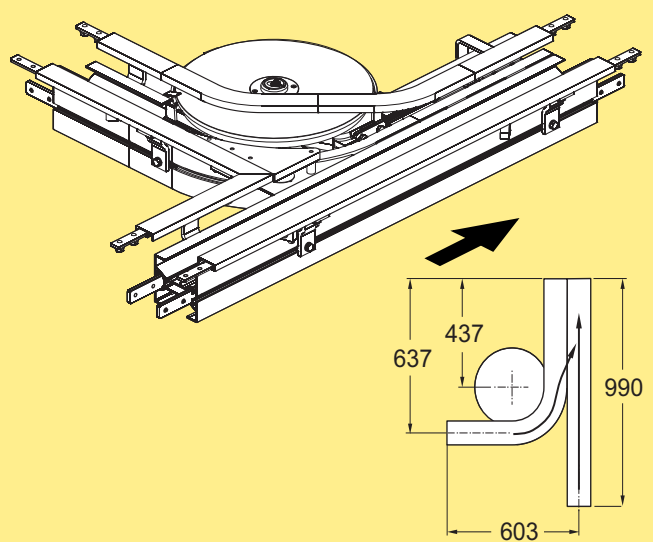

#### Merge module 90° \* **XKUT 90 M**

Figure shows type L (merge from left)  
 \* Use online configurator when ordering  
 Effective track length: 2,2 m 1-way (4,4 m 2-way)

- PO
- X45
- XS
- XL
- XLP
- X85
- X85P
- XH
- XK
- XKP**
- X180
- X300
- GR
- CS
- XT
- WL
- XC
- XF
- XD
- XLX
- X85X
- X180X
- X300X
- GRX
- CSX
- ELV
- CTL
- FST
- TR
- APX
- IDX

**Divert and merge module 45°**

Divert and merge module 45° \* **XKUT 45 C**  
 Figure shows type L (divert to left, merge from left)  
 \* Use online configurator when ordering  
 Effective track length: 1,94 m 1-way (3,9 m 2-way)

**Divert and merge module 90°**

Divert and merge module 90° \* **XKUT 90 C**  
 Figure shows type L (divert to left, merge from left)  
 \* Use online configurator when ordering  
 Effective track length: 2,0 m 1-way (4,0 m 2-way)

