



## XT Compact conveyor

### Contents

XT Compact conveyor	
XTUC S11 .....	2

### Revision list

Doc ID	Date	Type of revision	Entered by
XT013-E3	2008-09-15		JE
XT013-E4	2009-03-18		JE



# XT Compact conveyor

## XTUC S11

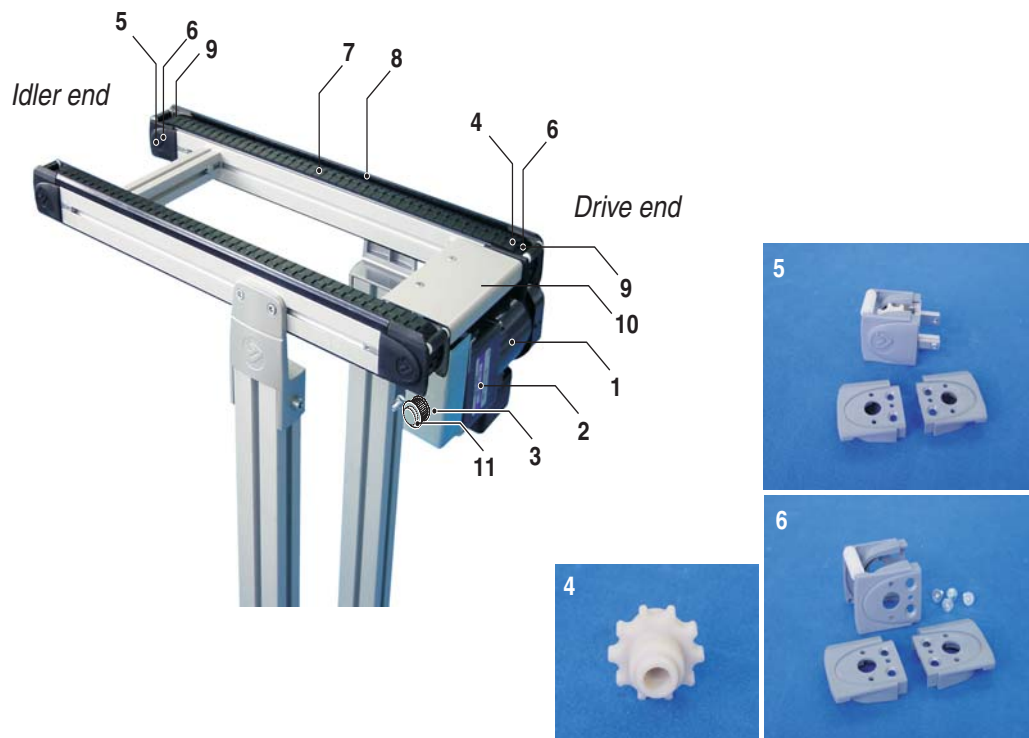

Item	Description	Part No	Qty	Comments	Type
1	AC motor 60 W 50 Hz	5111731 (S9I60GXH-TCE)	1	SPG. Including capacitor 3,5 µF	1
	AC motor 60 W 60 Hz	5111732 (S9I60GEH-TCE)	1	SPG. Including capacitor 12,0 µF	1
2	Gearbox	See Table A below	1		1
3	Tooth belt	5111743	1	250-5MGT3-15	1
4	Drive wheel	5055848	1		1
5*	Idler end, standard	5055847	1		1
	Idler end, conductive	5055846	1		1
6**	Idler end kit, standard	5055844	1	Fits both drive and idler end	1
	Idler end kit, conductive	5055845	1	Fits both drive and idler end	1
7	Plain chain	5045028	2	3 m	1
	Plain chain, conductive	5051585	2	3 m	1
8	Slide rail	XTCR 25 H		AS0. Length 25 m	1
	Slide rail	XTCR 25 E		AS2. Length 25 m	1
	Slide/guide rail	XTCR 3 HB		AS0. Length 3 m	1
	Slide/guide rail	XTCR 3 EB		AS2. Length 3 m	1
9	Ball bearing	61801-2Z	6	Fits both drive and idler end	3
10	Shaft drive end	5995033_PW	1	Needs PW or c/c	2
11	Belt wheel	5111745	1	20-5-MR-15 (D=12 mm)	1
* Item 5 includes idler end (1), left guide (1) and right guide (1).				Figures "1", "2", and "3" in the "Type" column represent:	
** Item 6 includes side plate without guide (2), left guide (1), right guide (1), roller kit (1) and screws (4).				1. Spare parts kits, immediately available for ordering	
				2. RFQ items (request for quote)	
				3. Standard hardware items, normally purchased locally	

**Table A**

Speed	50/60 Hz	Motor Part No	Gearbox Part No	Comments
V05	50 Hz	5111731	5111742	S9KC40BH
V10	50 Hz		5111741	S9KC20BH
V15	50 Hz		5111740	S9KC12,5BH
V20	50 Hz		5111739	S9KC10BH
V06	60 Hz		5111732	5111742
V12	60 Hz		5111741	S9KC20BH
V18	60 Hz		5111740	S9KC12,5BH