

Conveyor system X45

User Documentation

Conveyor system X45

User Documentation

© Flexlink AB 2010

All Rights Reserved

No part of this program and manual may be used, reproduced, stored or transmitted in any form or by any means without the written permission of FlexLink Components AB. The contents of this manual are for informational use only. All information and specifications contained in this document have been carefully checked to the best efforts of FlexLink Components AB, and are believed to be true and accurate as of time of publishing. However, due to continued efforts in product development FlexLink Components AB reserves the right to modify products and its manuals without notice.

FlexLink Components AB assumes no responsibility or liability on any errors or inaccuracies in this program or documentation. Any kind of material damages or other indirect consequences resulting from any FlexLink Components AB's product part, documentation discrepancies and errors or non-anticipated program behavior are limited to the value of appropriate products purchased from FlexLink Components AB. The products are delivered to the customer at the 'as is' state and revision level they are on the moment of purchasing, and are declared in detail in the license agreements between FlexLink Components AB and user. User accepts and is obliged to follow the guidelines stated in the separate license agreement needed in using any parts of this product package.

	Preface	1
1	Safety	3
1.1	System information	3
1.2	The most important safety conditions	4
1.3	Description of safety provisions	6
1.4	Safety measures to be taken	8
2	Technical specification	9
2.1	Technical characteristics X45	9
2.2	Operating conditions	10
3	Functions	11
3.1	Motors	11
3.2	Diverter, Mergers, Combined Diverter/Mergers, Transfers, Stop and Locating unit for Puck handling	12
3.3	Maximum permissible weight	18
4	Unload the X45 system	20
4.1	Preparation	20
4.2	Unloading instructions	21
5	Mounting, installation, adjustment	22
5.1	Provisions to be provided	22
5.2	Mounting chain to X45 conveyor modules – Idler end	23

5.3	Assembly of modules	25
5.4	Adjustment	32
6	Technical maintenance	33
6.1	Maintenance intervals	33
7	Recommended spare parts	34
8	Supplier's information	35

Preface

Purpose of this manual

The purpose of this manual is to describe a number of operations that are intended for the user concerned. Here it becomes clear how the user can work as well and as safely as possible. By making use of clear illustrations and texts FlexLink wants to achieve a simple and safe way of working with the X45 system. This document contains remarks that point out a risky or specific situation to the user. In many cases this situation is provided with one of the symbols given below.



General warning for danger!



Warning for electrical voltage!



Attention, this is an important notice!

Compliance with the operations described in this document is important in order to prevent dangerous situations and unnecessary damage to the X45 system. Carefully keep this document! It is recommended to keep one copy near the conveyor system and one copy with your technical documentation.

Structure of the manual

The user's manual has been composed in such a way, that a number of operations can quickly and easily be found. This manual will not describe operations that are not meant for the user. It does, however, indicate what the user must do when carrying out a certain operation, for example calling in technical staff. FlexLink would like to point out to the user that section 1 Safety is to be read carefully.

Requirements of the user

The X45 Conveyor system must be operated by any adult person who has become acquainted with section 1 Safety. If the user is not technically qualified, he or she may not carry out any maintenance or repair activities on the system.



Note! *Maintenance activities on the system may only be carried out by a technically qualified person.*



NB: *Technically qualified employees means: employees that have followed an adequate training for carrying out the activities involved and have a good ability to read and understand the English language.*

1 Safety

The X45 conveyor system has been designed in such a way, that it can be used and maintained in a safe way. This holds for the application, the circumstances and the instructions described in the manual. Any person working with or on this system should study the manual and follow the instructions. It is the responsibility of the employer to make sure that the employee is familiar with and follows these instructions.

The company or the country in which the system is used may require extra safety measures. This particularly applies to the working conditions. This manual does not describe how these are to be complied with. In case of doubt, consult your government or safety officer!

1.1 System information

The project number and/or general drawing number shall always be specified when communicating with FlexLink with respect to the module.

Project number	See module nameplate
Supplier	FlexLink Systems Polska Sp z o.o.o
Module type:	Module
Date of manufacture	See module nameplate
Identification. no.	See module nameplate

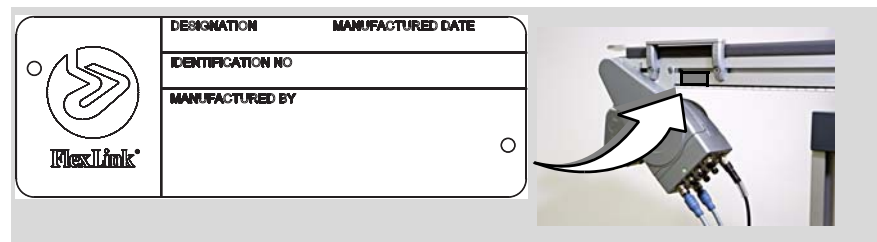

Figure 1 Module nameplate

The modules nameplate is located on the module near the electrical motor for the drive unit.

1.2 The most important safety conditions

At the moment that the X45 system is going to be operated by a user, the following safety conditions must be met:

- Only persons who have read and understood the operating instructions are allowed to operate, maintain and clean the system.
- Provide good ambient lighting to enable the operator to work well and orderly with the system.

1.2.1 General



- Incorrect use of the equipment can cause personal injury.
- Do not wear clothing or other articles that can fasten.
- Follow the instructions in this user manual when transporting the machine. FlexLink Components AB must approve all modifications or changes to this system.
- Only use recommended spare parts.
- Only authorised personnel may open electrical units.
- FlexLink is not responsible for damage if service on the equipment is not performed in accordance with this user manual.

1.2.2 Service technicians



Service technicians must have:

- Sufficient knowledge for reading technical information
- Ability to comprehend technical drawings
- Basic knowledge of mechanics
- Sufficient knowledge in the use of hand tools



1.2.3 Electricians

Electricians must have:

- Experience from similar installations
- Sufficient knowledge to work from drawings and wiring diagrams
- Knowledge of local safety regulations for electrical power and automation

To avoid risks, only experienced personnel with technical knowledge and experience may perform repair work on the electronics components.



1.2.4 Operators

To correctly use the equipment, operators must have appropriate training and/or experience.

1.3 Description of safety provisions

Before putting the system into operation some safety provisions are to be taken care of. The purpose of these safety provisions is to protect the user, the product and the system against undesired situations (damage). Without these safety provisions FlexLink cannot give a guarantee on any damage caused in absence of these safety provisions.

The table below gives a general description of the safety provisions required. Here it should be noted that only technically qualified employees are allowed to work on the settings of the safety provisions!

Control	Remark
Emergency stop switch	<p>It is recommended that the X45 conveyor system should be provided with one or more emergency stop switches that can be operated within reach of the user.</p> <p>The switch must have the standard red colour.</p>
Motor protection	<p>Should the motor be overloaded for certain reasons, this should be detected. Without this protection there is a chance that the Motor or other components of the X45 system will be damaged.</p>



1.3.1 Noise level



The noise level produced by the X45 conveyor system is under 65 dB(A).

1.3.2 Electrical cabinet



Ensure that the electrical cabinet is closed and locked after working in the electrical cabinet.

Never bypass the safety system.

Before working in the electrical cabinet, the main switch to the motor must be turned off and locked. The key is retained by the service technician until work is finished.

Examples of service work include:

- Disconnection of wiring
- Replacement of motors, etc.
- Service work in the electrical cabinet, terminal boxes, etc.
- Service work performed on the machine that cannot be seen from the electrical cabinet.

For adjustment of photo-electric cells, inductive sensors, etc., power is required:

- Stop the system and wait until the moving parts have come to a complete stop.

1.4 Safety measures to be taken

For a safe operation of the conveyor system a number of safety measures are to be taken. These include the following measures:

- **Clean floor surface** - With a clean floor surface the operator will not be hindered while operating the system. This can prevent tripping or slipping, so that the operator does not unexpectedly come into contact with the system.

2 Technical specification

2.1 Technical characteristics X45

Beam width	45 mm
Chain width	43 mm
Chain pitch	12,7 mm
Drive unit capacity	100- 200 N
Chain tension limit	100-200 N
Item width	10-100 mm
Maximum conveyor length	6 m
Maximum weight on conveyor	30 kg
Maximum load per 100 mm conveyor length (see figure below)	800 g (100 g/ link)
Maximum single item weight, horizontal transport (see figure below)	800 g
Conveyor speed	5-20 m/min
Horizontal bends:	30°/45°/90°/180°
Radius 150 mm	
Note! Maximum 2 bends/conveyor	
Vertical bends:	5°/15°
Radius 400 mm	
Note! 2 bends/conveyor	
Electrostatic discharge feature (ESD)	Standard/conductive

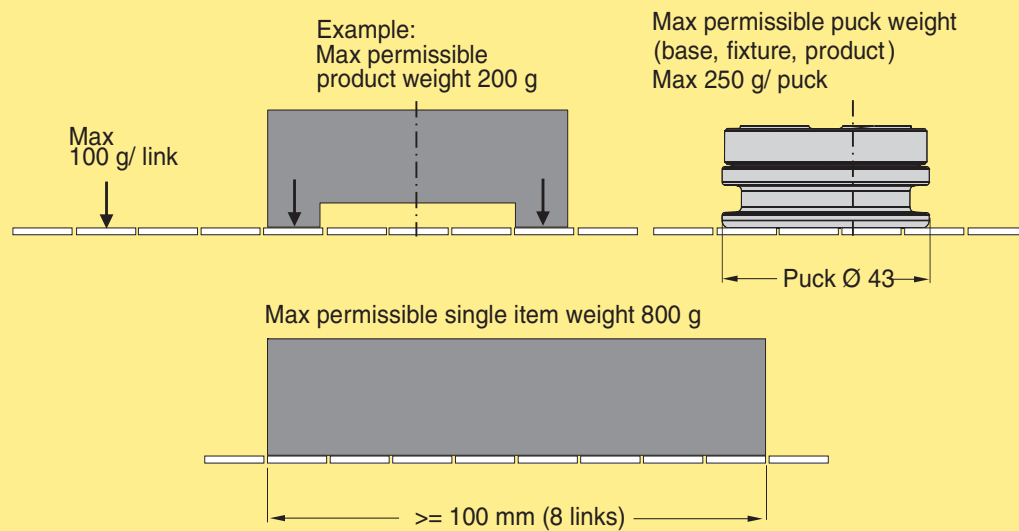

2.2 Operating conditions

The circumstances under which the X45 conveyor system can be applied partly depend on the materials selected. FlexLink has defined a number of parameters within which the system would be allowed to function. Should the system still be applied beyond these limiting values, FlexLink cannot guarantee the good functioning of it.

Ambient temperature (in operation)	-20° to +60°C
During transport / storage	5 to +40°C
Relative air humidity (RH)	10% to 95%, not condensing
Lighting	Normal ambient lighting

3 Functions

3.1 Motors

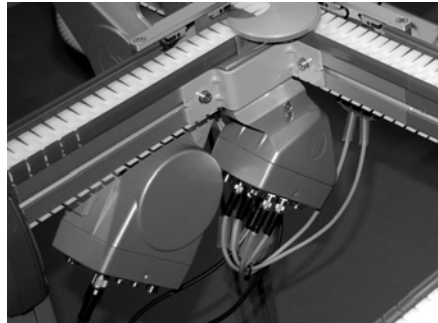

The control system of the platform X45e is structured in an object oriented way. All motors in the platform have embedded control units and local sensors are connected directly to each motor unit. This layout gives a big advantage regarding software developing, electrical design and electrical installation.

3.1.1 Function control

The motor unit consists of a motor, circuit boards and eight connectors in an encapsulated housing. There are two types of motor units, the drive unit and the function unit. All that differs on these variants are the motor and the mechanical housing.

The drive unit has a permanent magnetic (PM) motor and the function unit has a stepper motor with an analogue position feedback sensor. An embedded microprocessor is dedicated for the application control. Local sensors are connected directly to this unit.

The motors can be autonomously controlled only by the input of the local sensors or controlled from a line controller over a CANopen network.

The motor unit has also a LED on each side indicating its status. If the motors are in autonomous mode they only need power (24VDC) to work properly.

3.1.2 Line control

If a line controller is used up to 127 motors can be interlinked via an external CANopen network. RFID reader/writers can be connected to the line controller via a separate network (Profibus, DeviceNet or Ethernet). All dynamic route handling has to be implemented in the line controller.

The main electrical cabinet supplies the motor units with power, 24 VDC. The power is divided in safe and continuous power in order to have the possibilities to implement emergency or safety stops

3.2 Diverters, Mergers, Combined Diverter/ Mergers, Transfers, Stop and Locating unit for Puck handling



3.2.1 Diverters

Diverters are used to split a flow of pucks from one line into two. The lines can be parallel or in a 90° angle.

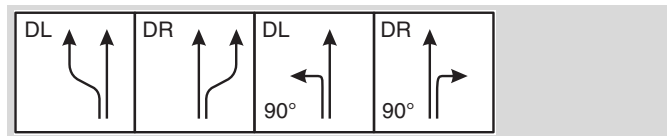

The diverter is an active unit with one infeed and two outfeed conveyors.

There are four different variants of the diverter.

- Diverter, Parallel, Left
- Diverter, Parallel, Right
- Diverter, 90°, Left
- Diverter, 90°, Right

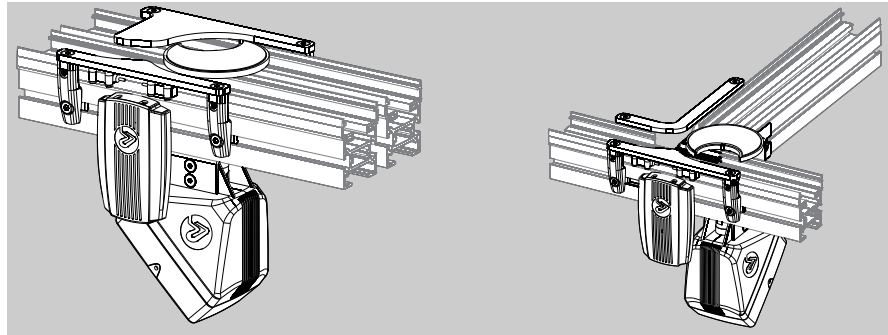

Figure 2 Diverter, parallel and 90°

The unit has two positions for photoelectric sensors. The first one is used for sensing the queue status of the infeed conveyor. This sensor can be replaced by a RFID read/write head.

When a puck arrives the rotation disc opens up to receive the puck. The second sensor is used for detecting that the puck has reached the gap of the rotation disc. This is the trigger signal for the main rotation of the rotation disc, with a puck in the gap.

The decision of which outfeed conveyor to release the puck on can be received from the external bus, via a local sensor or from a predetermined pattern.

3.2.2 Mergers

Mergers are used to combine the flow from two lines into one. The lines can be parallel or in a 90° angle.

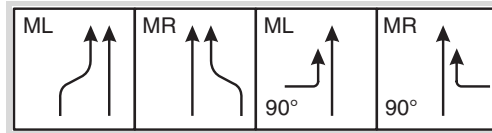

The merger is an active unit with two infeed and one outfeed conveyor.

There are four different variants of the merger.

- Merger, Parallel, Left
- Merger, Parallel, Right
- Merger, 90°, Left
- Merger, 90°, Right

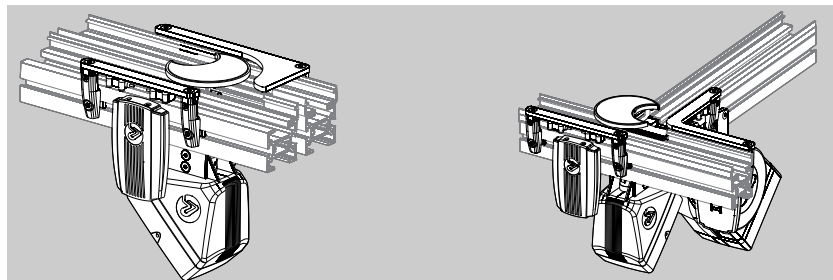

Figure 3 Merger parallel and 90°

The unit has two sets of guide brackets each containing two photoelectric sensors. The first sensor position on each side is used for sensing the queue status of the infeed conveyors. These queue sensors are the trigger signal for the merger to moving the rotation disc to one of the two receive positions. This is done either clockwise or counter clockwise depending on which conveyor to receive pucks from.

The last sensor is used for sensing pucks in the gap of the rotation disc. This is the trigger signal for the main rotation of the rotation disc, with a puck in the gap. When the rotation disc has reached the release position the cycle is complete and the unit waits for a new puck to arrive.

3.2.3 Combined Diverter/mergers

A combined diverter/merger are used to create a sub line for example to guide pucks out and in on a satellite conveyor from the main conveyor. They can also be used as "shortcuts".

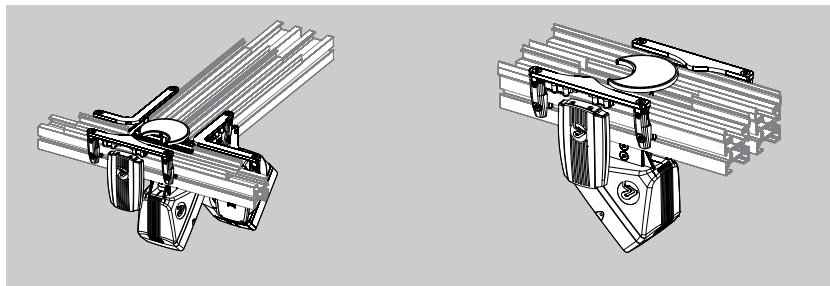
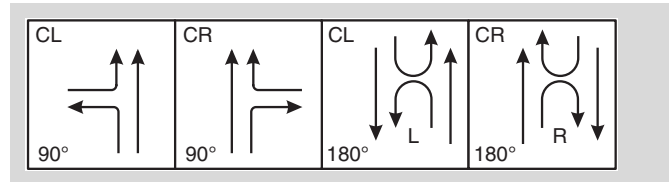
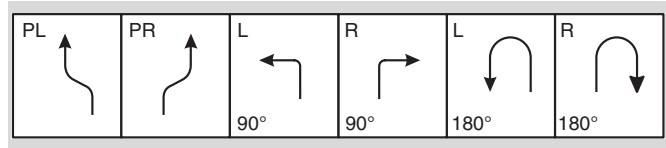

Figure 4 Combined Diverter/Merger 90° and 180°

This function has the behaviour from both the diverter and the merger. The prioritized order can be predetermined or decided dynamically from a line controller.

3.2.4 Transfers

Transfers are used to transfer the puck between the conveyors in a system. The parallel transfers are passive but the 90° and 180° angled transfers are driven by a motor.



There are six different variants of the transfers.

- Transfer, Parallel, Left
- Transfer, Parallel, Right
- Transfer, 90°, Left
- Transfer, 90°, Right
- Transfer, 180°, Left
- Transfer, 180°, Right

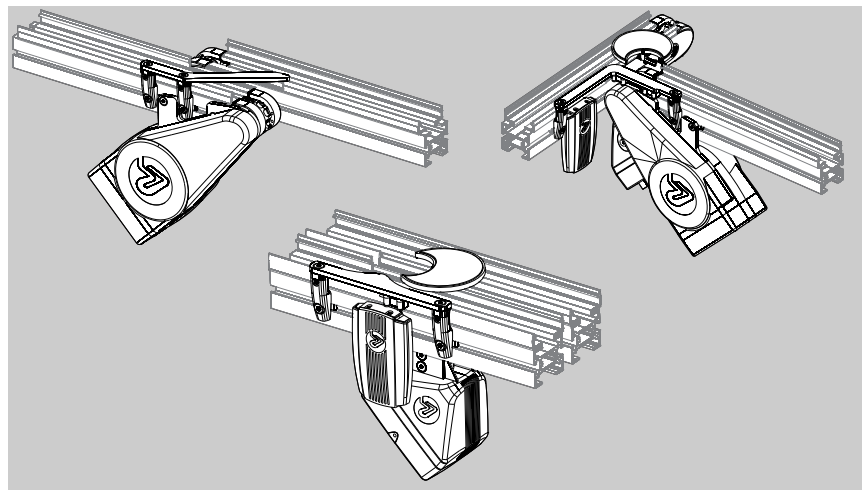

Figure 5 Transfer, parallel, 90° and 180°

3.2.5 Stop

The stop unit is an active unit acting on a single conveyor.

The unit has only one photoelectric sensor. This detects a puck in the queue. The default position of the stop unit is closed, i.e. it is able to resist a queue of puck. If the stop is deactivated the unit opens up to receive a puck.

Directly after the unit has opened up it closes and releases the received puck. This unit can be controlled either via the external bus or in local mode by a signal in the local digital input.

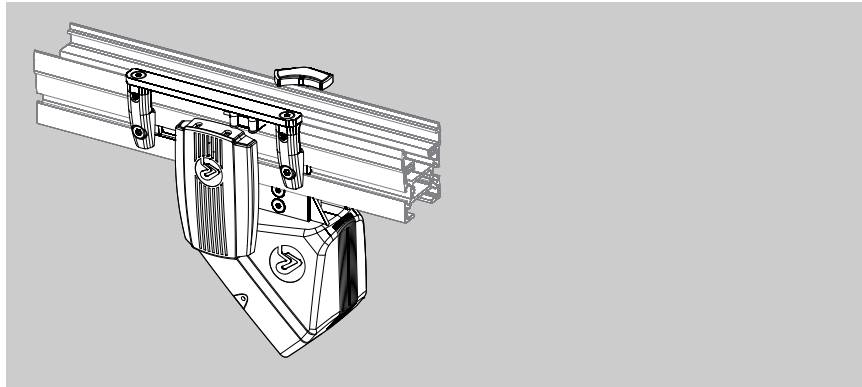

Figure 6 Stop unit

3.2.6 Locating station

The locating Station is an active unit acting on a single conveyor.

The station has only one photoelectric sensor. This is detecting that the puck has reached the gap of the rotation disc. The locating station can also be equipped with a RFID read/write head on the locating position. The station can be controlled either via the external bus or using only local control.

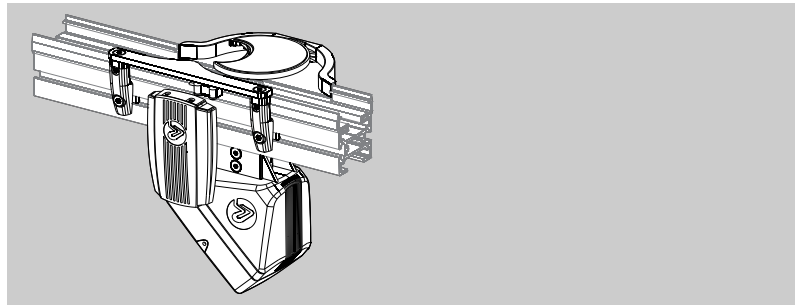
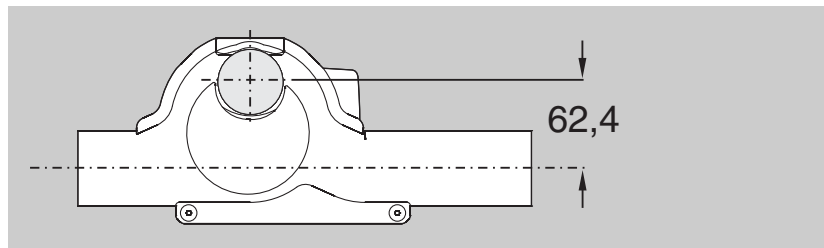

Figure 7 Locating unit



The rotating disc guides the puck sideways out of the conveyor into the locating position. A spring function included in the rotating disc presses the puck towards a v-shaped block. In this position the puck is locked vertical and can take limited vertical forces e.g. unload or load a test tube. No loads are aloud in the X, Y-plane. Locating accuracy is $\pm 0,2$ mm.

3.3 Maximum permissible weight

Maximum permissible weight

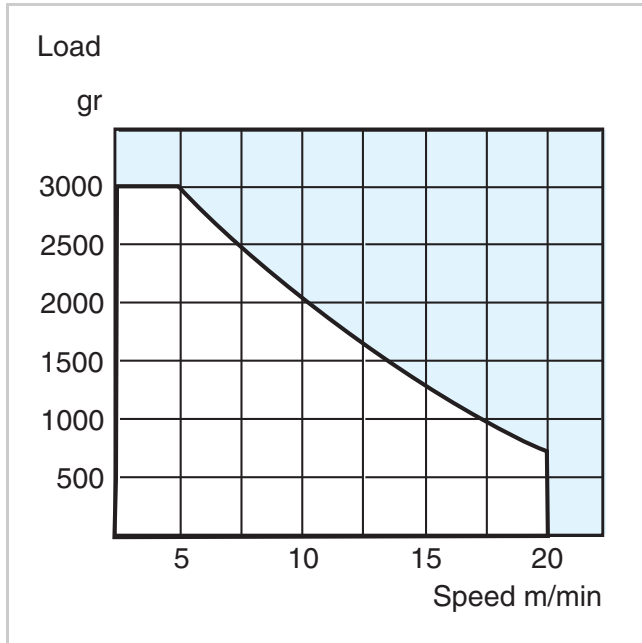

The diagram shows the maximum permissible weight of a group of pucks (product weight + puck weight) that the functions Divert, Merger, Combined Diverter/Merger, Stop and Locating station are capable stopping, as a function of the conveyor speed.

4 Unload the X45 system

4.1 Preparation

This section describes the steps that are required for unloading the modules for the X45 system.

Note! *The operations concerned are to be carried out calmly in order to be able to carefully monitor any movement of the X45 module.*

Before starting the unloading a good preparation is required. The appropriate devices must be available. Apart from that the first transport check is an important part of the unloading, as in case of damage this should be mentioned on the delivery note in relation to guarantee and the like.

The first transport check after arrival of the modules a transport check is to be carried out. The check can be carried out at the moment the module has been unloaded from the container or the truck. The technical specification gives the dimensions to be checked. Is the module delivered undamaged and is it the correct module?

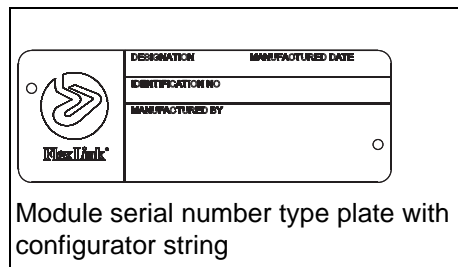

Note! *Any damage is to be mentioned on the delivery note and should immediately be reported to the supplier. This with respect to the guarantee of the module.*

4.2 Unloading instructions

Before starting unloading, all fastening means (securing belts, screws, etc.) that secure the module unto the means of transport must be removed. Subsequently check whether the transport supports are still connected well to the module. After this the unloading procedure may be started.

4.2.1 Shipment

Modules are normally delivered in flat boxes with a maximum length of approximately 3 m. See photo below. Conveyor modules will be delivered in sections of maximum 3 m which are easy to reassemble.

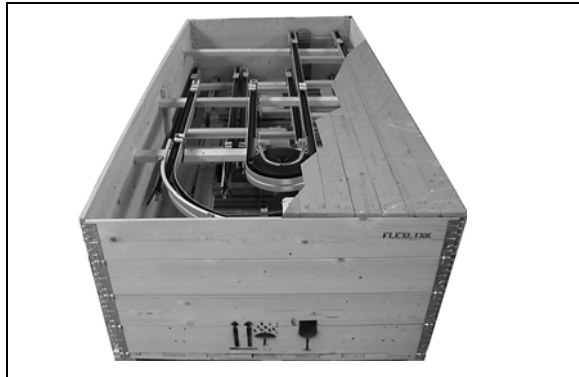

5 Mounting, installation, adjustment

This section deals with the operations to have the modules function well within a (transport) system.

Longer conveyor modules (approx >3m) are delivered in sections. The sections are marked up and can easily be joined together. Also the corresponding conveyor chain is marked up and has to be assembled according to section 5.2.

5.1 Provisions to be provided

Make sure before assembly that the surroundings are clean and free from obstacles and the mounting surface is clean and level. Besides, it should be repeated that the operations are to be carried out in a calm and controlled way!

After having placed the modules in the correct position, the modules is to be fastened to the mounting surface by using the holes in the adjusting feet.

5.2 Mounting chain to X45 conveyor modules – Idler end

5.2.1 Tools

Allen key	3 mm
Pin insertion tool	
Screwdriver	

5.2.2 Procedure

- 1 Use the screwdriver to remove the plastic cap on the idler end. Loosen the screws on both side on the basic unit, use a 3 mm Allen key.



- 2 Remove the sideplates, use a screwdriver.



- 3 Feed the chains into the conveyor until they reach the drive wheel at the driving end.

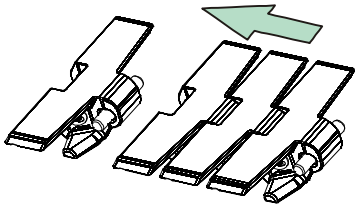

CAUTION! Check the feed direction of the chain

- 4 Make sure that the pin snaps in to the correct position (centered).

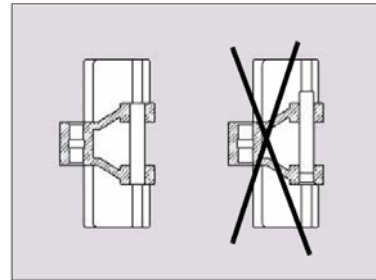

- 5 Feed the chains to the drive wheel and turn the drive shaft until the chains are hanging a bit below the conveyor.

- 6 Continue and feed the return chain

CAUTION! Make sure that the chain enters the drive wheel correctly.

- 7 Use a pair of slip joint pliers to insert the pin halfway into the chain link.

- 8 Join the chain ends.

- 9 Press the pin through the chain. Use the pin insertion tool.

TIP! Use a clamp (A) to keep the chain stretched.



5.3 Assembly of modules

The modules are to be assembled according to the system layout.

Find the correct position for connecting modules using the measurements in section 5.3.2 on page 27 to section 5.3.7 on page 31

When assemble the parallel conveyors use the beam spacer XUCD 15x20 (see figure below). The distance between the spacers is to be approximately no more than 600 mm

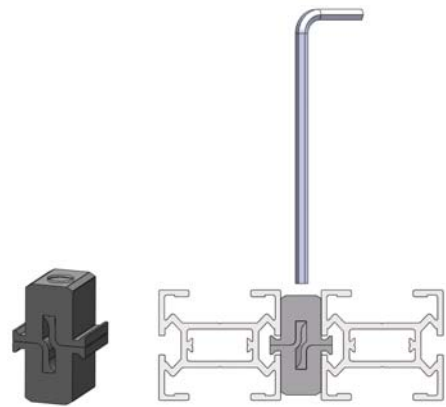

Note that it is very important that the modules lines up horizontal according to figure below.

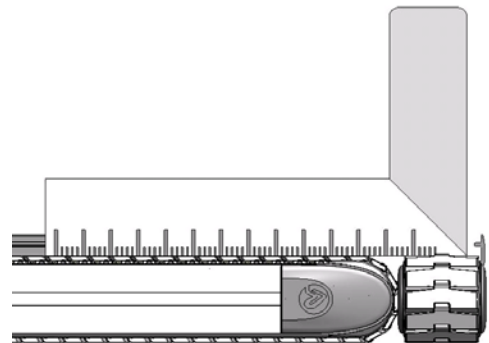

5.3.1 Wiring

The functions motors are to be connected according to figure below and mounting instructions section 5.3.2 on page 27 to section 5.3.7 on page 31.

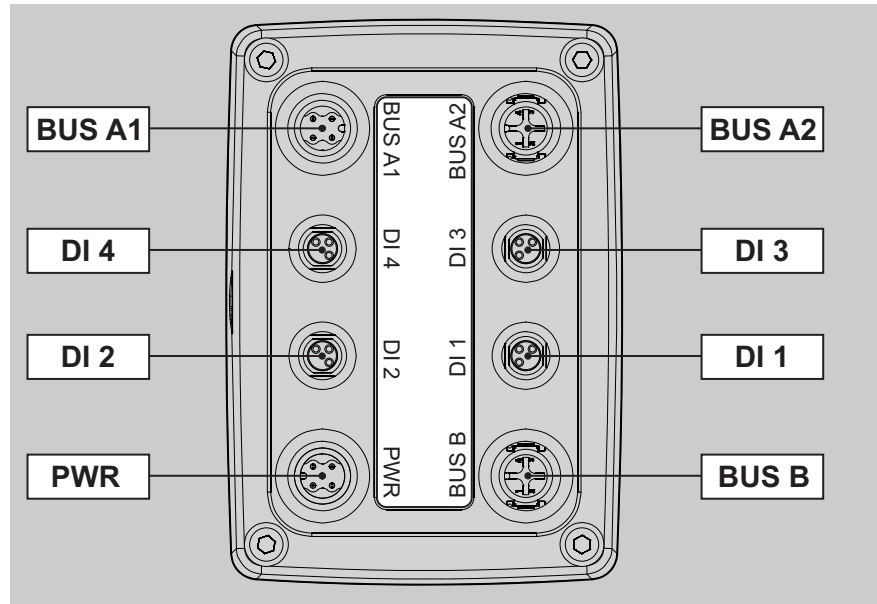

The following schematic presentation shows how the various modules are combined to form a complete X45 conveyor system, mechanical installation as well as the electrical interface are showed.

Markings on plate	Explanation	
PWR	Power in	Connect power cable
BUS B	Internal bus	Used for parameter settings
DI 1	Digital input 1	Sensor, connect if used, see section 5.3.2 on page 27 to section 5.3.7 on page 31
DI 2	Digital input 2	Sensor, connect if used, see section 5.3.2 on page 27 to section 5.3.7 on page 31
DI 3	Digital input 3	Sensor, connect if used, see section 5.3.2 on page 27 to section 5.3.7 on page 31
DI 4	Digital input 4	Sensor, connect if used, see section 5.3.2 on page 27 to section 5.3.7 on page 31
BUS A1	External bus in	Connect this if external CANOpen network is used
BUS A2	External bus out	Connect this if external CANOpen network is used

5.3.2 Mounting instruction, Diverter

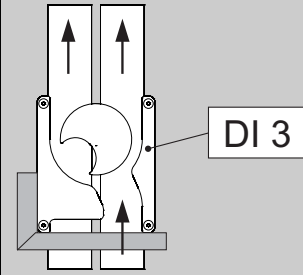
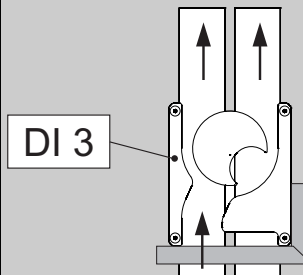
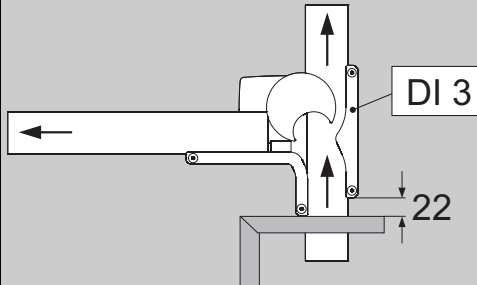
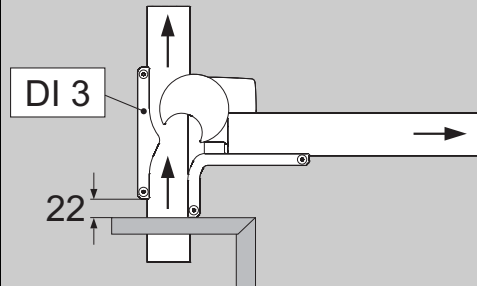
Function	Direction	Designation	Assembly mechanical/electrical	Item 1,2
Divert	Parallel	Left		(XUUT DL 1)
				(XUUT DL 2)
		Right		(XUUT DR 1)
				(XUUT DR 2)
	90°	Left		(XUUT 90 DL 1)
				(XUUT 90 DL 2)
		Right		(XUUT 90 DR 1)
				(XUUT 90 DR 2)

5.3.3 Mounting instruction, Merger

Function		Direction	Designation	Assembly mechanical/electrical	Item 1,2
Merge	Parallel	Left	XUUT ML		(XUUT ML 1)
					(XUUT ML 2)
		Right	XUUT MR		(XUUT MR 1)
					(XUUT MR 2)
	90°	Left	XUUT 90 ML		(XUUT 90 ML 1)
					(XUUT 90 ML 2)
		Right	XUUT 90 MR		(XUUT 90 MR 1)
					(XUUT 90 MR 2)

5.3.4 Mounting instructions, Combined Diverter/Merger

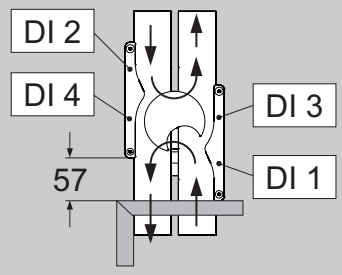
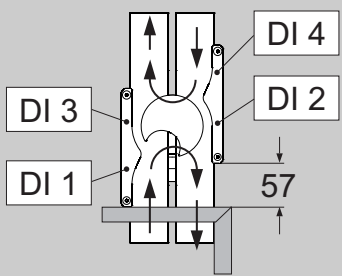
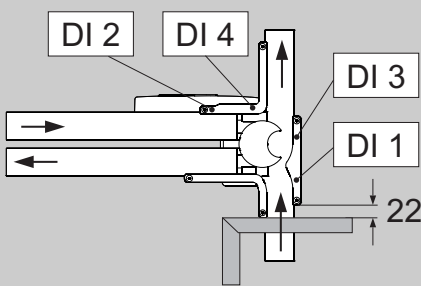
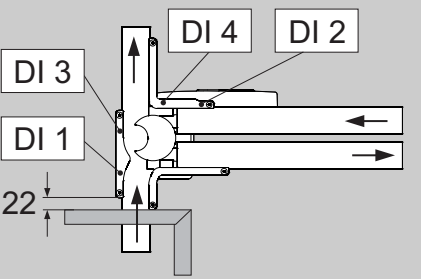
Function	Direction	Designation	Assembly mechanical/electrical	Item 1,2 and 3
Combined Diverter/Merger	Parallel	Left		(XUUT 180 CL 1)
				(XUUT 180 CL 2)
		Right		(XUUT 180 CR 1)
				(XUUT 180 CR 2)
	90°	Left		(XUUT 90 CL 1)
				(XUUT 90 CL 2)
				(XUUT 90 CL 3)
		Right		(XUUT 90 CR 1)
				(XUUT 90 CR 2)
				(XUUT 90 CR 3)

5.3.5 Mounting instructions, Transfer

Function	Direction	Designation	Assembly mechanical/electrical	Item 1,2
Transfer	Parallel	Left		(XUUT PL 1)
				(XUUT PL 2)
		Right		(XUUT PR 1)
				(XUUT PR 2)
	90*	Left		(XUUT 90 L 1)
				(XUUT 90 L 2)
		Right		(XUUT 90 R 1)
				(XUUT 90 R 2)
	180*	Left		(XUUT 180 L 1)
				(XUUT 180 L 2)
		Right		(XUUT 180 R 1)
				(XUUT 180 R 2)

5.3.6 Mounting instructions, Stop

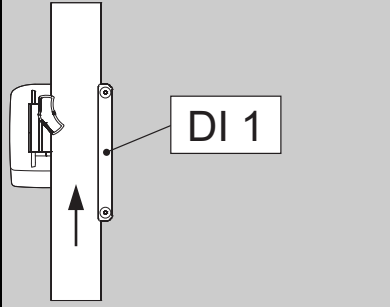
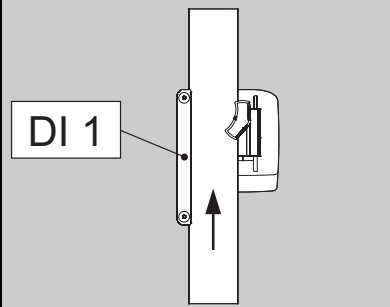
Function	Direction	Designation	Assembly mechanical/electrical	Item
Stop	Left	XUUS 11 L		XUUS 11 L
	Right	XUUS 11 R		XUUS 11 R

5.3.7 Mounting instructions, Locating station

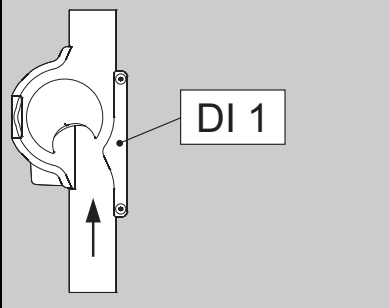
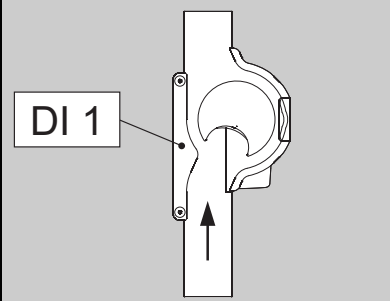
Function	Direction	Designation	Assembly mechanical/electrical	Item
Locating station	Left	XUUL 11 L		XUUL 11 L
	Right	XUUL 11 R		XUUL 11 R

5.4 Adjustment

5.4.1 Parameter setting tool

All software in the X45e motors are preloaded and the behaviour of the motors can be adjusted to different performance (such as function type, speed and angle settings) by a parameter setting tool kit, 5113070

For more information see "User documentation, Parameter setting tool" on flexlink.com and "Technical library".



6 Technical maintenance

6.1 Maintenance intervals

Within the application, where X45 equipment is normally used, environmental conditions are clean compared to many other FlexLink system installation sites. During these conditions X45 modules normally require a minimum of maintenance.

The following maintenance interval is recommended for X45 equipment:

- An inspection for all equipment is recommended regularly every 1500 operating hours or every 3rd month depending on which case that occurs first.

Table 1: Interval

	Interval
1-shift	Every 3:rd month
2-shift	Every 3:rd month
3-shift	Every 1500 hours

In case of less clean environmental conditions certain wear can occur and more frequently planned maintenance intervals are recommended. If this is the case, consult your FlexLink supplier.

7 Recommended spare parts

See separate Spare parts list on flexlink.com and "Technical library"

8 Supplier's information

This manual goes together with the module of the type mentioned on the order and on the title page of this manual. This document was drawn up by:

FlexLink Components AB

Date: 2010/01/18

Copyright: FlexLink Sweden, 2010

The machine was produced by:

Flexlink Components AB	Tel:	+46 (0)31-337 31 00
SE-415 50 Göteborg	Fax:	+46 (0)31-337 31 95
Sweden	E-mail:	info@FlexLink.se
		www.FlexLink.com



Note! *In case of failures please contact the system integrator.*

EC Declaration of Incorporation

Partly complied machinery

FlexLink Components AB
SE-41550 Göteborg
Sweden

We hereby declare that the following equipment is intended to be incorporated into a FlexLink conveyor system and thereby forming a machine. Operation is prohibited until it has been determined that the machine in which these products are incorporated, has been declared in conformity with the Machinery Directive 2006/42/EC, together with amendments which have entered into force as of the date of issue of this declaration, with particular reference to the essential health and safety requirements in connection with the design, construction and manufacture of the below specified equipment.

Conveyor modules X45

- XUUC S, XUUC SP
- XUUC V, XUUC VP
- XUUC L, XUUC LP
- XUUC U, XUUC UP

Corresponding EC directives:

Low Voltage Directive 2006/95/EC

According to 2004/108/EC Electromagnetic Compatibility Directive (EMC), the listed device is not independently operable product, but intended as part of a given fixed installation. Compliance of the directive requires the correct installation of the product, the observance of specific installation notes and product documentation.

FlexLink Components AB



Svante Anderholm
 Chief Operating Officer

Flexlink Components AB

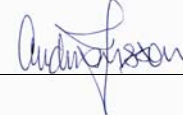

Responsible Technical file

FlexLink Components AB

Telephone: +46-31-337 31 00
 Fax: +46-31-337 22 33
 www.flexlink.com

SE-415 50 Göteborg
 Sweden