

Modular plastic belt conveyor WL

Contents

System information.....	441	Drive units – introduction.....	449
Conveyor sections.....	442	End drive units, direct drive, no slip clutch.....	450
Belts – introduction.....	443	End drive units, direct drive with slip clutch.....	451
Belts.....	444	Idler end units – introduction.....	452
Accessories for use with Friction top belt.....	444	Idler units.....	452
Conveyor frame components – introduction.....	445	Plain bends.....	453
Conveyor frame components.....	446	Vertical bends.....	454
Slide rail.....	448	Support designs.....	455

System information



Wide conveyor for transport and accumulation

The WL conveyor system offers many of the benefits of the original FlexLink conveyor system. The added advantage of a wide belt (up to 600 mm) permits effective transport and accumulation in several different configurations.

Many accessory components of the original FlexLink system will fit, including guide rail components and supports. Most components are attached by means of T-slot fasteners, ensuring maximum flexibility. Nothing is welded. Only a minimum of cutting and drilling will be required to install a conveyor and have it running.

Belt width 304/406/608 mm

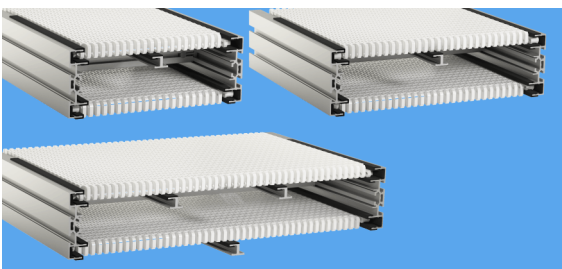

Typical applications

The WL conveyor system is designed for transport and accumulation of lightweight goods such as:

- Secondary packaging of food and hygiene products
- Pouches
- Shrink wrapped products
- Card board boxes
- Plastic containers

Technical specifications

Maximum speed.....	40 m/min
Maximum conveyor length.....	15 m
Product weight.....	up to 30 kg
Total load.....	up to 250 kg
Max. product weight per belt pitch.....	1,5 kg/slide rail

Belt tension limit:

Conveyor with bend.....	1000 N
Conveyor without bend.....	1200 N

Conveyor sections

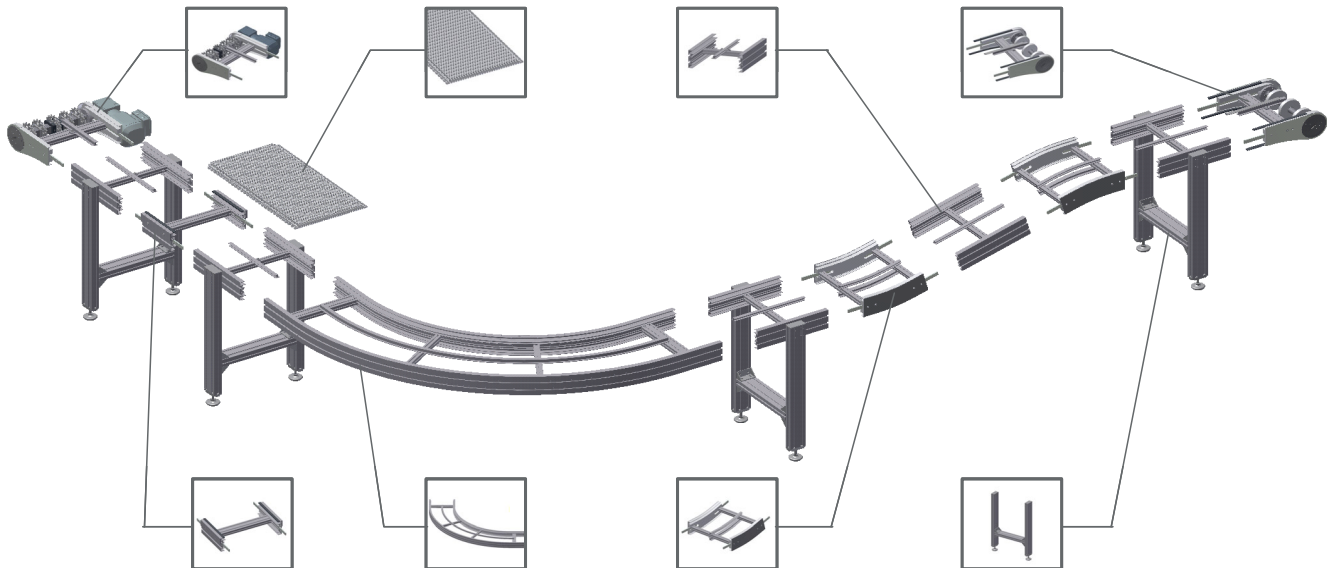

The modular plastic belt conveyor in three widths – 322, 424 and 626 mm – can be built as straight sections or in S, U or L-shape with 30, 45, 60 or 90° horizontal bend, or combinations thereof.

Vertical bends are available in 5° and 15°.

Note! A combination of horizontal and vertical curves are not recommended.

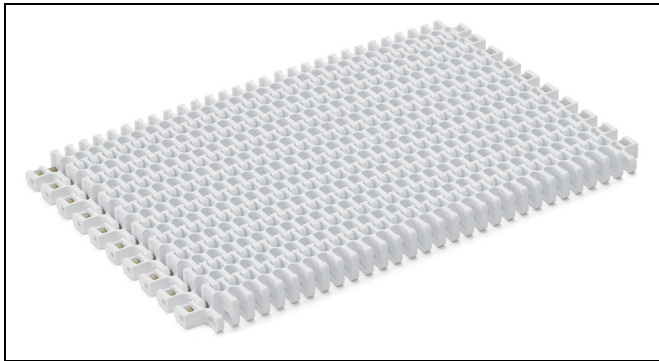

Links and plastic rods

The belt consists of plastic hinge-type links connected by plastic rods. The belt is woven together by 102 mm, 124 mm and 180 mm wide links. The assembled belt forms a wide, flat and tight conveyor surface. Three standard widths of belt can be delivered, 304 mm, 406 mm and 608 mm.

Belt type	A	B
Plain belt WLTP...H	22	22,8
Friction top belt WLTP...FA	24.1	22,8

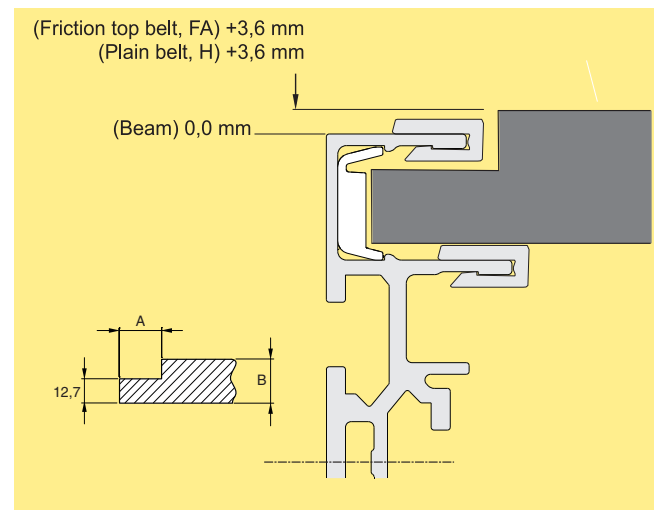

Technical characteristics

Belt width	304/406/608 mm
Belt weight (Polypropylene)	9,3 kg/m ²
Belt weight (Acetal)	14,9 kg/m ²
Belt pitch	25,4 mm
Max. permissible belt tension	
With bend	1000 N
Without bend	1200 N
Max. permissible belt tension for Friction top belt	
With bend	700 N
Without bend	1000 N
Temperature range (Polypropylene)	1 °C to +60 °C
Temperature range (Acetal)	-46 °C to +60 °C

Belt type	Belt material	Plastic rod material
Plain belt	Acetal	Polyamide
Friction top belt	Polypropylene	Acetal

Tools and accessories

No special tools are required. The belt is lubrication-free. A new belt running on new slide rails, however, will need a few hours of running-in before it runs perfectly smoothly. For applications where absolutely smooth running is essential from start, use a silicone or teflon based lubricant.

Ordering information

The belt is delivered in assembled 1 m lengths. To calculate the total length required, remember to add for belt consumed by the idler and drive units.

CC
X45
XS
X65
X65P
X85
X85P
XH
XK
XKP
X180
X300
GR
CS
XT
HU
WL
WK
XC
XF
XD
ELV
SC
FST
TR
APX
IDX

Belts

Plain belt

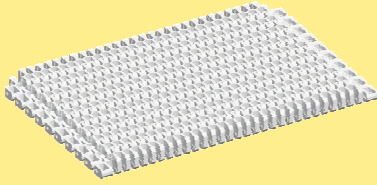

Plain belt
Length 1 m
Acetal
304 mm wide, WL322
406 mm wide, WL424
608 mm wide, WL626

WLTP 1A304L H
WLTP 1A406L H
WLTP 1A608L H

Friction top belt

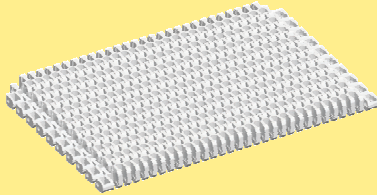

Friction top belt
Length 1 m
Polypropylene
304 mm wide, WL322
406 mm wide, WL424
608 mm wide, WL626

WLTP 1A304 FA
WLTP 1A406 FA
WLTP 1A608 FA

Friction top belt increases the friction between product and chain and can often be used for 20° slopes.

Note! Can only be used in straight sections and in combination with Vertical bends, a combination with Plain bends are not allowed

Accessories for use with Friction top belt

Roller kit

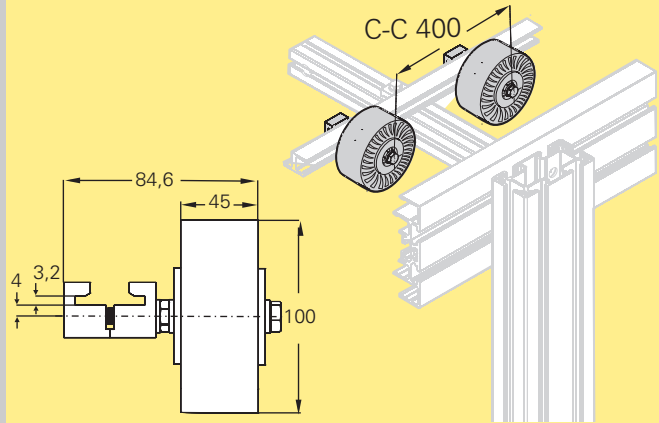

Roller kit, centre belt support
wheel/roller

FLX1001216

Kit for Friction top belt WLTP 1A608
FA, includes mounting hardware.

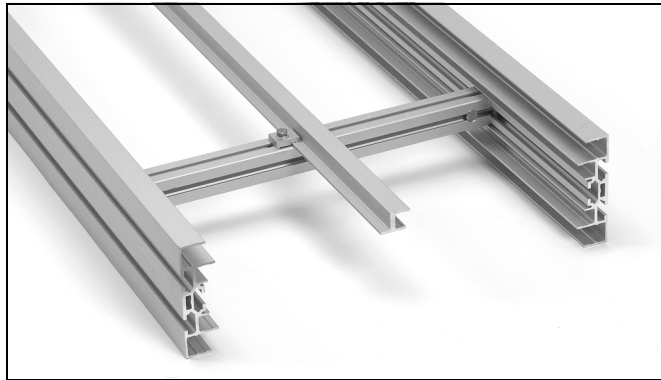

Conveyor frame structure

Frame profiles and cross bars

Conveyor frame sections are built from the following components:

- Frame profile (3 m or cut to any length from 0,5 m up to 3 m)
- Centre support profile
- Beam for cross bar
- Fastener yoke
- Mounting hardware

Each 3 m frame section consists of two frame profiles connected by four cross bars. The conveyor chain slides on the top edges of the frame profiles, and returns on the bottom side. Plastic slide rails ensure a low friction contact between chain and conveyor frame.

One or more centre support profiles is used to prevent the centre portion of the chain from sagging with heavy loads. A centre support profile should be used every 200 mm, except for very light loads. The 626 mm wide conveyor also requires a centre chain support in type of profile for standard plain belt and a Roller kit for Friction top belt on the bottom side.

Suggested support layouts are shown on page 455. For support components refer to catalogue section *Conveyor support components*.

Conveyor dimensions

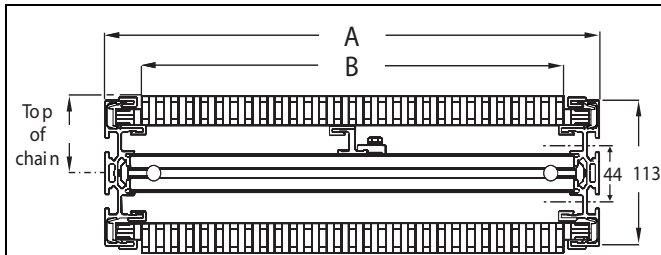

	WL 322	WL 424	WL 626
Conveyor width A	322 mm	424 mm	626 mm
Usable belt width B	260 mm	362 mm	564 mm
Top of chain:			
Standard belt WLTP...H		60 mm	
Friction top belt WLTP...F		55 mm	
Friction top belt WLTP...FA		60 mm	

Technical specifications

Typical friction between chain and slide rails after run-in:
XBCR 25 H/HB and WLCS 25x5 H..... 0,25

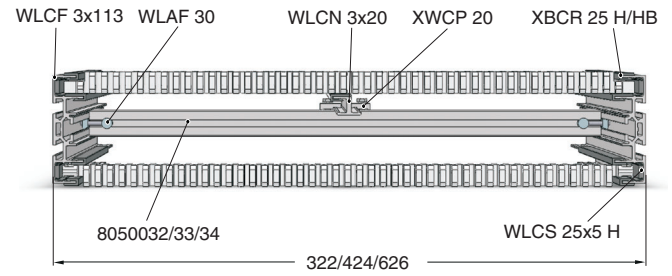

Cross-section of conveyor frame

Minimum conveyor length

Minimum conveyor length	Width	L1	L2	L3
Straight section	322	1160	-	-
	424	1160	-	-
	626	1160	-	-
L-shape section	322	550	800	-
	424	550	800	-
	626	750	1162	-
U-shape section	322	550	400	800
	424	550	400	800
	626	750	400	990
S-shape section	322	550	608	800
	424	550	812	800
	626	750	1216	990

Ordering information

Slide rail, connecting strips, and connecting sleeves must be ordered separately.

Conveyor beam

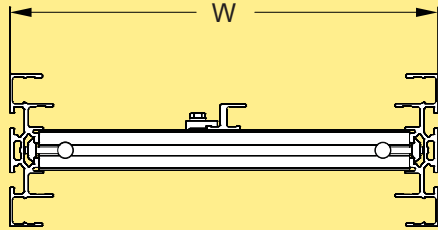

- Conveyor beam, WL322
Length 3000 mm
Length to order (500- 3000 mm) **WLCB 3A322**
WLCB LA322
- Conveyor beam, WL424
Length 3000 mm
Length to order (500- 3000 mm) **WLCB 3A424**
WLCB LA424
- Conveyor beam, WL626
Length 3000 mm
Length to order (500- 3000 mm) **WLCB 3A626**
WLCB LA626

The beam section is delivered unassembled.

Conveyor frame profile

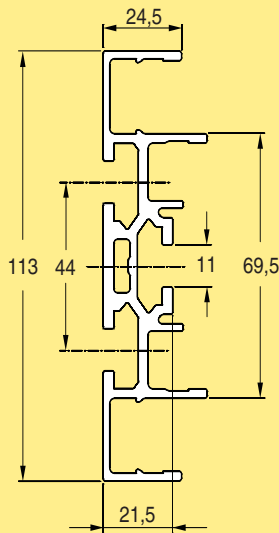

- Frame profile
Length 3000 +10/-0 mm
Length to order (30- 3000 mm) **WLCF 3x113**
WLCF Lx113

Connecting sleeve kit

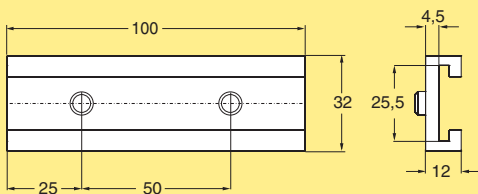

- Connecting sleeve
Length 100 mm
Including set screws **8050045**

Centre support profile

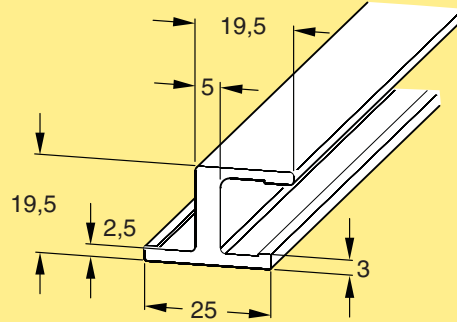

- Centre support profile
Length 3000 +10/-0 mm
Length to order (30- 3000 mm) **WLCN 3x20**
WLCN Lx20

Connecting strips for beam

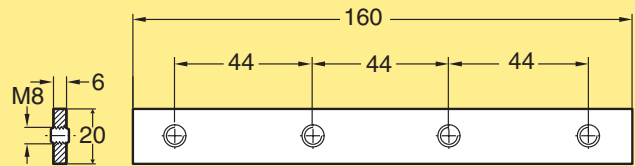

- Connecting strip **XSCJ 6x160**

Cleat

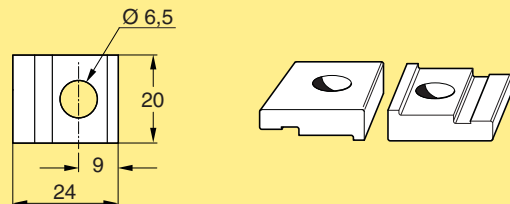

- Cleat **XWCP 20**

Mounting:

One each of MC6S 6x14, BRB 6.4x12, XFAN 6

T-slot nut

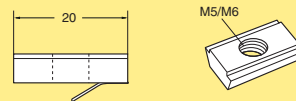

- T-slot nut
M6, multipack (10 pcs)
multipack (100 pcs)
multipack (250 pcs) **XFAN 6 Q10**
XFAN 6 Q100
XFAN 6 Q250

Support rail

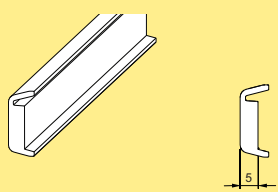

Support rail, length 25 m
PA-PE (Grey)

WLCS 25x5 H

Fastener yoke

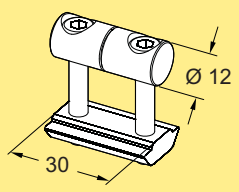

Fastener yoke
Steel, electro-zinc-plated
Length 30 mm

WLAF 30

Spacer beam

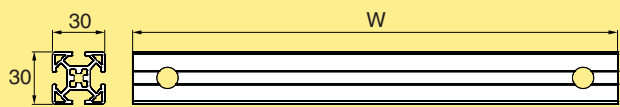
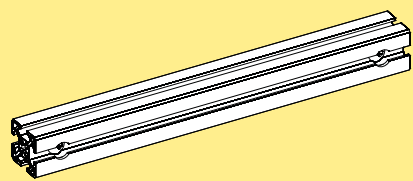
Spacer beam 30 mm x 30 mm
Length 279 mm
Length 381 mm
Length 583 mm

8050032
8050033
8050034

Support beam 30x30

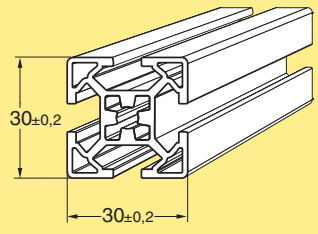

Beam 30 mm x 30 mm
Aluminium, anodized
Length 3000 mm
Length to order

XFBM 3x30
XFBM Lx30

Beam section for belt installation

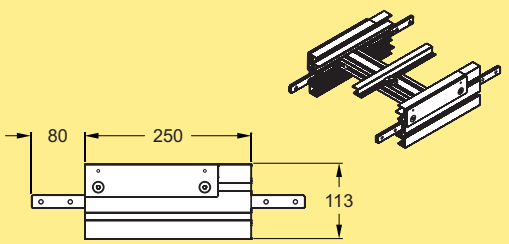

Beam section kit
WL322
WL424
WL626

WLCC 322
WLCC 424
WLCC 626

Including connection strips and screws

Cover strip for T-slot, PVC

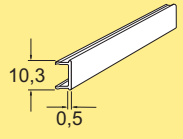

Cover strip for T-slot
Length 3 m
Grey PVC

XCAC 3 P

Note! Can't be used with bends

Cover strip for T-slot, PVC

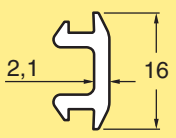
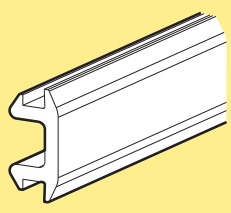
Cover strip for T-slot
Length 25 m
Grey PVC

XCAC 25 P

Cover strip for T-slot, aluminium

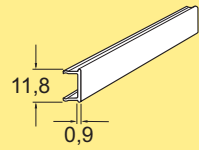

Cover strip for T-slot
Aluminium, anodized
Length 2 m

XCAC 2

Note! Can't be used with bends

CC
X45
XS
X65
X65P
X85
X85P
XH
XK
XKP
X180
X300
GR
CS
XT
HU
WL
WK
XC
XF
XD
ELV
SC
FST
TR
APX
IDX

Slide rail

Slide rail

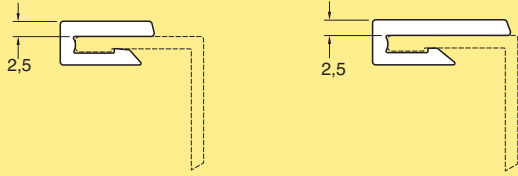

Slide rail, length 25 m
PA-PE (Grey)
PA-PE (Grey)

XBCR 25 H
XBCR 25 HB

Mounting tool for slide rail

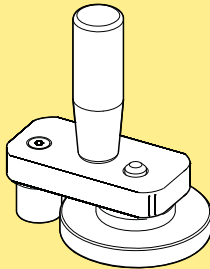

Mounting tool for slide rail

WLMR 135

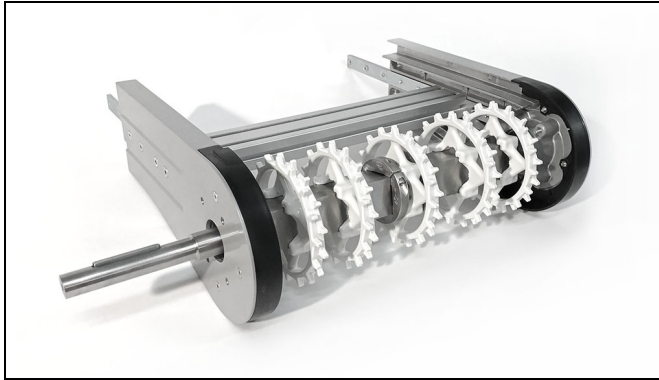

End drive unit

Drive unit types

The WL system includes direct driven units with or without slip clutch. The belt is guided through the drive unit eliminating any pinch point in the drive unit.

Available motors include variable speed types (V) as well as fixed speed motors (F).

End drive units

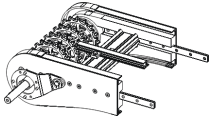
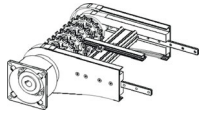
Size	Direct drive, no slip clutch	Direct drive, slip clutch
Drive unit types	 F, V	 F, V

Motor specifications

Motors are available for 230/400 V, 50 Hz and 230/460 V, 60 Hz. Variable speed motors are SEW Movimot, 380–500 V. Note that variable speed motors include a control box that adds 120 mm to the width of the motor.

IP55 available with standard oil.
IP65 available with food grade oil.

Technical specifications

Maximal speed 40 m/min
Number of teeth on sprocket wheel ... 2x16

Number of sprocket wheels vs. conveyor width

Width	322 mm	424 mm	626 mm
Sprocket wheels	5	5	7

Ordering information

Drive units with motors must be specified using the web-based configurator. The configurator provides detailed information and step-by-step guidance in the specification process. A product code string is generated, containing the specification details. See next page for examples of code strings.

Drive units *without* motors can be ordered using the designations in the catalogue.

- Connecting strips are included with the drive units.
- Slide rail must be ordered separately.

Dimension

Note that dimensions relating to drive unit motors depend on the motor specified during the configuration.

CC
X45
XS
X65
X65P
X85
X85P
XH
XK
XKP
X180
X300
GR
CS
XT
HU
WL
WK
XC
XF
XD
ELV
SC
FST
TR
APX
IDX

End drive unit L/R, WL322

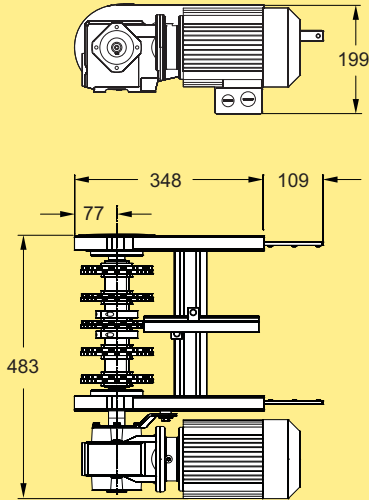

End drive unit
 Fixed/variable speed* **WLEB A322**
 Without motor:
 Transmission on left side **WLEB 0A322NLP**
 Transmission on right side **WLEB 0A322NRP**

* Use online configurator when ordering
 Effective track length: 0,80 m

End drive unit L/R, WL626

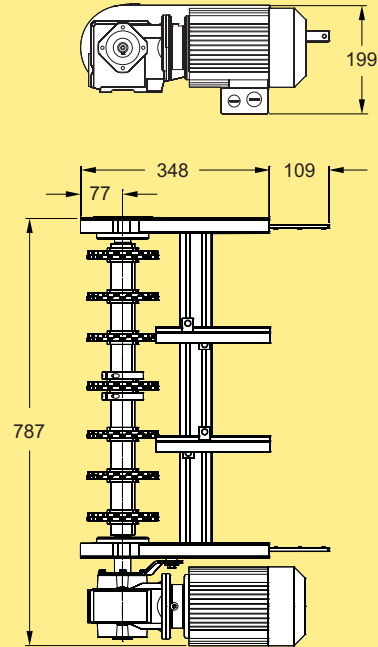

End drive unit
 Fixed/variable speed* **WLEB A626**
 Without motor:
 Transmission on left side **WLEB 0A626NLP**
 Transmission on right side **WLEB 0A626NRP**

* Use online configurator when ordering
 Effective track length: 0,80 m

End drive unit L/R, WL424

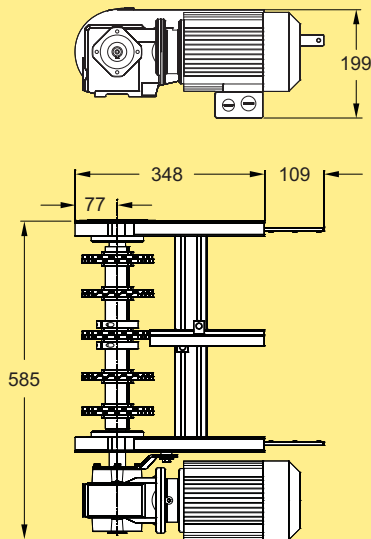

End drive unit
 Fixed/variable speed* **WLEB A424**
 Without motor:
 Transmission on left side **WLEB 0A424NLP**
 Transmission on right side **WLEB 0A424NRP**

* Use online configurator when ordering
 Effective track length: 0,80 m

End drive unit L/R with slip clutch, WL322

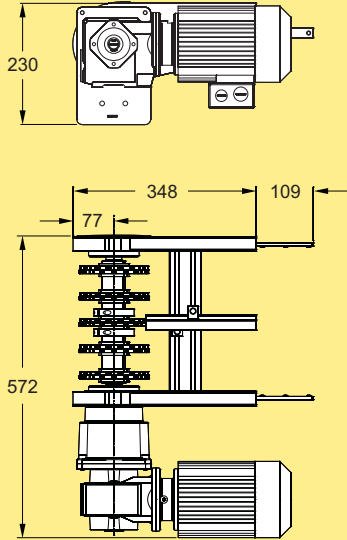

End drive unit
 Fixed/variable speed* **WLEB A322**
 Without motor:
 Transmission on left side **WLEB 0A322LP**
 Transmission on right side **WLEB 0A322RP**

* Use online configurator when ordering
 Effective track length: 0,80 m

End drive unit L/R with slip clutch, WL424

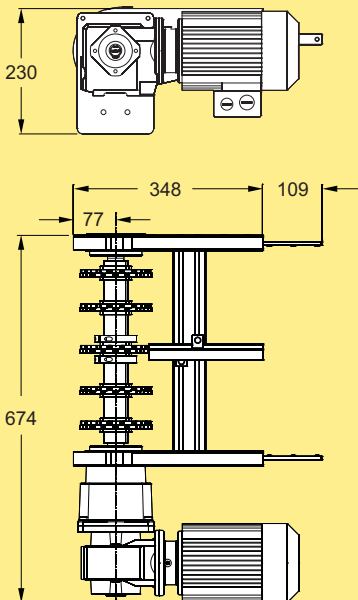

End drive unit
 Fixed/variable speed* **WLEB A424**
 Without motor:
 Transmission on left side **WLEB 0A424LP**
 Transmission on right side **WLEB 0A424RP**

* Use online configurator when ordering
 Effective track length: 0,80 m

End drive unit L/R with slip clutch, WL626

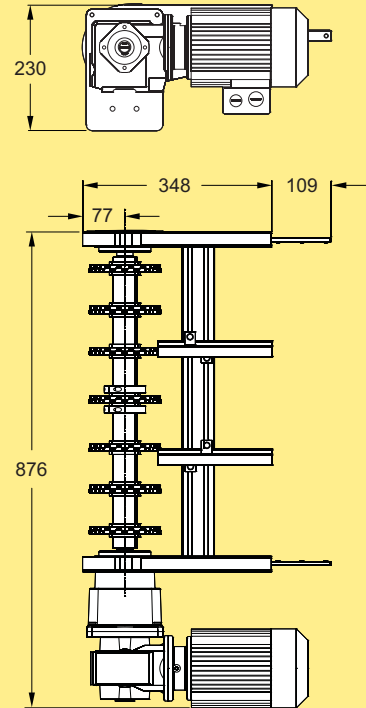

End drive unit
 Fixed/variable speed* **WLEB A626**
 Without motor:
 Transmission on left side **WLEB 0A626LP**
 Transmission on right side **WLEB 0A626RP**

* Use online configurator when ordering
 Effective track length: 0,80 m

Idler end units – introduction

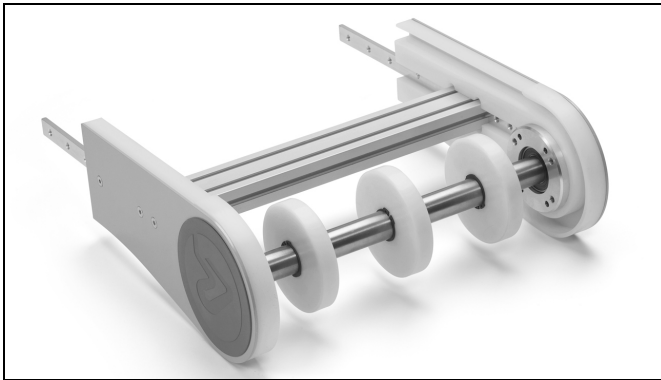

Idler end unit

Chain guidance at end of conveyor

The idler end unit is used to guide the chain from the return side of the conveyor up to the top side with a minimum of friction. The chain is guided by three or more idler wheels on a common, rotating shaft supported by ball bearings.

Number of idler wheels vs. conveyor width

Width	322 mm	424 mm	626 mm
Idler wheels	3	3	5

Ordering information

- Connecting strips are included with the idler end units.
- Slide rail must be ordered separately.

Idler units

Idler end unit, WL322

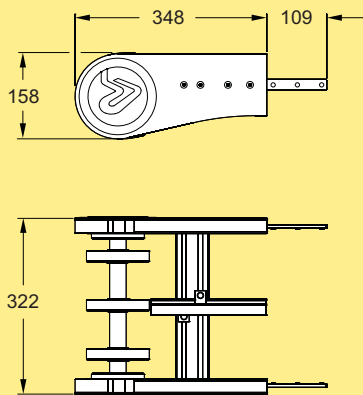

Idler end unit
Effective track length: 0,80 m

WLEJ 300A322

Idler end unit, WL626

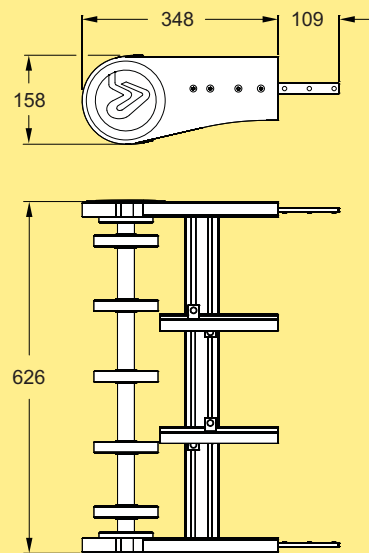

Idler end unit
Effective track length: 0,80 m

WLEJ 300A626

Idler end unit, WL424

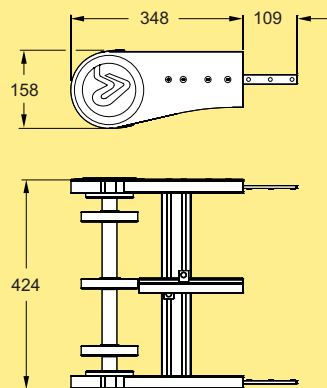

Idler end unit
Effective track length: 0,80 m

WLEJ 300A424

Plain bend, 30°

Plain bend, 30°±1°
 R=820±10 mm, WL322
 R=1100±10 mm, WL424
 R=1650±10 mm, WL626

WLBP 30A322
WLBP 30A424
WLBP 30A626

Effective track lengths:
 R820: 1,85 m (top+bottom)
 R1100: 2,20 m (top+bottom)
 R1650: 2,90 m (top+bottom)

Plain bend, 60°

Plain bend, 60°±1°
 R=820±10 mm, WL322
 R=1100±10 mm, WL424
 R=1650±10 mm, WL626

WLBP 60A322
WLBP 60A424
WLBP 60A626

Effective track lengths:
 R820: 2,85 m (top+bottom)
 R1100: 3,55 m (top+bottom)
 R1650: 4,90 m (top+bottom)

CC
 X45
 XS
 X65
 X65P
 X85
 X85P
 XH
 XK
 XKP
 X180

Plain bend, 45°

Plain bend, 45°±1°
 R=820±10 mm, WL322
 R=1100±10 mm, WL424
 R=1650±10 mm, WL626

WLBP 45A322
WLBP 45A424
WLBP 45A626

Effective track lengths:
 R820: 2,35 m (top+bottom)
 R1100: 2,90 m (top+bottom)
 R1650: 3,90 m (top+bottom)

Plain bend, 90°

Plain bend, 90°±1°
 R=820±10 mm, WL322
 R=1100±10 mm, WL424
 R=1650±10 mm, WL626

WLBP 90A322
WLBP 90A424
WLBP 90A626

Effective track lengths:
 R820: 3,85 m (top+bottom)
 R1100: 4,90 m (top+bottom)
 R1650: 6,95 m (top+bottom)

X300
 GR
 CS
 XT
 HU
WL
 WK
 XC
 XF
 XD
 ELV
 SC

FST
 TR
 APX
 IDX

Vertical bends

Vertical bend, 5°

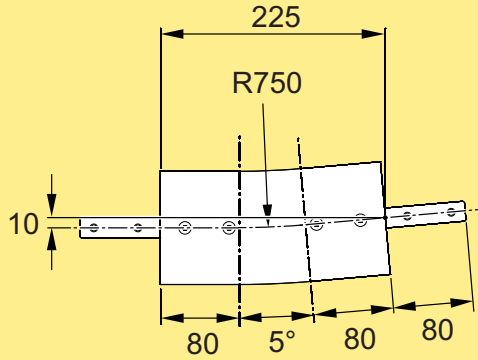

- Vertical bend, 5°, WL322 **WLBV 5A322**
- Vertical bend, 5°, WL424 **WLBV 5A424**
- Vertical bend, 5°, WL626 **WLBV 5A626**

Effective track length: 0,50 m (top+bottom)

Vertical bend, 15°

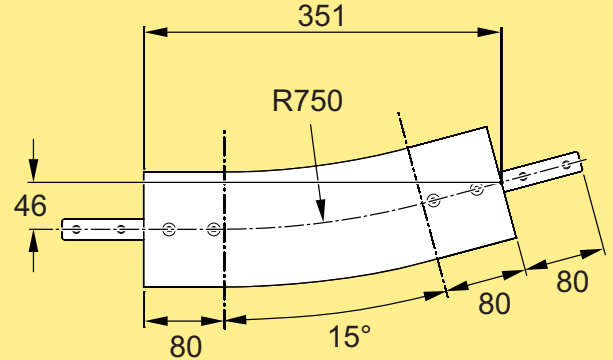

- Vertical bend, 15° WL322 **WLBV 15A322**
- Vertical bend, 15° WL424 **WLBV 15A424**
- Vertical bend, 15° WL626 **WLBV 15A626**

Effective track length: 0,75 m (top+bottom)

Support components

The illustrations on this page show recommended supports for the conveyor. All supports are built using components from FlexLink structural system XC. See main catalogue section *Conveyor support components* for more information.

System WL626 requires some additional support, please see page 456 for details.

Height and width of supports Type 1 and 2

	WL322	WL424	WL626
W1 (mm)	322	424	626
L1 (mm)	ca. H1-100	ca. H1-100	ca. H1-100
W2 (mm)	172,5	274,5	476,5
L2 (mm)	ca. H2-284	ca. H2-284	ca. H2-284

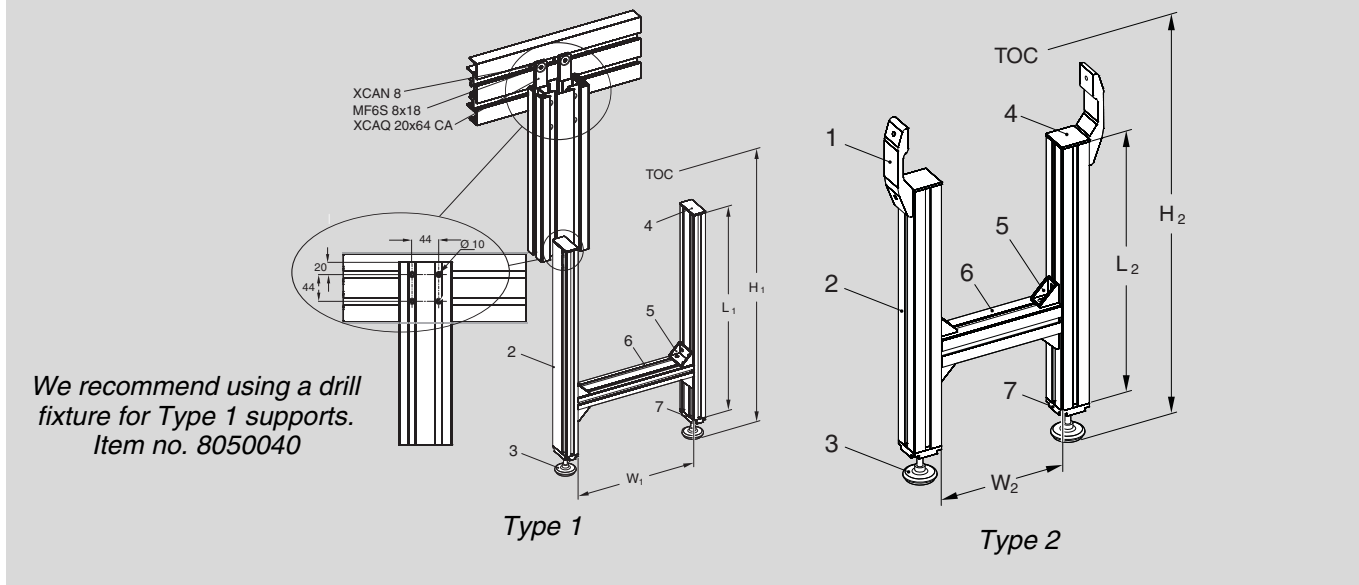

Suggested support components

Pos	Item	Designation	
		Type 1	Type 2
1	Beam support bracket	–	XLCS 64 C
2	Leg support	XCBL 3x44x88	XCBL 3x64
3	Foot	XCFS 12x68	XCFS 12x68
4	End cap	XCBE 44x88	XCBE 64
5	Angle bracket	XCFA 88 B	XCFA 44 B
6	Cross beam	XCBL 3x44x88	XCBL 3x64
7	End plate for beam	XCFE 44x88 M12A	XCFE64 M12A

PO
CC
X45
XS
X65
X65P
X85
X85P
XH
XK
XKP
X180
X300
GR
CS
XT
HU
WL
WK
XC
XF
XD
ELV
SC
FST
TR
APX
IDX

Additional support for WL626

System WL626 requires extra support due to the width of the conveyor.

Plain belt WLTP 1A608 L H			
Pos	Item	Designation	
1	Cleat	XWCP 20	
2	Support profile 669 mm	XFBM Lx30	
3	Support bracket	XLDB 21x100	
4	Cross beam	XCBL 3x44x88	Used together with leg support XCBL 3x44x88
4	Cross beam	XCBL 3x64	Used together with leg support XCBL 3x64
A	Fastening material	XFAN 6, MC6S 6x14, BRB 6,4x12	
B	Fastening material	XCAN 8, M6S 8x14	

Friction top belt WLTP 1A608 FA			
Pos	Item	Designation	
1	Cleat	XWCP 20	
2	Support profile 625 mm	XFBM Lx30	
3	Support bracket	FLX1001249	
4	Cross beam	XCBL 3x44x88	Used together with leg support XCBL 3x44x88
4	Cross beam	XCBL 3x64	Used together with leg support XCBL 3x64
A	Fastening material	XFAN 6, MC6S 6x14, BRB 6,4x12	
B	Fastening material	XLAT 17, BRB 8,4 x16, XLAN 8	
C	Fastening material	BRB 8,4 x 16, MC6S-TT 6 x 30	

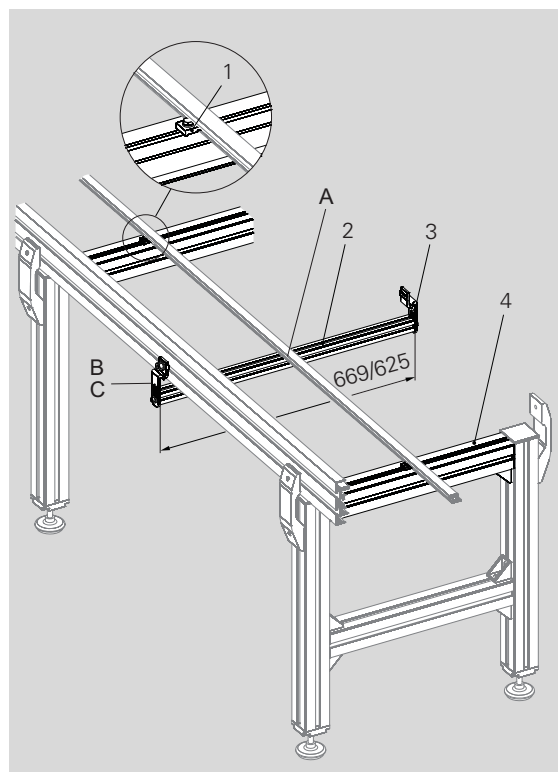

Drill fixture

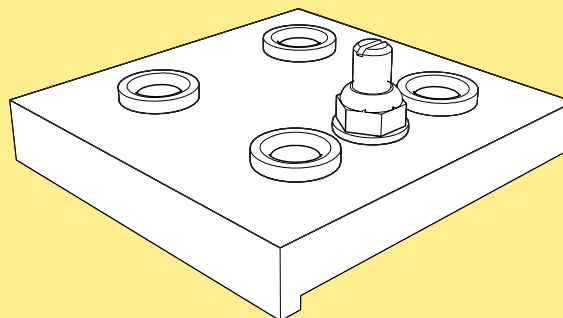

Drill fixture

8050040

See figure "Suggested support components" on page 455