

PRE-REQUISITES

Recommended tools

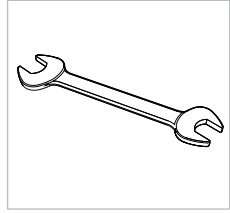

SAFETY

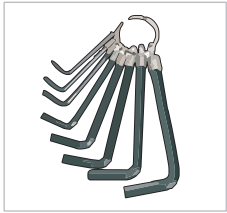

WARNING
The system must not be operated without safety equipment properly mounted.



WARNING
At installation, maintenance and service, make sure the motor is shut off.



WARNING
Pinch Point

COMPONENTS

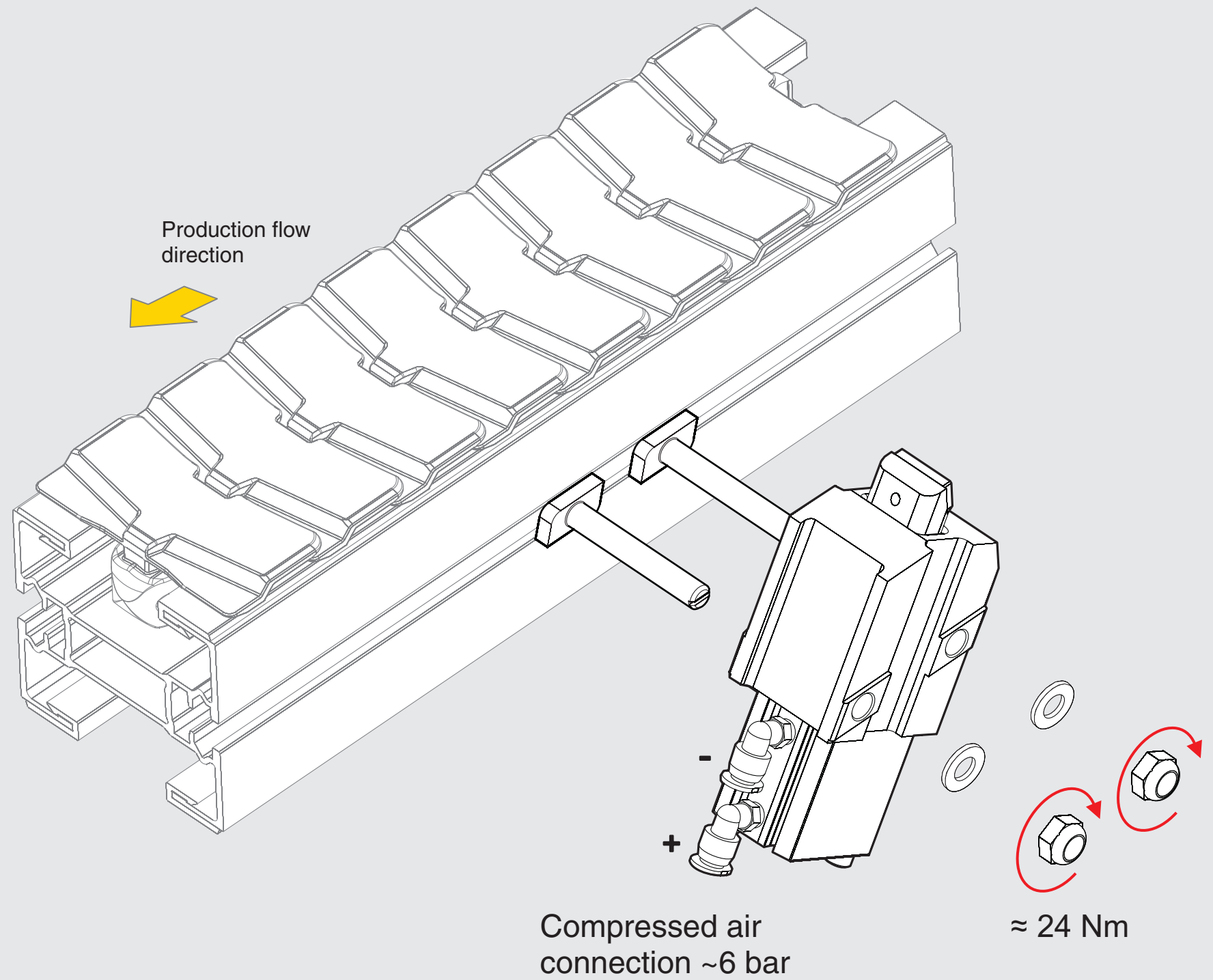
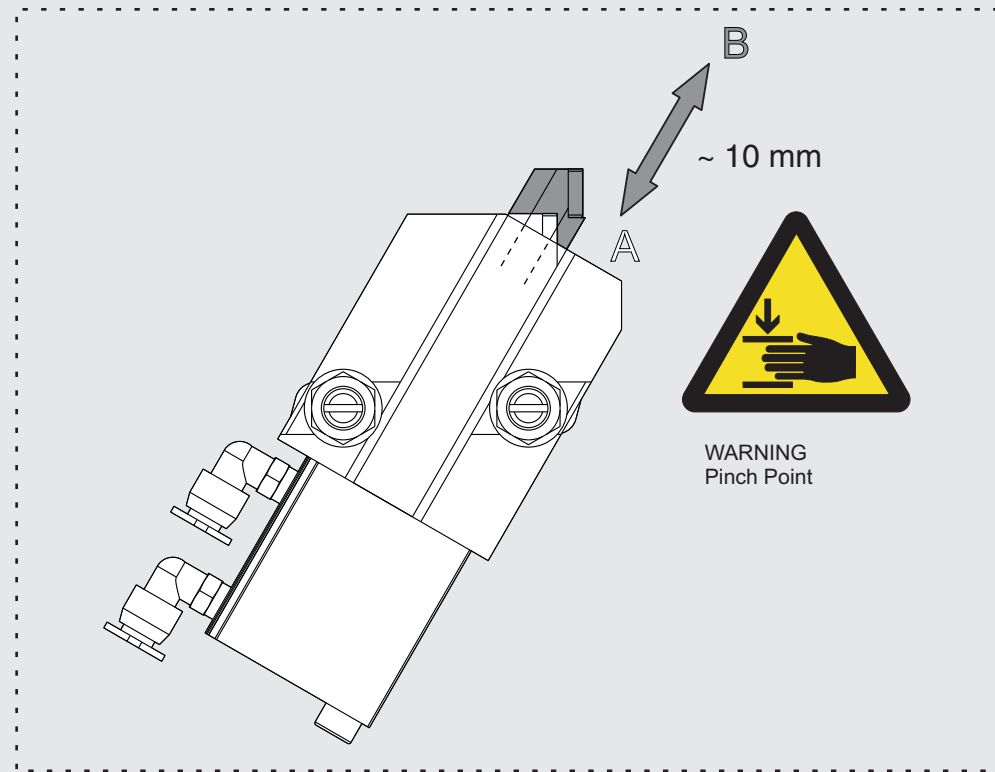
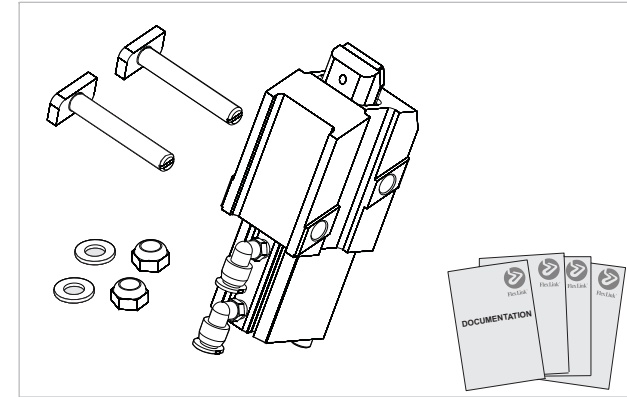

FlexLink Components AB
SE-41550 Göteborg
Sweden

We hereby declare that the following equipment is intended to be incorporated into a FlexLink conveyor system and thereby forming a machine. Operation is prohibited until it has been determined that the machine in which these products are incorporated, has been declared in conformity with the Machinery Directive 2006/42/EC, together with amendments which have entered into force as of the date of issue of this declaration, with particular reference to the essential health and safety requirements in connection with the design, construction and manufacture of the below specified equipment.

- Pneumatic stop XMPD 20x10 EA

ASSEMBLY INSTRUCTION

**Pneumatic Stop
XMPD 20x10 EA**

FlexLink Components AB



Svante Anderholm
Chief Operating Officer

Flexlink Components AB



Anders Jonsson
Responsible Technical file

FlexLink Components AB

