

PRE-REQUISITES

SAFETY

COMPONENTS



Recommended tools

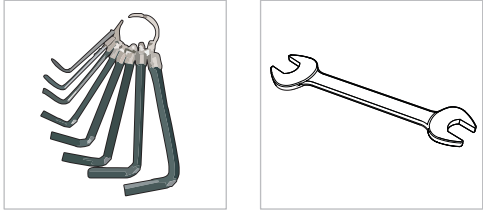

WARNING
The system must not be operated without safety equipment properly mounted.



WARNING
At installation, maintenance and service, make sure the motor is shut off.



WARNING
Pinch Point



CAUTION
Due to heavy weight - 2 person lift, or mechanical lift equipment.

0-unit

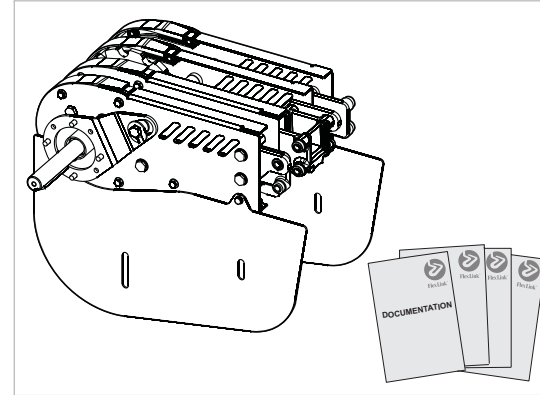

Drive Unit

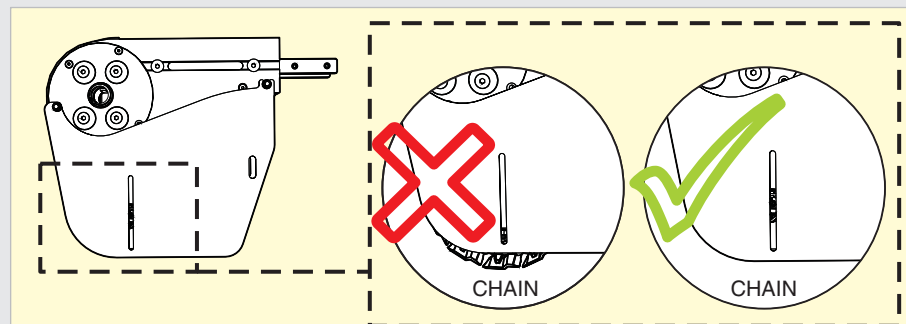
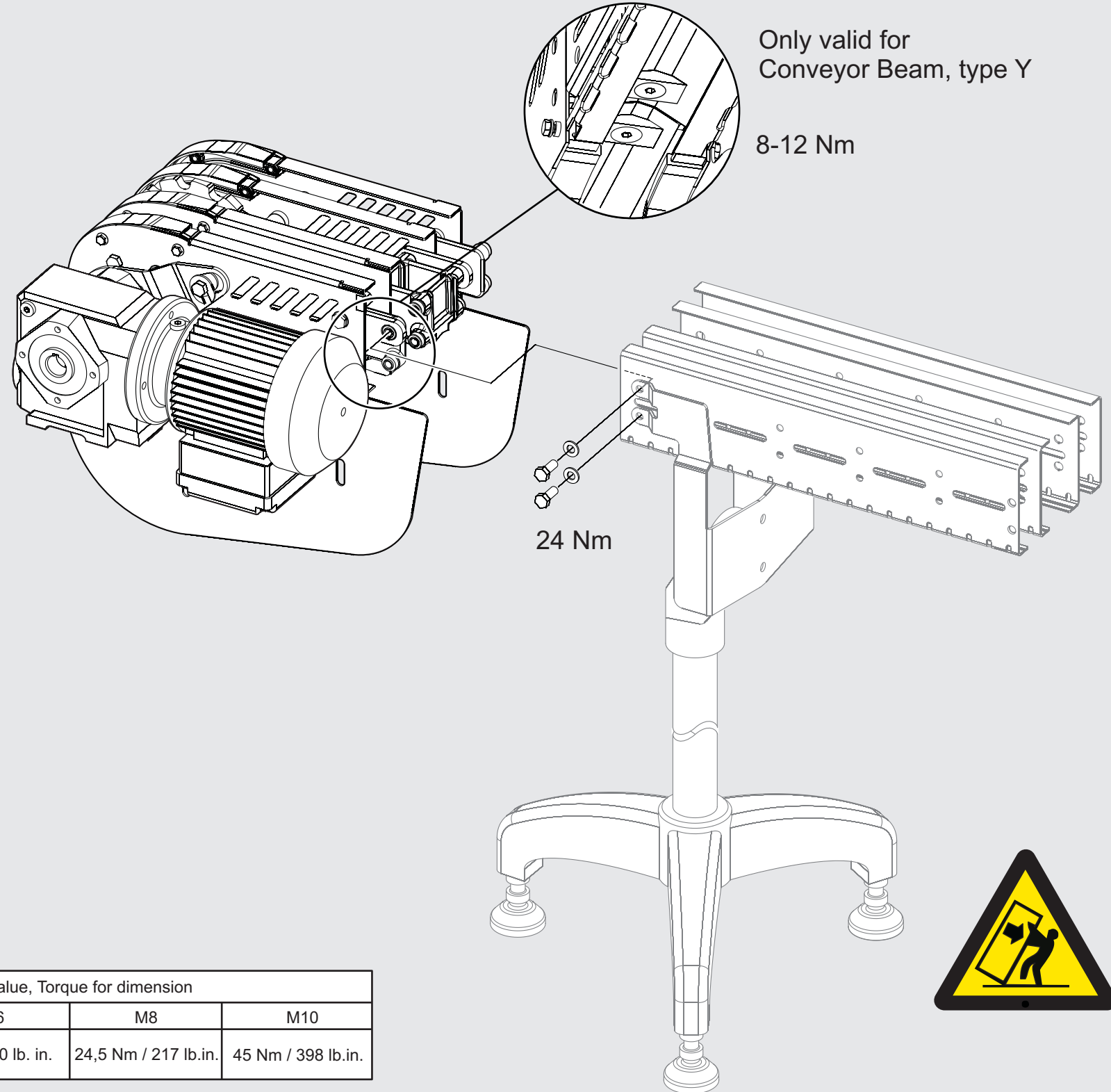
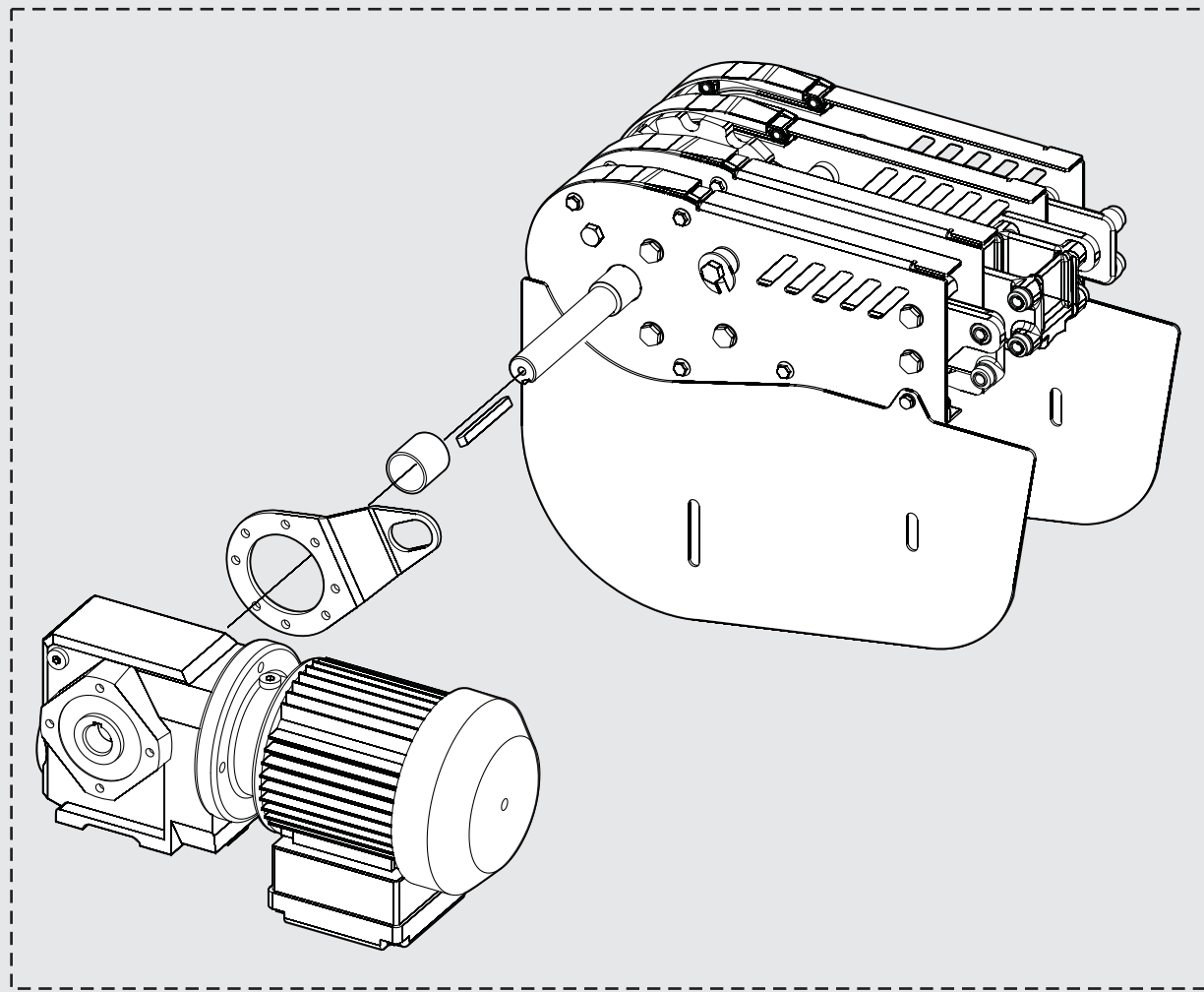
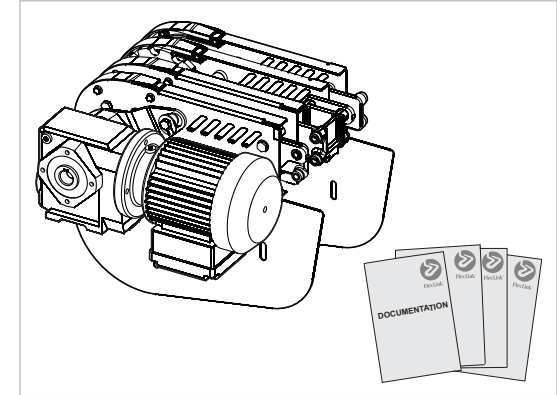

CAUTION
The conveyor chain must be maintained during system lifetime. If the conveyor chain is too long, it must be shortened.

| Basic value, Torque for dimension | | | |
|-----------------------------------|-------------------|----------------------|--------------------|
| M5 | M6 | M8 | M10 |
| 4 Nm / 35 lb. in. | 9 Nm / 80 lb. in. | 24,5 Nm / 217 lb.in. | 45 Nm / 398 lb.in. |

FlexLink Components AB
SE-41550 Göteborg
Sweden

We hereby declare that the following equipment is intended to be incorporated into a FlexLink conveyor system and thereby forming a machine. Operation is prohibited until it has been determined that the machine in which these products are incorporated, has been declared in conformity with the Machinery Directive 2006/42/EC, together with amendments which have entered into force as of the date of issue of this declaration, with particular reference to the essential health and safety requirements in connection with the design, construction and manufacture of the below specified equipment.

- End Drive Unit for X180X, XBEBX0A180HN_P, XBEBX0A180HN_GP

ASSEMBLY INSTRUCTION

End Drive Unit for X180X
XBEBX0A180HN_P
XBEBX0A180HN_GP

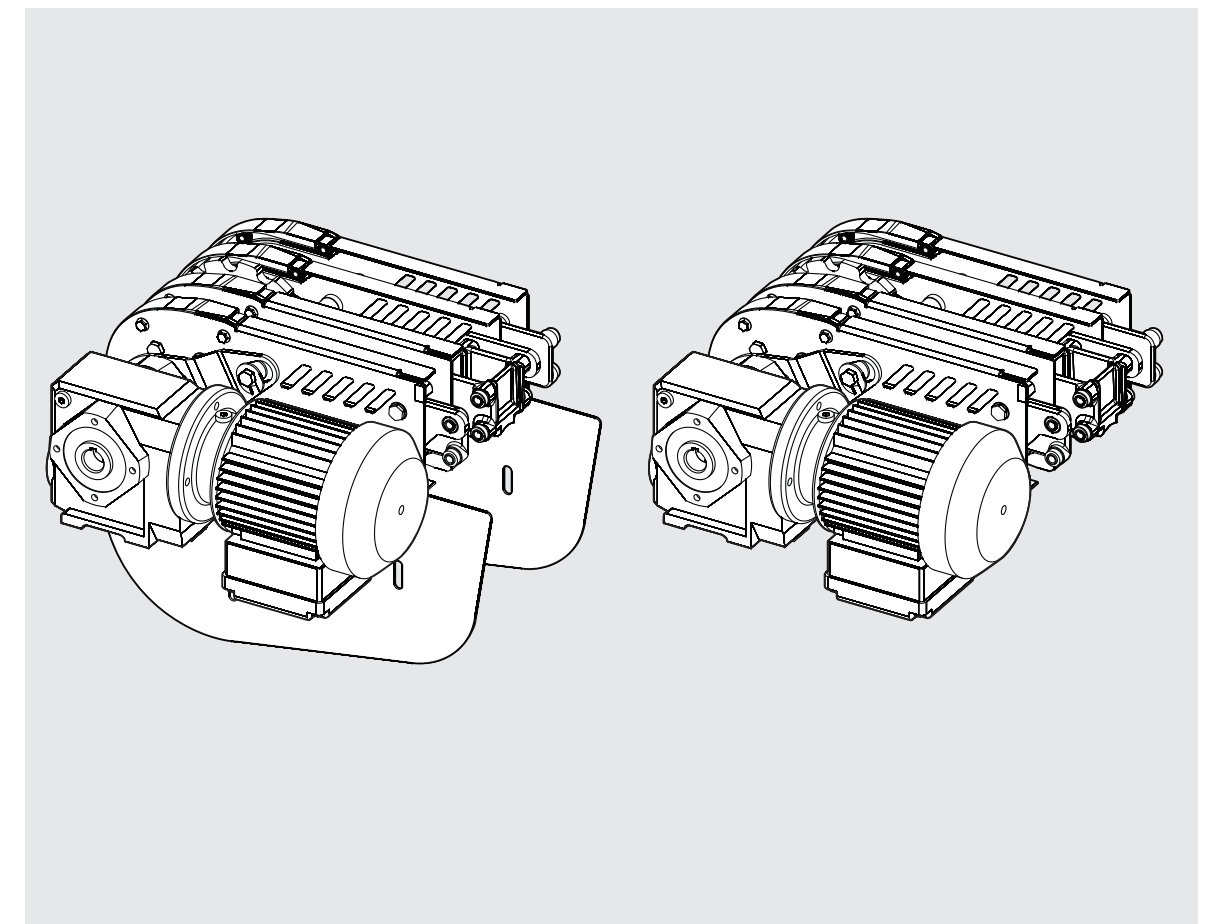

FlexLink Components AB



Svante Anderholm
Chief Operating Officer

Flexlink Components AB



Anders Jonsson
Responsible Technical file

FlexLink Components AB