

Chains X65Y

Plain chain

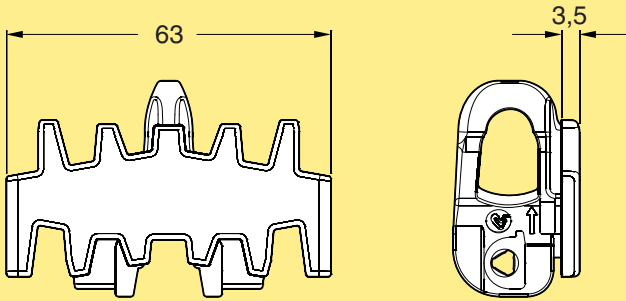

Plain chain
Length 5 m

XLTP 5A65

Plain link kit *

5117329

Plain chain (Ultra low wear)
Length 5 m

XLTP 5A65 C

Plain link kit (Ultra low wear)

5117371

**Link kit contains 10 links, 10 pivots, 10 steel pins*

Flat friction top chain

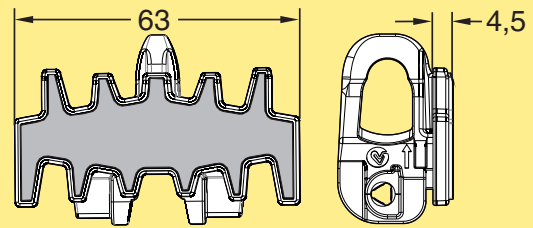

Flat friction top chain
Length 5 m, (PAR1)
Length 5 m

XLTP 5A65 FA
XLTP 5A65 FAP

**Use the online configurator to specify and order.*

Cleated link kit **

5117357

***Link kit contains 10 links, 10 pivots, 10 steel pins*

Chain accessories X65Y

Plastic pivot



Plastic pivot X65

5117478

Plastic pivot kit contains 25 items

Steel pin kit

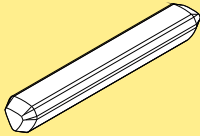

Steel pin kit

5116330

Note. kit contains 25 pcs of XTTD 4,5x30

Pin insertion tool for chain

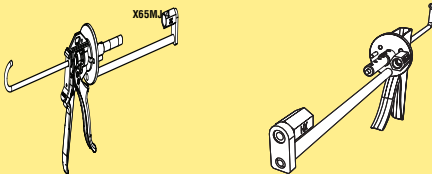

Pin insertion tool

X65

X65 PRO version*

XLMJ 4

XLMJ 4 P

**This product is recommended for frequent users.*

Conveyor beam

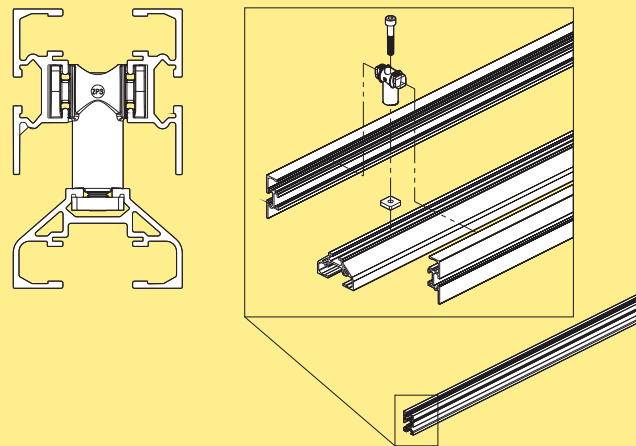

Beam
 Length 3000 mm
 Length to order (500- 2999 mm) **XLCB 3A65Y**
XLCB LA65Y

Slide rail: see page 4.
 Beam accessories: see below.

Spacer kit

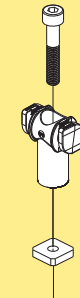

Spacer kit **XLCE A65Y**

Note. Must be ordered in multiples of 10.

CC
 X45
 XS
 X65
 X65P
X65Y
 X85

Profile for split conveyor beam

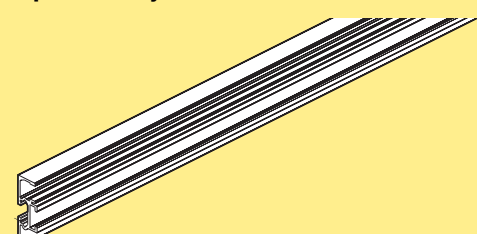

Profile
 Length 3000 +10/-0 mm
 Length to order (30- 2999 mm) **5995978 3**
5995978 L

Slide rail: see page 4.
 Beam accessories: see below.

Connecting strip with set screws

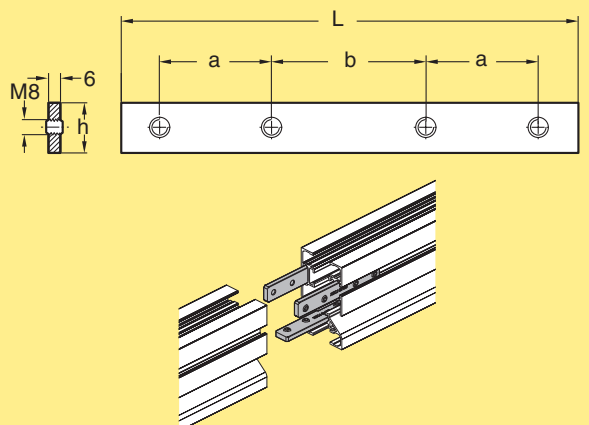

Connecting strip with set screws
 h=20, a=30, b=50, L=130 **XSCJ 6x130**

Note. Must be ordered in multiples of 10

X85P
 XH
 XK
 XKP
 X180
 X300
 GR
 CS
 XT
 HU

Profile

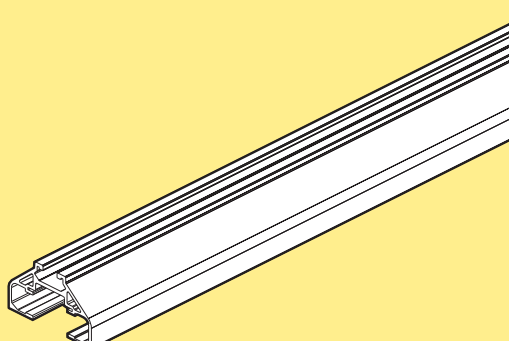

Profile
 Length 3000 +10/-0 mm
 Length to order (30- 2999 mm) **5995979 3**
5995979 L

Slide rail: see page 4.
 Beam accessories: see below.

WL
 WK
 XC
 XF
 XD
 ELV
 CTL
 FST
 TR
 APX
 IDX

Fixture

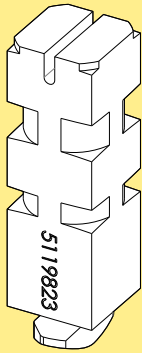

Y-Beam cut fixture

5119823

Cover strip for T-slot, PVC

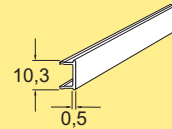

Cover strip for T-slot
Length 3 m
Grey PVC

XCAC 3 P

Note! Can't be used with bends

Cover strip for T-slot, PVC

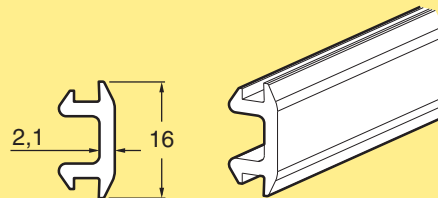

Cover strip for T-slot
Length 25 m
Grey PVC

XCAC 25 P

Cover strip

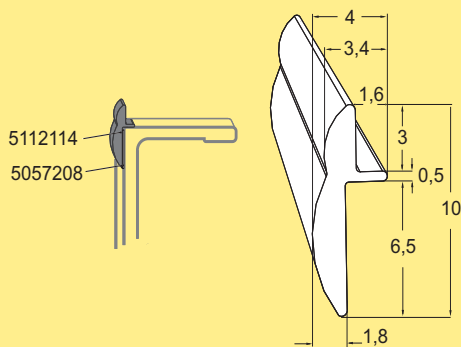

Cover strip

Length: 3 m
Material: Plastic PA 12

5112114

Cover the opening on the side between the chain and beam. Primarily for straight sections and the outer curves, but can also be mounted on inner curves. Apply using Glue tape 5057208, see mounting instruction 5497EN in Technical library.

Cover strip for T-slot, aluminium

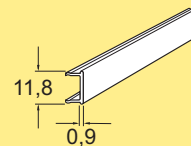

Cover strip for T-slot
Aluminium, anodized
Length 2 m

XCAC 2

Note! Can't be used with bends

Slide rails X65Y

Plastic slide rails, narrow

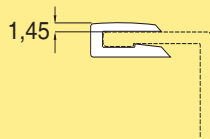

Slide rail

Length 25 m
HDPE (Black)
PA-PE (Grey)
PVDF (Natural white)
PE-UHMW (White)
PE-UHMW conductive (Black)

XLCR 25
XLCR 25 H
XLCR 25 P
XLCR 25 U
XLCR 25 E

Plastic slide rails for X65

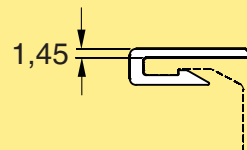

Slide rail

Length 25 m
HDPE ($\mu=0,1-0,25$) (Black)
PA-PE ($\mu=0,1-0,25$) (Grey)

XLCR 25 B
XLCR 25 HB

Not for use in bends

Steel slide rail for X65 beams

XLCR 3 TA



Slide rail ($\mu=0,15-0,35$)

Length 3 m

Acid resistant stainless steel

XLCR 3 TA

Mounting tool for slide rail



Mounting tool for slide rail XS, X65 **XLMR 140**

Aluminium rivets

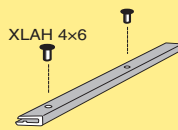

Aluminium rivets 4 mm for X65 conveyors

XLAH 4x6

*Extra slide rail in plain bends must be anchored using plastic screws due to lack of space for the rivet crimping tool.
Note. Must be ordered in multiples of 250.*

Plastic screws for slide rail

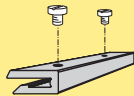

Plastic screws 5 mm for XS-X65-X85-XH-X180/X300 beams

XLAG 5

See mounting instruction in product catalogue "Anchoring slide rail using plastic screws" on page 466

Note. Must be ordered in multiples of 50

Drill fixture for slide rail

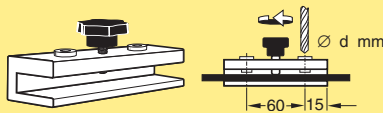

Drill fixture for X65-X85-XH-XK-X180/X300 slide rail

d=4,2 mm

3920500

Rivet crimping pliers



Rivet crimping pliers for X65-X85-XH-XK-X180/X300

For 4 mm rivets

5051395

Rivet crimping clamp

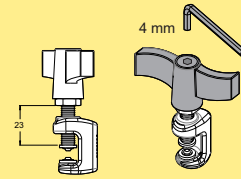

Rivet crimping clamp for X65-X85-XH-XK-X180/X300

For 4 mm rivets

3923005

CC

X45

XS

X65

X65P

X65Y

X85

X85P

XH

XK

XKP

X180

X300

GR

CS

XT

HU

WL

WK

XC

XF

XD

ELV

CTL

FST

TR

APX

IDX

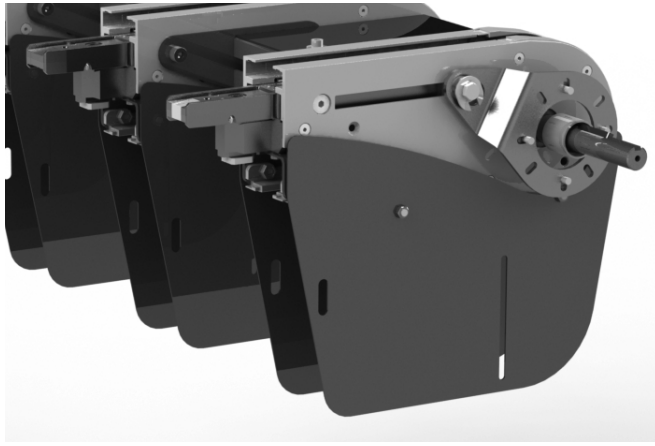

Drive unit types

The X65Y system includes single, quadruple and quintuple drive units.

Drive units can only be ordered as 0-units (without motor). Torque arm kit is included. Motor has to be ordered separately.

End drive units, direct drive, no slip clutch

End drive units L/R

NOTE! Motor is not included in the delivery

End drive unit, Single

Without motor:

Transmission on left side **5119146**
 Transmission on right side **5119147**

End drive unit, Quadruple, c-c 200

Without motor:

Transmission on left side **5119961**
 Transmission on right side **5120016**

End drive unit, Quadruple, c-c 240

Without motor:

Transmission on left side **5119962**
 Transmission on right side **5120018**

End drive unit, Quintuple, c-c 200

Without motor:

Transmission on left side **5120057**
 Transmission on right side **5120058**

End drive unit, Quintuple, c-c 240

Without motor:

Transmission on left side **5120059**
 Transmission on right side **5120060**

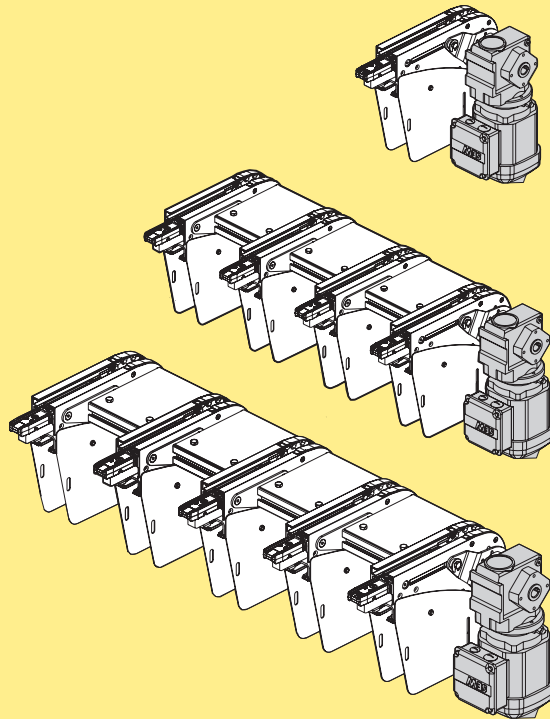

Effective track length: 0,8 m x 1-5 lanes

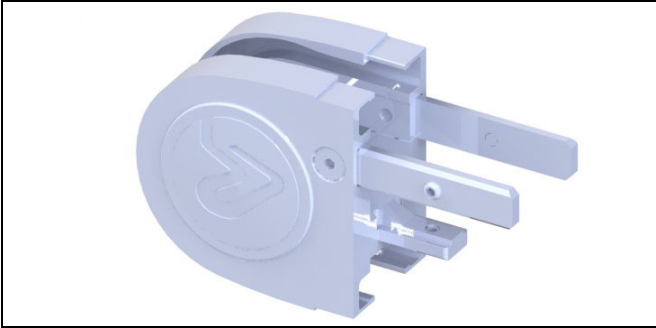

Idler end unit

Chain guidance at end of conveyor

The idler end unit is used to guide the chain from the return side of the conveyor up to the top side with a minimum of friction. The chain is guided by two or more idler wheels on a common, rotating shaft supported by ball bearings.

Ordering information

- Connecting strips are included with the idler end units.

CC

X45

XS

X65

X65P

X65Y

X85

Idler units

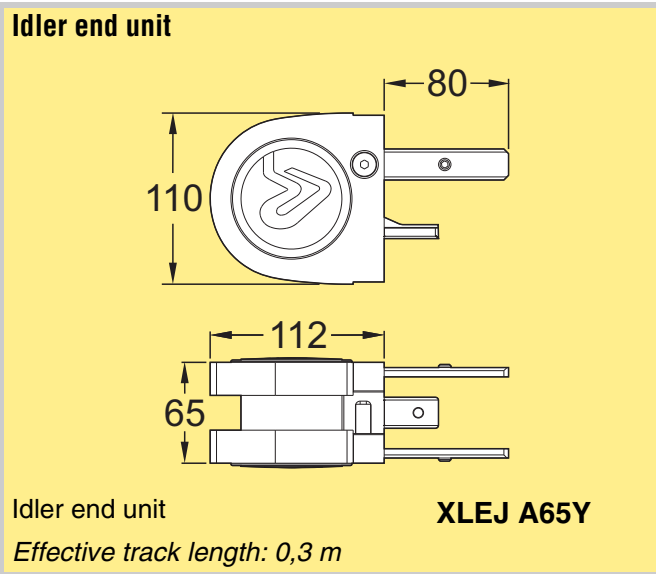

X85P

XH

XK

XKP

X180

X300

GR

CS

XT

HU

WL

WK

XC

XF

XD

ELV

CTL

FST

TR

APX

IDX

