

# Modular belt conveyor WL526X

## Contents

System information.....	147	Drive units – configuration strings .....	158
Conveyor sections.....	148	End drive units .....	159
Modular Belts - Introduction .....	149	Idler end units – Introduction.....	161
Modular belts .....	150	Idler units.....	161
Conveyor Beams - Introduction.....	152	Additional features .....	162
Conveyor frame components .....	155	Plain Bends - Introduction.....	163
Slide rail .....	156	Support System Modules - Introduction .....	166
End Drive Units - Introduction.....	157		

## System information



PO  
X70X  
X85X  
X180X  
X300X  
WL  
222X

### System overview

FlexLink's newly developed stainless steel conveyor is designed to fit into demanding primary and secondary packaging applications. It addresses important aspects of today's packing processes, such as being easy to clean, smooth handling of products, safe for operators, robust design, long life, and easy to maintain with a low cost of ownership.

The modularized and standardized design ensures fast set up, and facilitates rapid future extensions and changes.

### Technical specifications

Maximum speed:	40 m/min
Maximum conveyor length:	20 m
Max single item weight:	up to 30 kg
Total load on a conveyor:	300 kg
Max product weight per belt pitch:	1,5 kg/slide rail
Max permissible pull force (with bends):	1000 N
Max permissible pull force (without bends):	1200 N

WL  
273X  
WL  
374X  
WL  
526X  
WL  
678X  
CSX  
GRX  
FSTX  
TR  
APX  
IDX

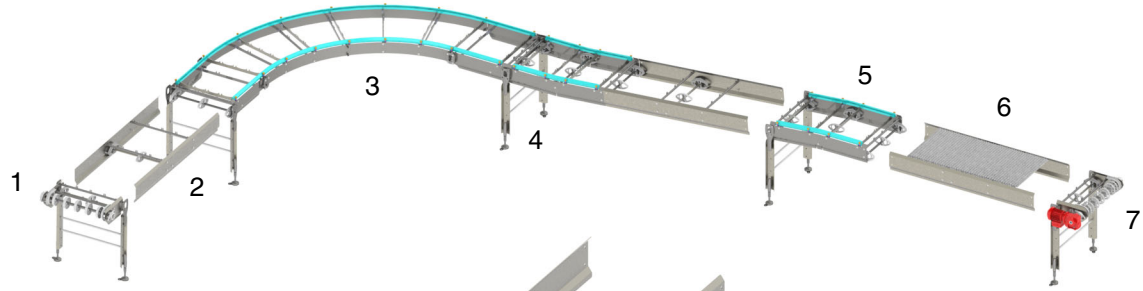

1. Idler end units



2. Conveyor beams



3. Plain bends

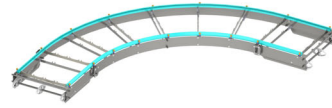

4. Support modules

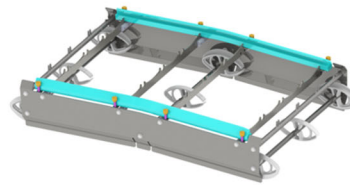

5. Vertical bends

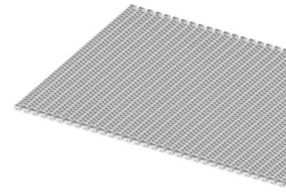

6. Modular belts



7. End drive units

The modular plastic belt conveyor in five widths – 222, 273, 374, 526 and 678 mm – can be built as straight sections or in S, U or L-shape with 30, 45, 60, 90° (180° only for 222 and 273) horizontal bend, or combinations thereof. Vertical bends are available in 5° (3° only for 222 and 273) positive or negative.

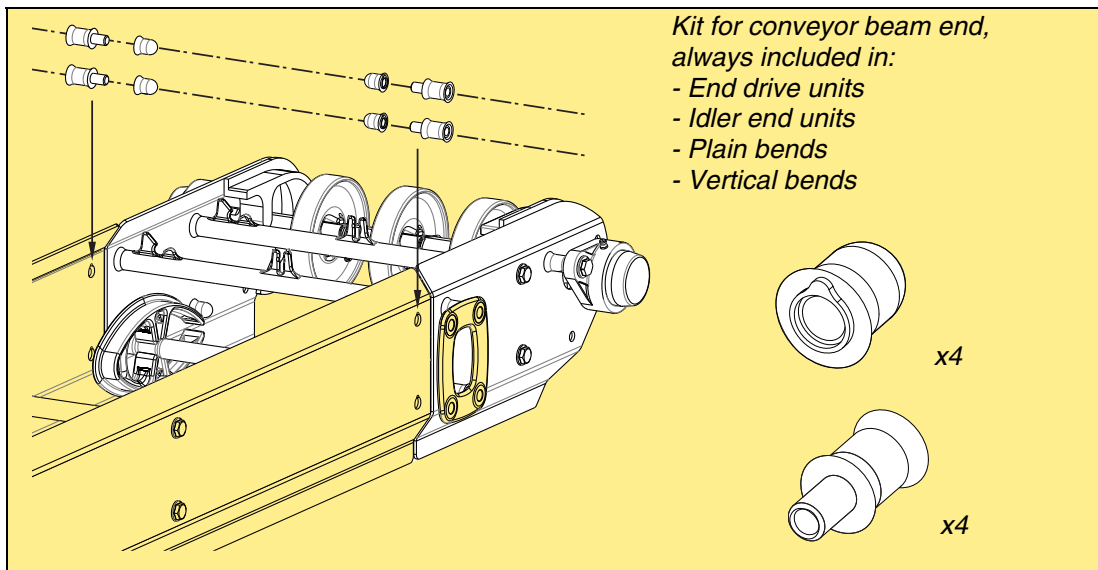

# Modular Belts - Introduction



## Modular belt, Radius flush grid, curve-running

The belt consists of plastic hinged links connected by plastic rods. The wide belts are woven together by links that are 102 mm, 124 mm, and 180 mm wide. The assembled belt forms a wide, flat, and tight conveyor surface. Five standard widths of belt can be delivered: 152 mm, 203 mm, 304 mm, 456 mm, and 608 mm.

Standard belt color is white but blue belts can also be ordered.

Belts with polyamide pins are available for dry or semi-wet applications. In constant wet applications, belts with acetal pins must be used. This is due to the fact that polyamide pins will absorb water and swell in wet applications, and acetal pins will squeak in dry environments.

## Flat top belt, straight running

The belt has a minimal number of seams and has open hinges that are easy to clean. The belt is white and is available with acetal pins for wet applications

Travel direction of the belts:

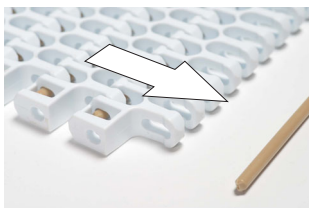

Radius flush grid

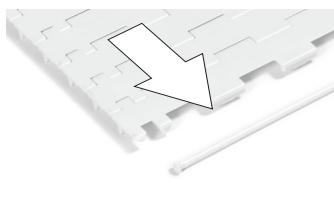

Flat top belt

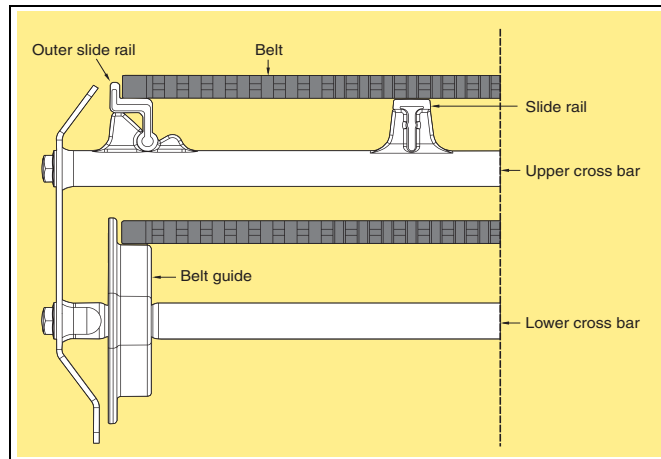

## Technical characteristics

Belt width	456 mm	
Modular belt weight (Acetal)		
Radius flush grid (R2.2)	3,43 kg/m	
Radius flush grid (R1.7)	3,85 kg/m	
Flat top belt	3,22 kg/m	
Modular belt height		
Radius flush grid	13 mm	PO
Flat top belt	10 mm	
Belt pitch	25,4 mm	
Max. permissible belt tension without bends	1200N	X70X
Max. permissible belt tension through a bend	1000N/750N*	
*belt R.17 (WLTP 1A304S, WLTP 1A304 BS, WLTP 1A304WS, WLTP 1A304 WBS)		X85X

## Tools and accessories

The belt should be pretensioned with a return slack of about 25 mm. Too much belt slack is a safety risk as the belt can hang below the side of the conveyor beam. A belt tensioner tool (51 18803) is available in order to facilitate installation of the belt and minimize the amount of slack in the return belt.

## Ordering information

The belt is delivered in assembled 1 m lengths. To calculate the total length required, remember to add for belt consumed by the idler and drive units.

X180X  
X300X  
WL 222X  
WL 273X  
WL 374X  
WL 526X  
WL 678X  
CSX  
GRX  
FSTX  
TR  
APX  
IDX

# Modular belts

## Radius flush grid belt (R2.2), Dry



Plain belt

Belt material Acetal (POM)  
Pin material Polyamide (PA),  
brown  
Length 1 m  
456 mm wide, White  
456 mm wide, Blue

**WLTP 1A456L**  
**WLTP 1A456L B**

## Flat top belt

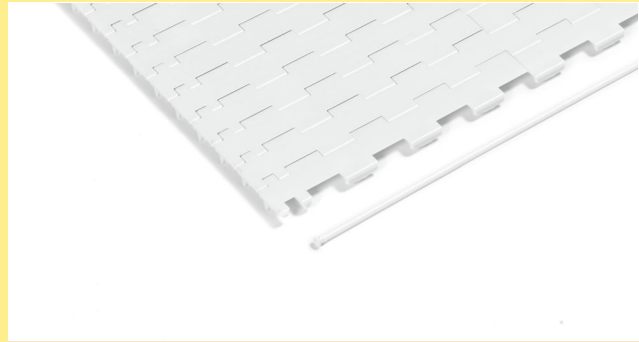

Flat top belt

Belt material Acetal (POM)  
Pin material Acetal (POM), white  
Length 1 m  
456 mm wide

**WLTP 1B456 W**

## Radius flush grid belt (R2.2), Wet



Plain belt

Belt material Acetal (POM)  
Pin material Acetal (POM),  
white  
Length 1 m  
456 mm wide, White  
456 mm wide, Blue

**WLTP 1A456L W**  
**WLTP 1A456L WB**

## Radius flush grid belt (R1.7), Dry



Plain belt

Belt material Acetal (POM)  
Pin material Polyamide (PA),  
brown  
Length 1 m  
456 mm wide, White  
456 mm wide, Blue

**WLTP 1A456 S**  
**WLTP 1A456 BS**

## Belt tensioner tool for radius flush grid

Belt tensioner tool

**5118803**

## Radius flush grid belt (R1.7), Wet



### Plain belt

Belt material Acetal (POM)  
Pin material Acetal (POM),  
white  
Length 1 m  
456 mm wide, White  
456 mm wide, Blue

**WLTP 1A456 WS**  
**WLTP 1A456 WBS**

PO

X70X

X85X

X180X

X300X

WL  
222X

WL  
273X

WL  
374X

WL  
526X

WL  
678X

CSX

GRX

FSTX

TR

APX

IDX

# Conveyor Beams - Introduction

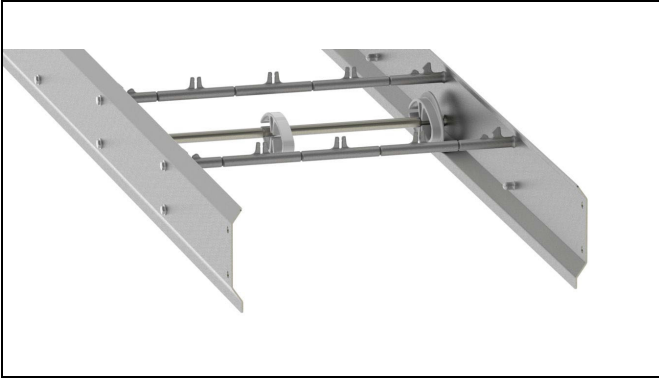

Conveyor frame structure

Components such as plain bends, etc., cannot be placed too close to an End drive unit. Therefore, the minimum permissible length for conveyor beam sections when connecting to an End drive unit is 844 mm. This ensures a sufficient amount of return belt tension directly after the drive sprocket to avoid slack close to the sprocket wheel. The return belt hanging between the first two belt guides provides this belt tension (called back tension). For more information see WLX Engineering guidelines.

Connecting brackets have to be ordered separately when joining End drives, idler ends, conveyor beams, etc.

When joining two conveyor beams, a beam spacer kit must be ordered separately.

## Frame profiles and cross bars

In order to facilitate cleaning, the top belt can be lifted up and the outer slide rails can be folded back.

For hygiene reasons, the WLX system is based on an easy-to-clean, free hanging return belt.

Elongation of the belt due to load is normally evenly distributed on the return side and along the whole conveyor, and placement of the belt guides for the return belt is critically important for proper conveyor system performance. Conveyor beams can be ordered from 142 mm up to 3000 mm and are always pre-engineered and configured according to the rules that must be followed.

Conveyor beams are normally not symmetrical, which is why they have an upstream and downstream end. An arrow label on the conveyor beam side indicates the appropriate top belt travel direction to ensure correct assembly.

## Conveyor dimensions

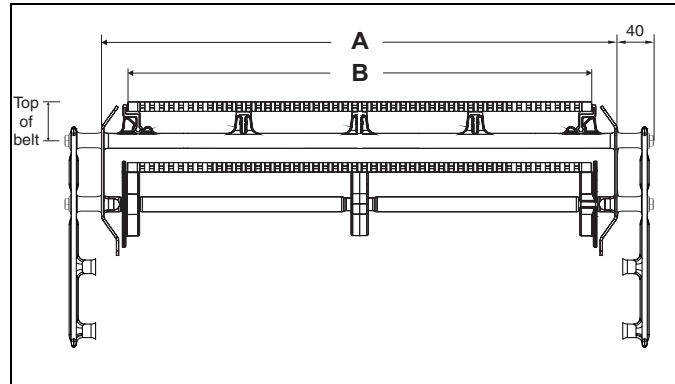

	<b>WL526X</b>
Conveyor width A	526 mm
Usable belt width B	456 mm
<b>Top of belt:</b>	
WLTP 1A	52 mm
WLTP 1B	49 mm

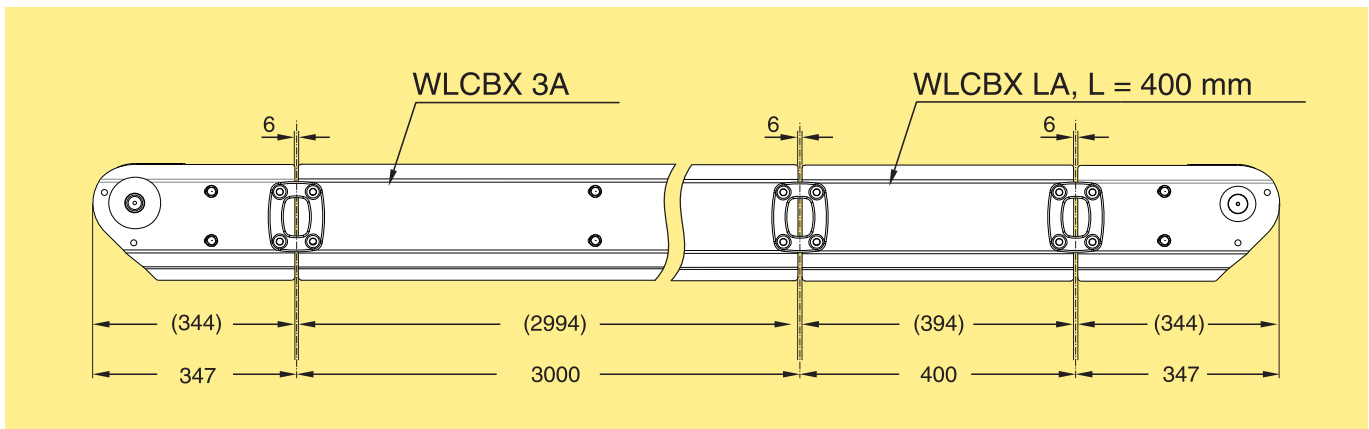

# Technical specifications

Minimum permissible conveyor beam length to be connected:

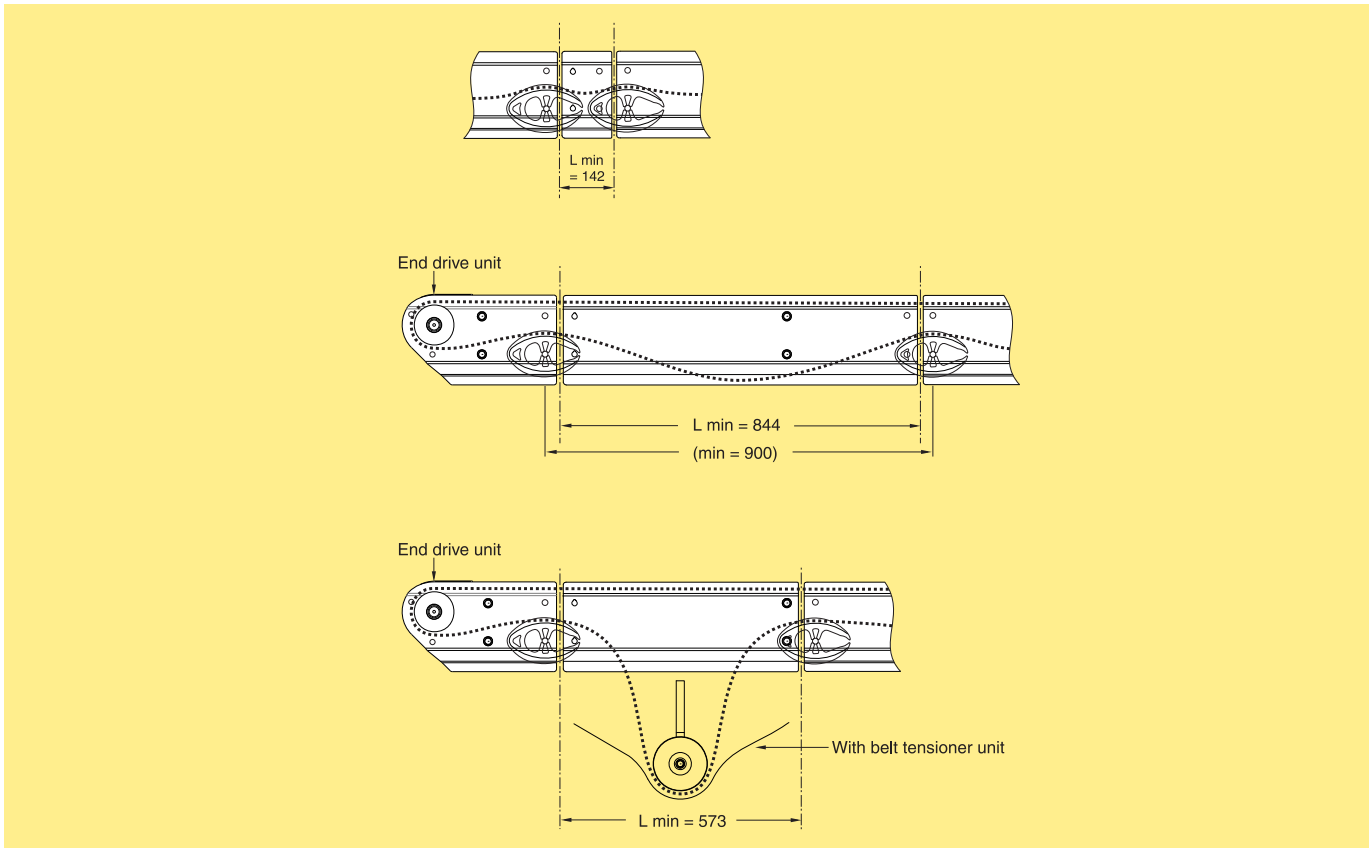

PO  
X70X  
X85X

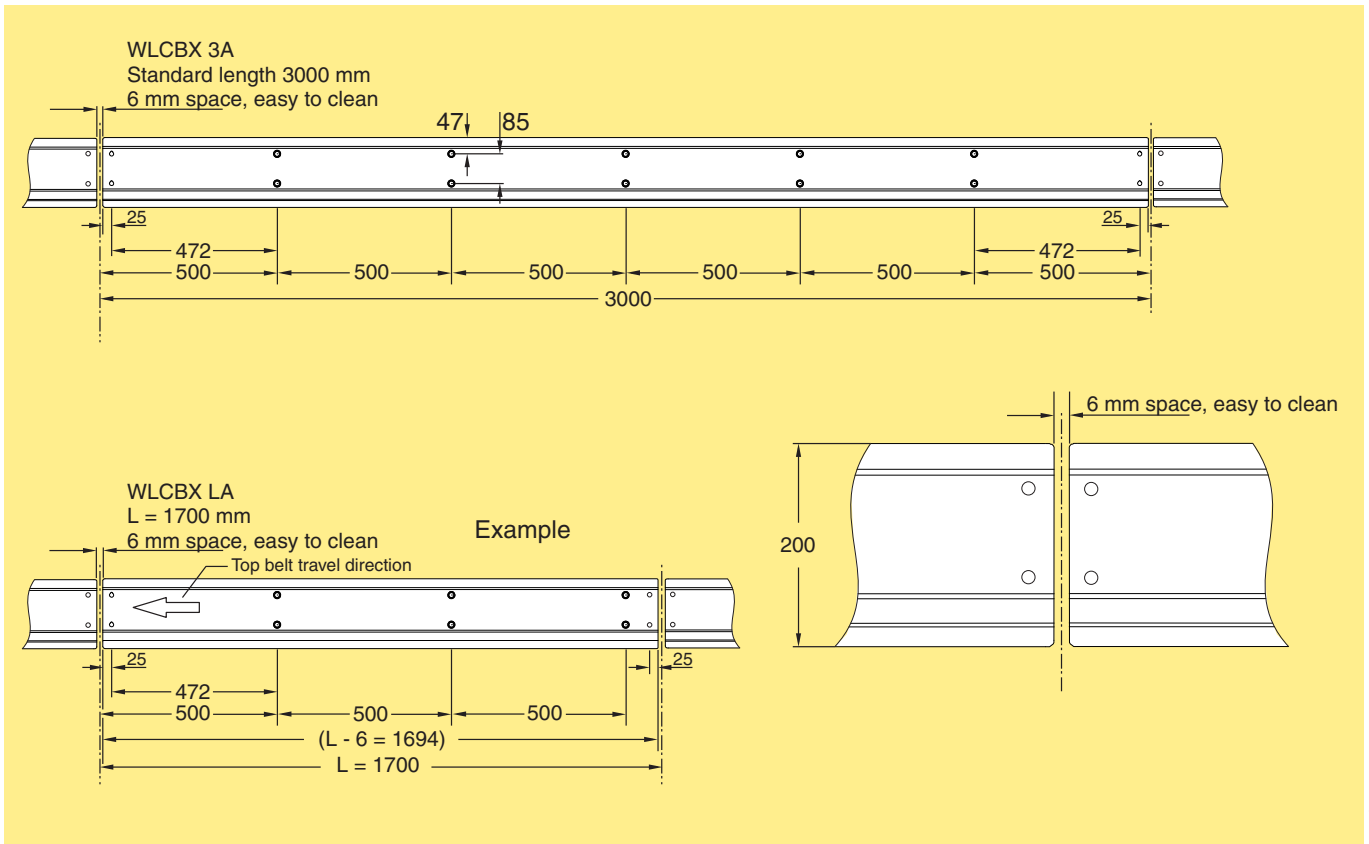

X180X  
X300X  
WL 222X  
WL 273X  
WL 374X  
WL 526X  
WL 678X  
CSX  
GRX  
FSTX  
TR  
APX  
IDX

## Lift arms for straight conveyors

In order to simplify the cleaning process FlexLink offers belt lift arms for straight conveyors.

The lift arms are assembled to the beam WLCBX LA526 C and are compatible with these belts:

- WLTP 1A456L W
- WLTP 1A456L WB

A Belt tensioner unit has to be added for proper function. See “Belt tensioner unit” on page 160.

## Use the online configurator and FlexLink Online Store

To to acquire a straight conveyor with lift arms, you'll need:

- A beam with pre-drilled holes for assembly of lift arms.
- Two extra cross bars.
- A number of lift arms. The number depends on the conveyor length.

This is calculated automatically and the configurator generates a Bill of Material (BoM). Enter the items on the BoM into FlexLink Online Store.

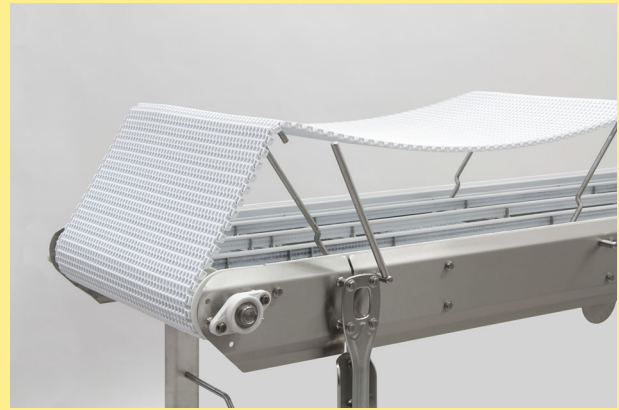

## Examples

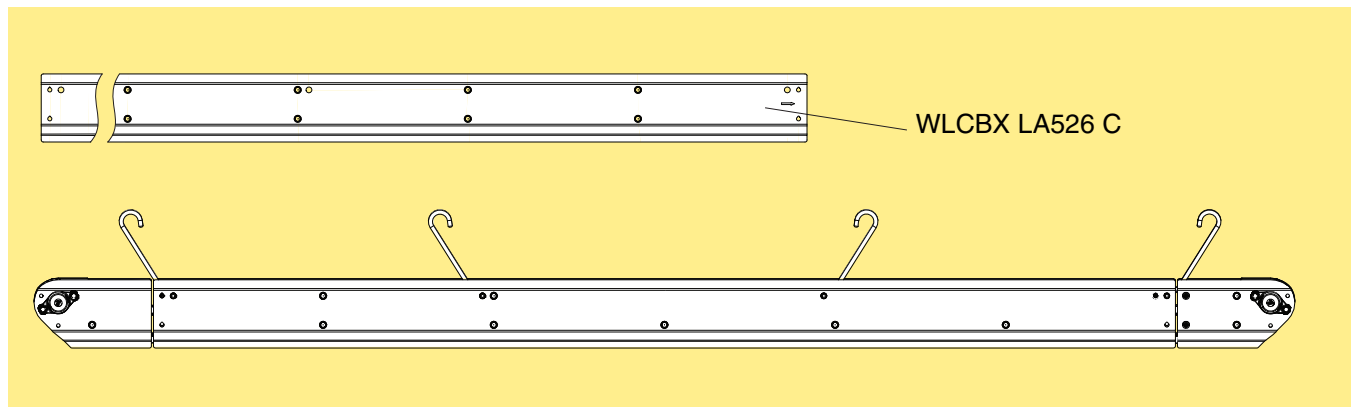

# Conveyor frame components

## Conveyor beam, Easy Clean

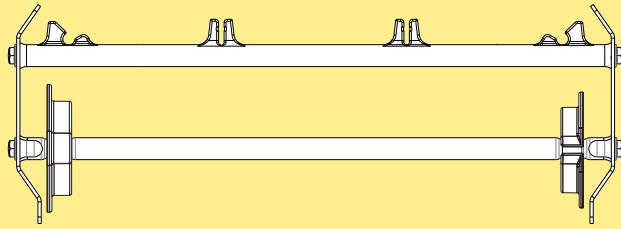

Conveyor beam, WL526X  
 Length 3 m (3000 ±1,2 mm) **WLCBX 3A526**  
 Length to order (142- 2999 mm) **WLCBX LA526**

\* Use online configurator when ordering  
 Effective track length: 2,1 m  
 Weight, incl belt: 21 kg/m

## Conveyor beam, Easy Clean for lift arm(s)

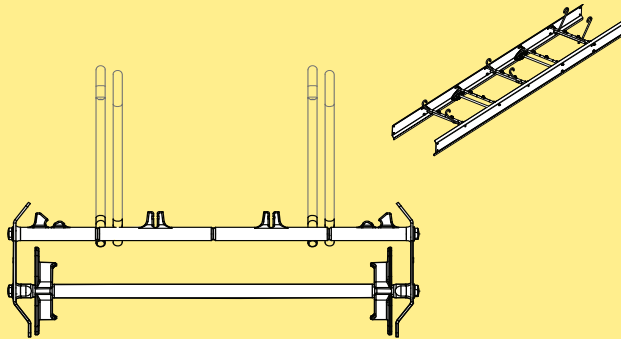

Conveyor beam, WL526C  
 Length 3 m (3000 ±1,2 mm) **WLCBX 3A526 C**  
 Length to order (142- 2999 mm) **WLCBX LA526 C**

\* Use online configurator when ordering  
 Effective track length: 2,1 m  
 Weight, incl belt: 21 kg/m

## Lift unit WL526X

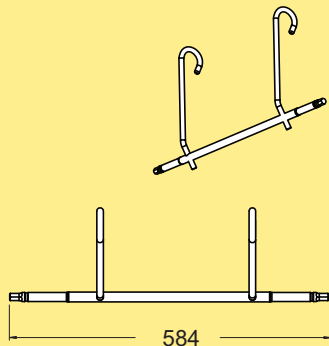

Lift unit WL526X **FLX1012352**

## Crossbar WL526X

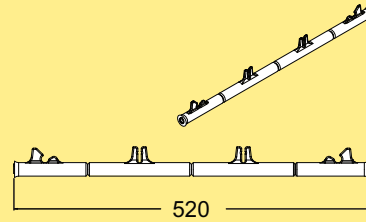

Crossbar WL526X **FLX1012351**

Including 2 pcs XCASX 10X16

## Connecting bracket kit

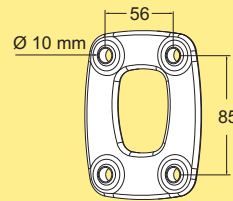

Connecting Bracket  
 For beam  
 Including 4 pcs M10 screws

**WLCJX 10X56**

## Beam support brackets

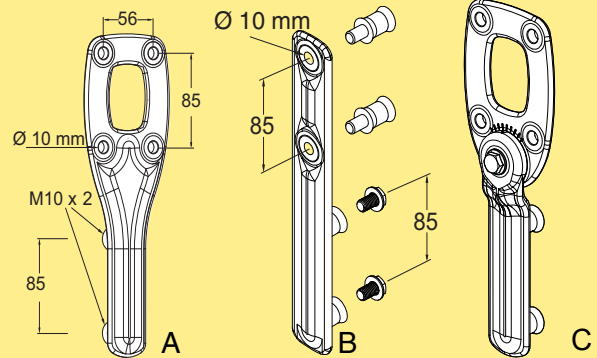

Beam support bracket (A)  
 Including 6 pcs M10 screws

**WLCSX 10X56**

Beam support bracket (B)  
 Including 2 pcs M10 screws and  
 2 pcs spacer WLRDX M10X25

**WLCSX 10**

Beam support bracket (C)  
 Adjustable ±40°

**WLCSX  
 10X56V40**

PO  
 X70X  
 X85X  
 X180X  
 X300X  
 WL  
 222X  
 WL  
 273X  
 WL  
 374X  
 WL  
 526X  
 WL  
 678X  
 CSX  
 GRX  
 FSTX  
 TR  
 APX  
 IDX

### Beam spacer Kit for WL526

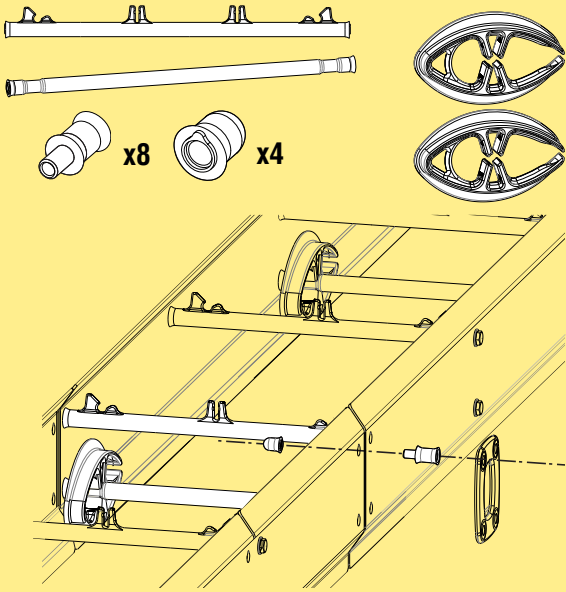

Beam spacer kit

**WLCEX A526**

Recommended Torx tool for fasten spacer  
Size T30

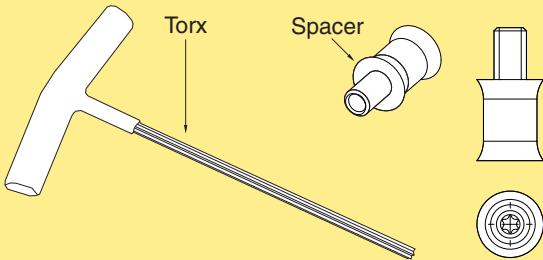

### Slide rail

#### Slide rail

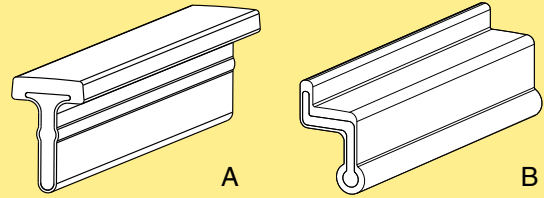

Slide rail, length 3 m  
Slide rail (A)  
Outer slide rail (B)

**WLCRX 3  
WLCRX 3 B**

#### Connecting Strip

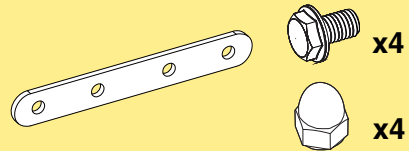

Connecting strip kit  
Contains 10 pcs.

**WLAHX 100**

#### Drill fixture for connecting strip

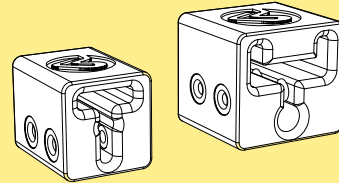

Contains drill fixtures for both  
WLCRX 3 and WLCRX 3B

**5118922**

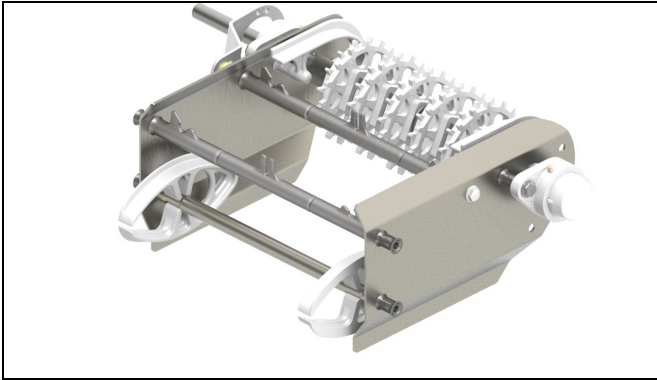

End drive unit

## End drive units

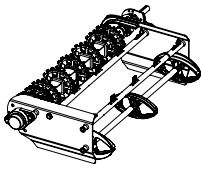
Size	Direct drive, no slip clutch
Drive unit types	 <p>F, V</p>

## Drive unit types

A soft motor start is recommended for use with high-speed and long conveyors. This is because these types of modular belts are quite heavy, and the free hanging return belt can begin to oscillate momentarily during startup.

A grease nipple is included in all flange bearings. The bearings are initially filled with FDA-approved, food-grade grease (NSF H1).

End drive units including SEW motors IP 65, can be ordered with food-grade oil and stainless steel hollow shafts in the web-based configurator.

## Motor specifications

Motors are available for 230/400 V, 50 Hz and 230/460 V, 60 Hz. Variable speed motors are SEW Movimot, 380–500 V. Note that variable speed motors include a control box that adds 120 mm to the width of the motor.

IP55 available with standard oil.

IP65 available with food grade oil.

## Technical specifications

Maximal speed..... 40 m/min  
 Number of teeth on sprocket wheel... 16

## Belt tensioner unit

A belt tensioner unit should always be placed near the End drive unit and its use is recommended:

- for long conveyors >20 meters
- for long conveyors >15 m and a speed of >30 m/min
- for conveyors with frequent starts/stops, especially if the load is high
- if an End drive unit needs to be placed close to a plain bend
- if an End drive unit needs to be placed on the lower part next to a conveyor slope section
- for short conveyors where the belt slack length is insufficient to lift the belt for cleaning

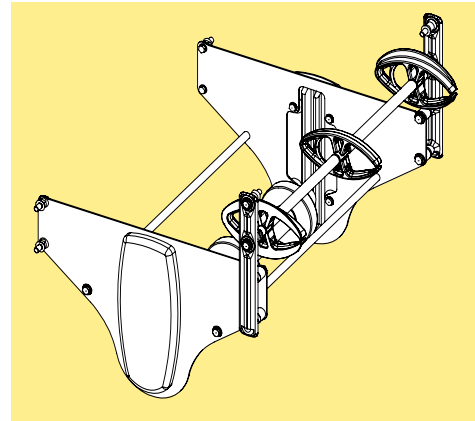

## Ordering information

Drive units with motors must be specified using the web-based configurator. The configurator provides detailed information and step-by-step guidance in the specification process. A product code string is generated, containing the specification details. See next page for examples of code strings.

Drive units *without* motors can be ordered using the designations in the catalogue.

- Connecting brackets have to be ordered separately.
- Slide rail must be ordered separately.

## Dimension

Note that dimensions relating to drive unit motors depend on the motor specified during the configuration.

PO  
 X70X  
 X85X  
 X180X  
 X300X  
 WL  
 222X  
 WL  
 273X  
 WL  
 374X  
 WL  
 526X  
 WL  
 678X  
 CSX  
 GRX  
 FSTX  
 TR  
 APX  
 IDX

## Drive units – configuration strings

Below are two examples of text strings obtained from the configurator with explanations.

### Drive unit with fixed speed motor

Item no	A	B	D	E	G	H	I
	HNP	- L	- V4	- SA37	- 50/230	- 0,18kW	- TF

### Drive unit with variable speed motor

Item no	A	B	D	E	F	G	J	K
	HPV	- L	- V6-15	SA37	- MM03	- 50/380-500	- C	- P

#### Item no - Drive type

WLEBX: End drive

TF: Thermal protection type TF

TH: Thermal protection type TH

(position is omitted for variable speed motors)

#### A – 0-Unit

HNP: Direct drive, no slip clutch

...V: Variable speed

#### J – Hybrid cable

No: No hybrid cable

C: Hybrid cable included in SEW Movimot

(position is omitted for fixed speed motors)

#### B – Motor position

L: Left

R: Right

#### K – Fieldbus

No: No fieldbus

P: Profibus fieldbus, maintenance switch

D: DeviceNet fieldbus, maintenance switch

(position is omitted for fixed speed motors)

#### D – Speed

V...: Fixed speed... m/min

V...-...: Variable speed range...-... m/min

#### E – Gearbox

SA37: SEW motor type SA37

WA30: SEW gear box type WA30

#### F – Movimot size

MM03: SEW Movimot type, 0,37 kW

MM05: SEW Movimot type, 0,55 kW

MM07: SEW Movimot type, 0,75 kW

(position is omitted for fixed speed motors)

#### G – Electrical environment

50/230: 50 Hz, 230 V

50/400: 50 Hz, 400 V

60/230: 60 Hz, 230 V

60/460: 60 Hz, 460 V

50/380-500: SEW Movimot variable speed motor

#### H – Motor power

... kW: Motor power, kW

(position is omitted for variable speed motors

see position F)

#### I – Thermal protection

No: No thermal protection

## End drive unit Easy Clean, Radius flush grid 526

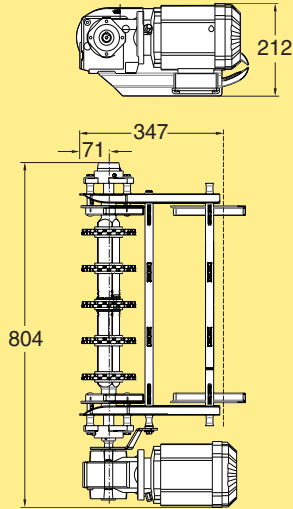

End drive unit  
 Fixed/variable speed\* **WLEBX A526**  
 Without motor:  
 Transmission on left side **WLEBX0A526NLP**  
 Transmission on right side **WLEBX0A526NRP**

\* Use online configurator when ordering  
 Effective track length: 0,8 m  
 Weight, incl belt: 20 kg

## End drive unit S, Radius flush grid 526

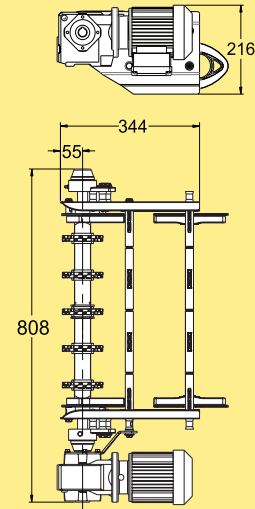

End drive unit  
 Fixed/variable speed\* **WLEBX A526 S**  
 Without motor:  
 Transmission on left side **WLEBX0A526NLP S**  
 Transmission on right side **WLEBX0A526NRP S**

\* Use online configurator when ordering  
 Effective track length: 0,75 m  
 Weight, incl belt: 19,2 kg

## End drive unit Easy Clean, Flat top 526

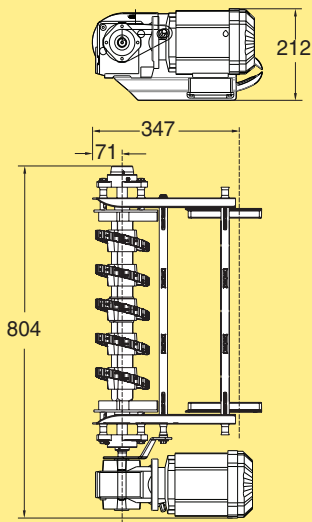

End drive unit  
 Fixed/variable speed\* **WLEBX B526**  
 Without motor:  
 Transmission on left side **WLEBX0B526NLP**  
 Transmission on right side **WLEBX0B526NRP**

\* Use online configurator when ordering  
 Effective track length: 0,80 m  
 Weight, incl belt: 20 kg

## End drive unit J, Radius flush grid 526

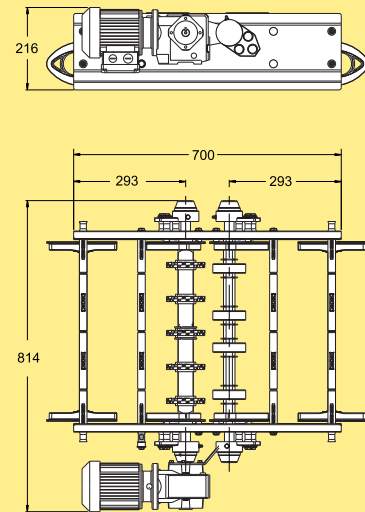

End drive unit  
 Fixed/variable speed\* **WLEBX A526 J**  
 Without motor:  
 Transmission on left side **WLEBX0A526NLPJ**  
 Transmission on right side **WLEBX0A526NRPJ**

\* Use online configurator when ordering  
 Effective track length: 1,5 m  
 Weight, incl belt: 33,0 kg

PO  
 X70X  
 X85X  
 X180X  
 X300X  
 WL 222X  
 WL 273X  
 WL 374X  
 WL 526X  
 WL 678X  
 CSX  
 GRX  
 FSTX  
 TR  
 APX  
 IDX

## Belt tensioner unit

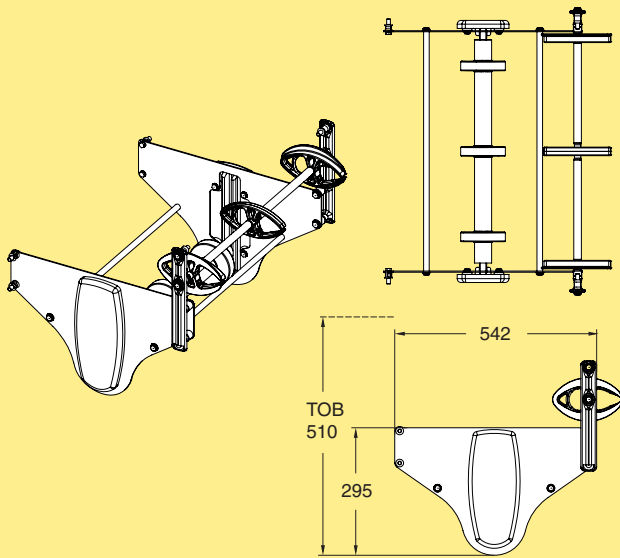

Belt tensioner for:  
WL526X

**5118890**

Required extra belt length

**0,55 m**

*Weight, incl belt: 19 kg*

# Idler end units – Introduction

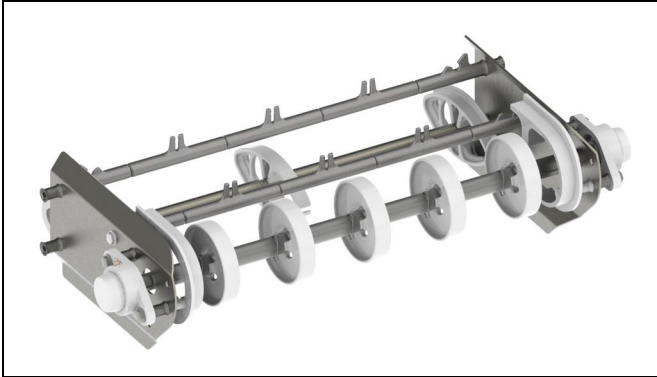

Idler end unit (generic picture)

## Chain guidance at end of conveyor

The idler end unit is used to guide the chain from the return side of the conveyor up to the top side with a minimum of friction. The chain is guided by two or more idler wheels on a common, rotating shaft supported by ball bearings.

## Ordering information

- Connecting strips are included with the idler end units.
- Slide rail must be ordered separately.

## Idler units

### Idler end unit, WL526

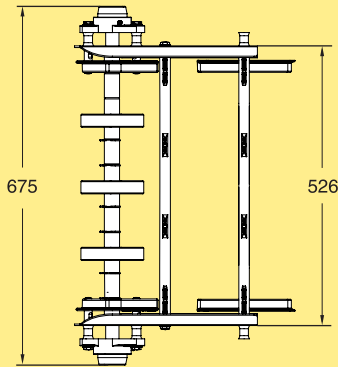
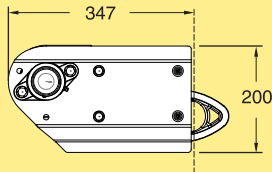

Idler end unit (For conveyors with plain bends)

**WLEJX 300A526**

Idler end unit (Only for straight conveyors)

**WLEJX 300B526**

\* Use online configurator when ordering  
Effective track length: 0,80 m  
Weight, incl belt: 18 kg

### Idler end unit, WL526 S

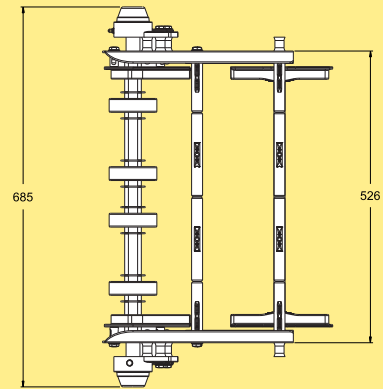
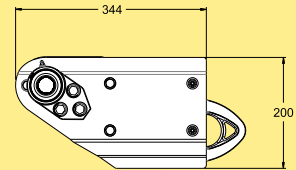

Idler end unit

**WLEJX 300A526 S**

\* Use online configurator when ordering  
Effective track length: 0,75 m  
Weight, incl belt: 15,4 kg

PO  
X70X  
X85X  
X180X  
X300X  
WL  
222X  
WL  
273X  
WL  
374X  
WL  
526X  
WL  
678X  
CSX  
GRX  
FSTX  
TR  
APX  
IDX

## Additional features

CIP (Clean-in-Place) unit, engineered for thorough modular belt cleaning to ensure hygiene and minimize contamination.



### CIP washing unit, WL526X, flat top belt

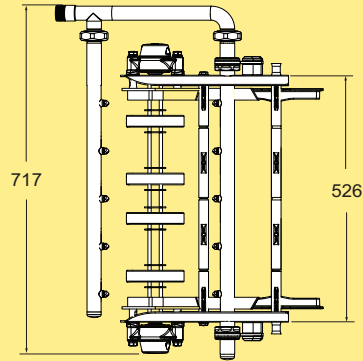
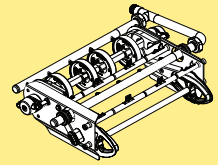
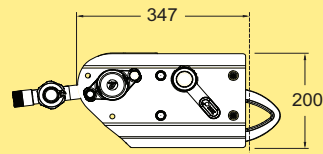

CIP washing unit for flat top belt **WLNWX B526 CIP**

### CIP washing unit, WL526X, plain belt

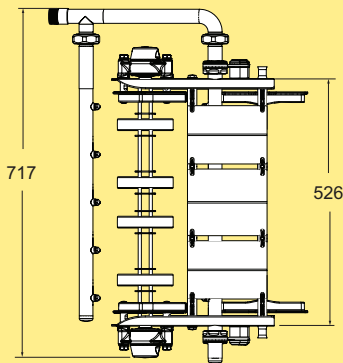
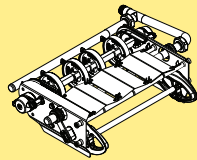
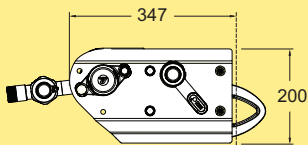

CIP washing unit for plain belt **WLNWX A526 CIP**

# Plain Bends - Introduction

When using radius flush grid belts in plain bends, the belt pull force will be concentrated on the outer part of the belt. A certain straight section is needed before and after the bend in order to transfer the load between the outer belt section and evenly distribute it to the straight belt section. This is critical before entering another plain bend, end drive unit, etc. This required straight section is always integrated in the plain bend itself (300 mm for WL374X, 450 mm for WL526X, and 600 mm for WL678X).

Plain bend placement, as for all other Flexlink conveyors, should always be considered. A plain bend placed too far downstream on a conveyor generates unnecessary belt pull. Also, placement of a plain bend too close to an end drive unit can lead to an unnecessary slack increase and a separate slack unit must be added. Always use the Flexlink calculation tool (FLCT) to calculate the resulting pull forces.

## Plain bend, Easy Clean 45°

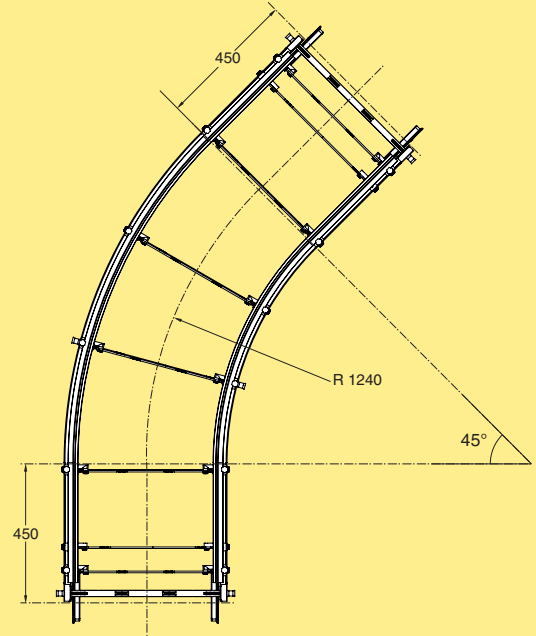

Plain bend, 45°±1°  
R=1240±10 mm

**WLBPX 45A526**

\* Use online configurator when ordering  
Effective track length: 4,2 m  
Weight, incl belt: 54 kg

PO

X70X

X85X

X180X

X300X

WL  
222X

WL  
273X

WL  
374X

WL  
526X

WL  
678X

CSX

GRX

FSTX

TR

APX

IDX

## Plain bend, Easy Clean 30°

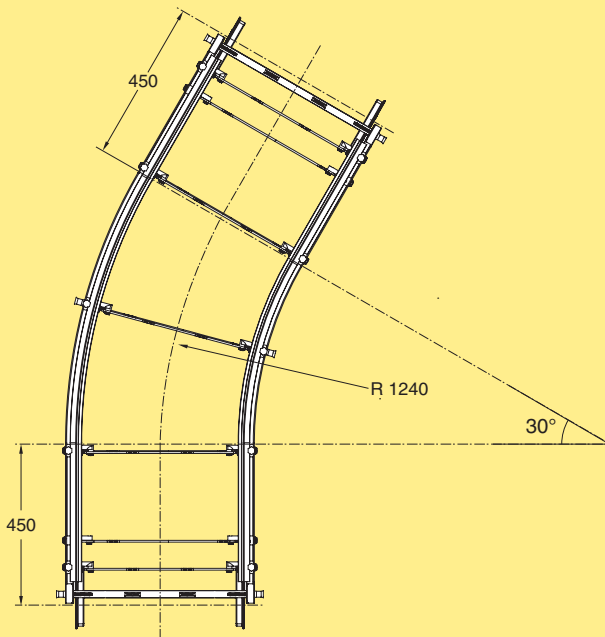

Plain bend, 30°±1°  
R=1240±10 mm

**WLBPX 30A526**

\* Use online configurator when ordering  
Effective track length: 3,4 m  
Weight, incl belt: 46 kg

## Plain bend, Easy Clean 60°

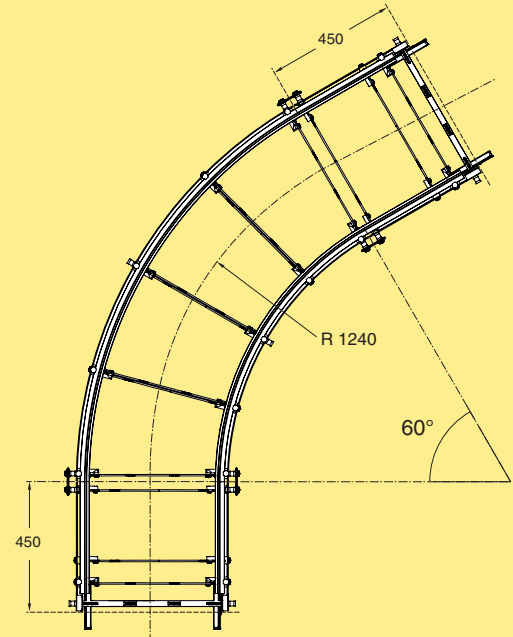

Plain bend, 60°±1°  
R=1240±10 mm

**WLBPX 60A526**

\* Use online configurator when ordering  
Effective track length: 4,9 m  
Weight, incl belt: 64 kg

**Plain bend, Easy Clean 90°**

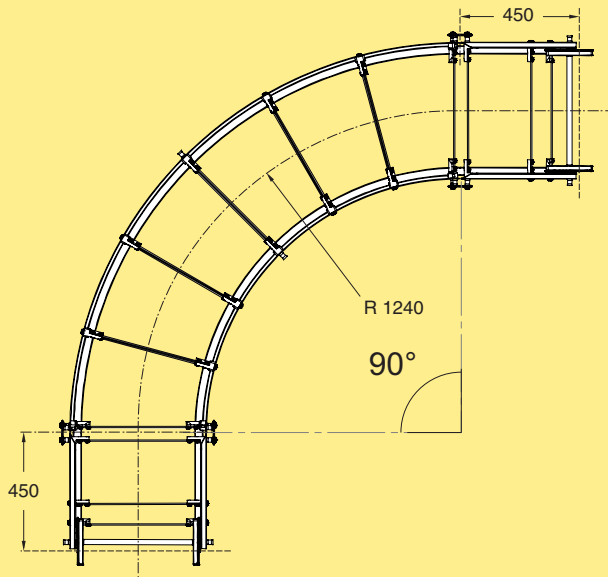

Plain bend, 90°±1°

R=1240±10 mm

**WLBPX 90A526**

*\* Use online configurator when ordering*  
 Effective track length: 6,5 m  
 Weight, incl belt: 79 kg

**Plain bend, Easy Clean 45° R1,7**

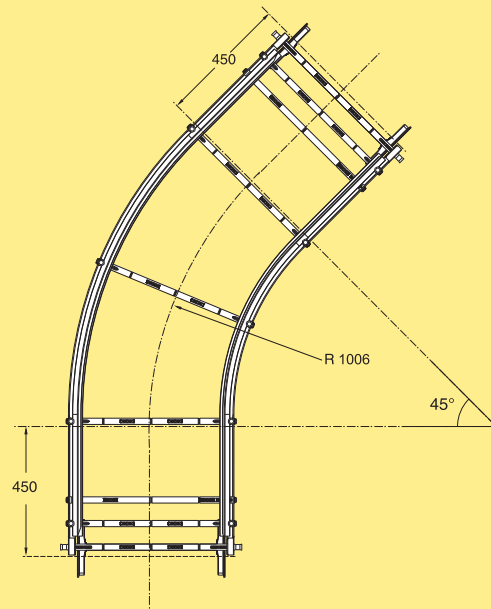

Plain bend, 45°±1°

R=1006±10 mm

**WLBPX 45A526 S**

*\* Use online configurator when ordering*  
 Effective track length: 3,38 m  
 Weight, incl belt: 49,3 kg

**Plain bend, Easy Clean 30° R1,7**

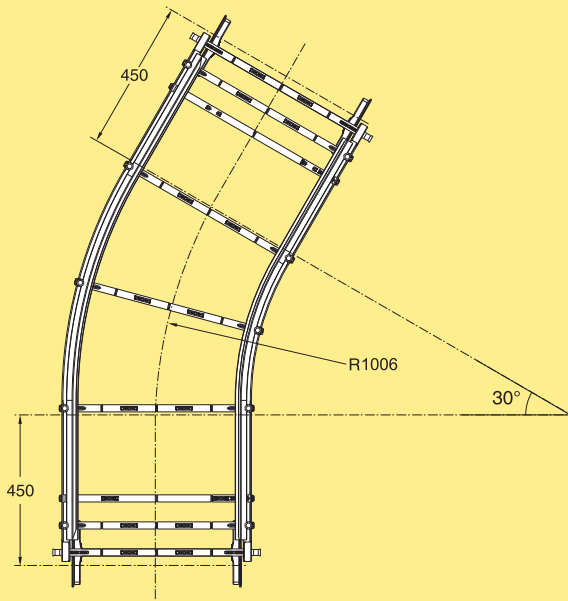

Plain bend, 30°±1°

R=1006±10 mm

**WLBPX 30A526 S**

*\* Use online configurator when ordering*  
 Effective track length: 2,85 m  
 Weight, incl belt: 45,1 kg

**Plain bend, Easy Clean 60° R1,7**

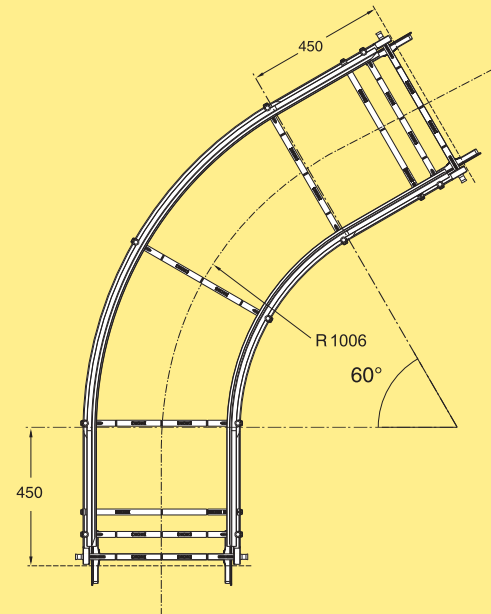

Plain bend, 60°±1°

R=1006±10 mm

**WLBPX 60A526 S**

*\* Use online configurator when ordering*  
 Effective track length: 3,91 m  
 Weight, incl belt: 53,5 kg

**Plain bend, Easy Clean 90° R1,7**

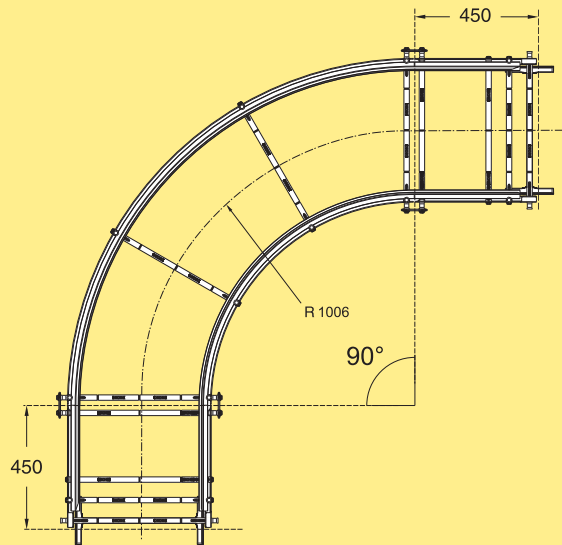

Plain bend, 90°±1°

R=1006±10 mm

**WLBPX 90A526 S**

\* Use online configurator when ordering  
 Effective track length: 4,96 m  
 Weight, incl belt: 67 kg

**Plain bend, Easy Clean 180° R1,7**

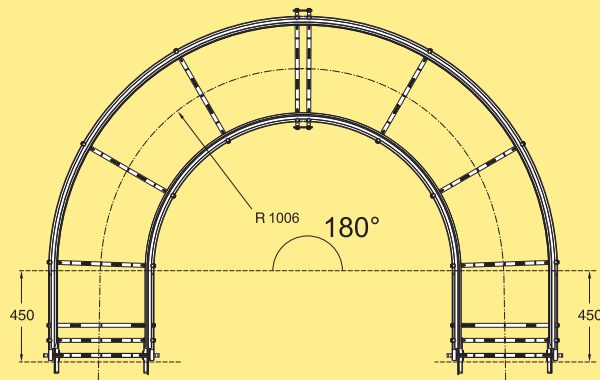

Plain bend, 180°±2°

R=1006±10 mm

**WLBPX 180A526 S**

\* Use online configurator when ordering  
 Effective track length: 8,12 m  
 Weight, incl belt: 102,2 kg

**Vertical bends**

**Vertical bend, Easy Clean, 5° (neg.)**

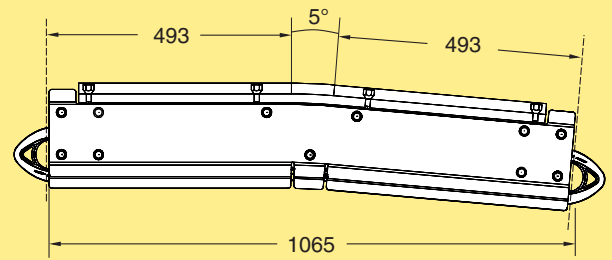

Vertical bend 5°, neg

**WLBVX 5A526N**

\* Use online configurator when ordering  
 Effective track length: 2,1 m  
 Weight, incl belt: 32 kg

**Vertical bend, Easy Clean, 5° (pos.)**

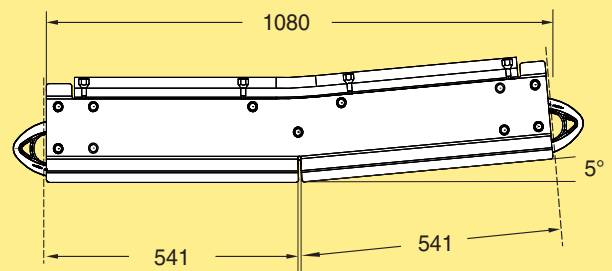

Vertical bend 5°, pos

**WLBVX 5A526P**

\* Use online configurator when ordering  
 Effective track length: 2,1 m  
 Weight, incl belt: 32 kg

- PO
- X70X
- X85X
- X180X
- X300X
- WL 222X
- WL 273X
- WL 374X
- WL 526X
- WL 678X
- CSX
- GRX
- FSTX
- TR
- APX
- IDX

# Support System Modules - Introduction

## Conveyor supports

Support modules must be specified using the web-based configurator. There, a product code string is generated that contains the specification details (E.g., WLUFX S01-WL374X-900).

### Support module, single leg

Top of belt  
660 - 1500

Connecting brackets

Adjustable foot  
± 33

Support module, single leg **WLUFX S04**

**Support module, single leg WLUFX S04**

Parameter	Option
Top of belt:	660-1500 mm
Foot type:	XCFSX 16x80 H XCFSX 16x80 HA XCFSX 16x80 XCFSX 16x80 A
Bracket type:	WLCSX 10X56 WLCSX 10

### Support module, type H

Top of belt  
660 - 1500

Connecting brackets

Adjustable foot  
± 33

Support module type H **WLUFX S01**

**Support module type H, WLUFX S01**

Parameter	Option
Platform	WL222X WL273X WL374X WL526X WL678X
Top of belt:	660-1500 mm
Foot type:	XCFSX 16x80 H XCFSX 16x80 HA XCFSX 16x80 XCFSX 16x80 A
Bracket type:	WLCSX 10X56 WLCSX 10 WLCSX 10X56V40

### Foot holder for adjustable foot

M10 (x2)

85

46

M16  
Depth 100

31

Foot holder  
Including 2 pcs M10 screws **XCFCX 16x100**

### Adjustable foot

M16

Ø 80

243

37 Max

66 Min

Ø 15 mm

Adjustable foot

M16	<b>XCFSX 16x80</b>
M16, Anchoring	<b>XCFSX 16x80 A</b>
M16, EHEDG/3A	<b>XCFSX 16x80 H</b>
M16, EHEDG/3A, Anchoring	<b>XCFSX 16x80 HA</b>