

# Modular belt conveyor WL222X

## Contents

System information.....	95	Drive units – configuration strings .....	105
Conveyor sections.....	97	End drive units .....	106
Modular Belts - Introduction .....	98	Idler end units – Introduction.....	107
Modular belts .....	99	Idler units.....	107
Conveyor Beams - Introduction.....	100	Additional features .....	107
Conveyor frame components .....	102	Plain Bends - Introduction.....	108
Slide rail .....	103	Support System Modules - Introduction .....	110
End Drive Units - Introduction.....	104		

## System information



PO  
X70X  
X85X  
X180X  
X300X  
WL  
222X

### System overview

FlexLink's newly developed stainless steel conveyor is designed to fit into demanding primary and secondary packaging applications. It addresses important aspects of today's packing processes, such as being easy to clean, smooth handling of products, safe for operators, robust design, long life, and easy to maintain with a low cost of ownership.

The modularized and standardized design ensures fast set up, and facilitates rapid future extensions and changes.

### Separation of larger surfaces

To simplify cleaning and to ensure consistent results, larger surfaces have been separated to improve access between them for cleaning and inspection of results. This separation also improves drainage and speeds up the drying process after cleaning. Also, the bearings are separated 25 mm from the framework with spacers to prevent contamination.



WL  
273X

WL  
374X

WL  
526X

WL  
678X



CSX

GRX

FSTX

TR

APX

IDX

### Small contact surfaces

To make the cleaning process faster and consistent, the small contact surfaces within the frame have been designed in order to eliminate hard-to-reach areas.



### No open threads

Due to the difficulties of keeping open threads clean, all threads in the conveyor are covered from the top down to the floor.



### Reduction of sharp corners

To achieve efficient and consistent cleaning results, it is important to avoid sharp corners that are hard to clean. Both inside and outside of the framework, smooth edges have been added at perpendicular contact surfaces to aid operators when cleaning the conveyor in both wet and dry applications.

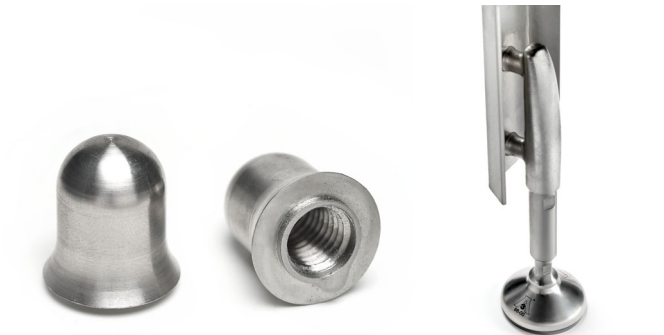

### No flat surfaces for better drainage

In wash-down environments, it is important to have proper drainage of water and other liquids. The WLX design has been optimized in this regard by selecting different manufacturing processes to create shapes that enable efficient drainage. This will also have an important impact on its ability to be cleaned in dry environments in both primary and secondary packaging lines.



### Belt width 152/203/304/456/608 mm

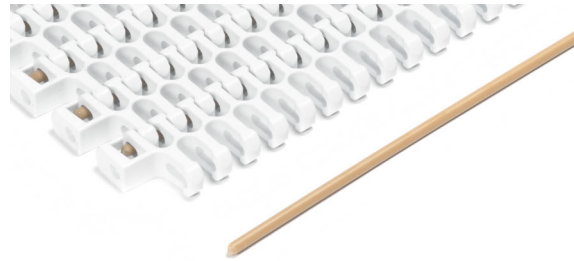

### Technical specifications

Maximum speed:	40 m/min
Maximum conveyor length:	20 m
Max single item weight:	up to 30 kg
Total load on a conveyor:	300 kg
Max product weight per belt pitch:	1,5 kg/slide rail
Max permissible pull force (with bends):	500 N
Max permissible pull force (without bends):	1200 N

# Conveyor sections

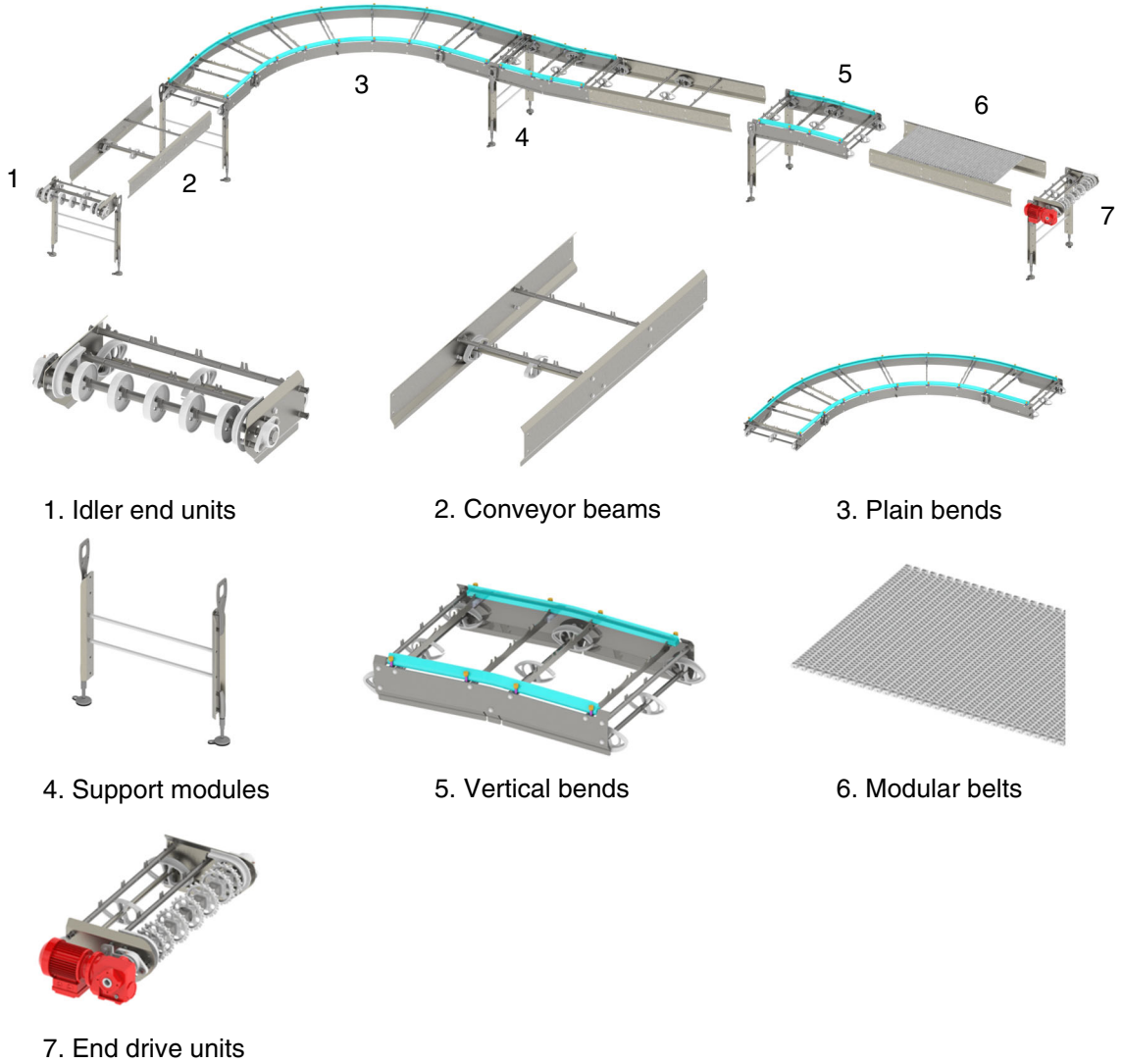

The modular plastic belt conveyor in five widths – 222, 273, 374, 526 and 678 mm – can be built as straight sections or in S, U or L-shape with 30, 45, 60, 90° (180° only for 222 and 273) horizontal bend, or combinations thereof. Vertical bends are available in 5° (3° only for 222 and 273) positive or negative.

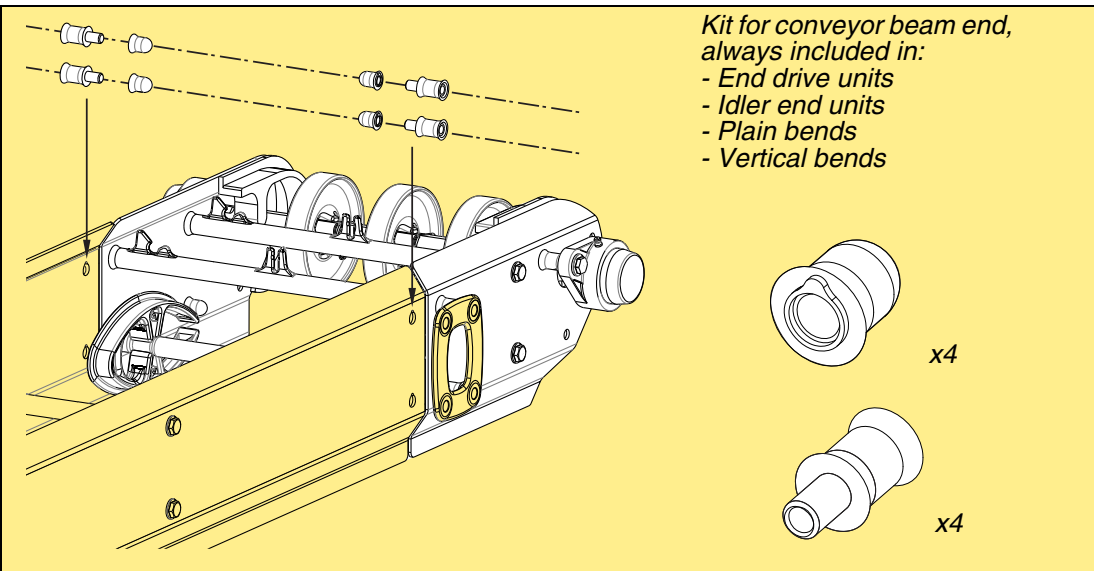

- PO
- X70X
- X85X
- X180X
- X300X
- WL 222X
- WL 273X
- WL 374X
- WL 526X
- WL 678X
- CSX
- GRX
- FSTX
- TR
- APX
- IDX

# Modular Belts - Introduction

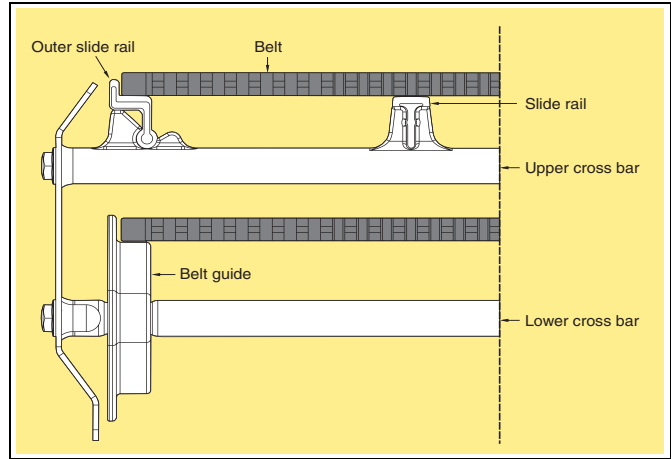
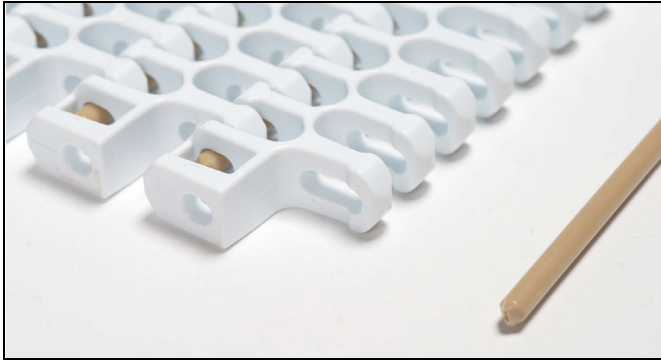

## Modular belt, Radius flush grid, curve-running

The belt consists of plastic hinged links connected by plastic rods. The wide belts are woven together by links that are 102 mm, 124 mm, and 180 mm wide. The assembled belt forms a wide, flat, and tight conveyor surface. Five standard widths of belt can be delivered: 152 mm, 203 mm, 304 mm, 456 mm, and 608 mm.

Standard belt colour is white but blue belts can also be ordered.

Belts with polyamide pins are available for dry or semi-wet applications. In constant wet applications, belts with acetal pins must be used. This is due to the fact that polyamide pins will absorb water and swell in wet applications, and acetal pins will squeak in dry environments.

Travel direction of the belts:

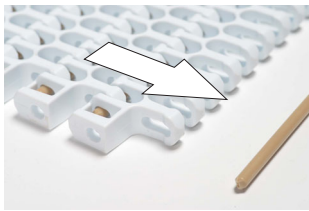

Radius flush grid

## Technical characteristics

Belt width	152 mm
Modular belt weight (Acetal) Radius flush grid	1,15 kg/m
Modular belt height Radius flush grid	13 mm
Belt pitch	25,4 mm
Max. permissible belt tension without bends	1200 N
Max permissible belt tension through a bend: Belt width 152	500 N

## Tools and accessories

The belt should be pretensioned with a return slack of about 25 mm. Too much belt slack is a safety risk as the belt can hang below the side of the conveyor beam. A belt tensioner tool (5118803) is available in order to facilitate installation of the belt and minimize the amount of slack in the return belt.

## Ordering information

The belt is delivered in assembled 1 m lengths. To calculate the total length required, remember to add for belt consumed by the idler and drive units.



reddot award 2016  
honourable mention industrial design

WLX, the modular wide belt conveyors with stainless steel beam, received the Honourable Mention provided by the Red Dot jurors for a particularly well-executed aspect of design work. Products which impress with a well-thought-out detail solution are awarded this honourable mention.



FlexLink supply a 3-A qualified WLX conveyor. For more information, contact your local sales office.

# Modular belts

## Radius flush grid belt, Wet



Plain belt  
 Belt material Acetal (POM)  
 Pin material Acetal (POM),  
 white  
 Length 1 m  
 152 mm wide, White  
 152 mm wide, Blue

**WLTP 1A152L W**  
**WLTP 1A152L WB**

## Radius flush grid belt, Dry



Plain belt  
 Belt material Acetal (POM)  
 Pin material Polyamide (PA),  
 brown  
 Length 1 m  
 152 mm wide, White  
 152 mm wide, Blue

**WLTP 1A152L**  
**WLTP 1A152L B**

PO

X70X

X85X

X180X

X300X

WL  
 222X

WL  
 273X

WL  
 374X

WL  
 526X

WL  
 678X

CSX

GRX

FSTX

TR

APX

IDX

## Belt tensioner tool for radius flush grid

Belt tensioner tool

**5118803**

# Conveyor Beams - Introduction

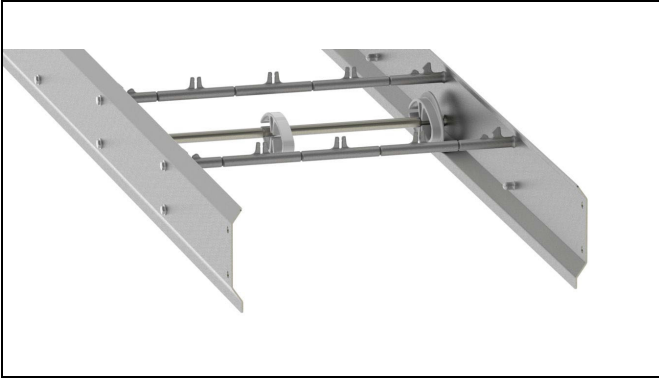

Conveyor frame structure

when connecting to an End drive unit is 844 mm. This ensures a sufficient amount of return belt tension directly after the drive sprocket to avoid slack close to the sprocket wheel. The return belt hanging between the first two belt guides provides this belt tension (called back tension). For more information see WLX Engineering guidelines.

Connecting brackets have to be ordered separately when joining End drives, idler ends, conveyor beams, etc.

When joining two conveyor beams, a beam spacer kit must be ordered separately.

## Conveyor dimensions

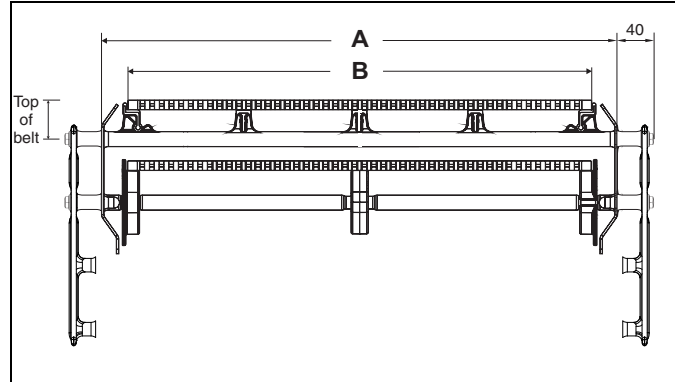

	<b>WL222X</b>
Conveyor width A	222 mm
Usable belt width B	152 mm
<b>Top of belt:</b>	
WLTP 1A	52 mm
WLTP 1B	49 mm

## Frame profiles and cross bars

In order to facilitate cleaning, the top belt can be lifted up and the outer slide rails can be folded back.

For hygiene reasons, the WLX system is based on an easy-to-clean, free hanging return belt.

Elongation of the belt due to load is normally evenly distributed on the return side and along the whole conveyor, and placement of the belt guides for the return belt is critically important for proper conveyor system performance. Conveyor beams can be ordered from 142 mm up to 3000 mm and are always pre-engineered and configured according to the rules that must be followed.

Conveyor beams are normally not symmetrical, which is why they have an upstream and downstream end. An arrow label on the conveyor beam side indicates the appropriate top belt travel direction to ensure correct assembly.

Components such as plain bends, etc., cannot be placed too close to an End drive unit. Therefore, the minimum permissible length for conveyor beam sections

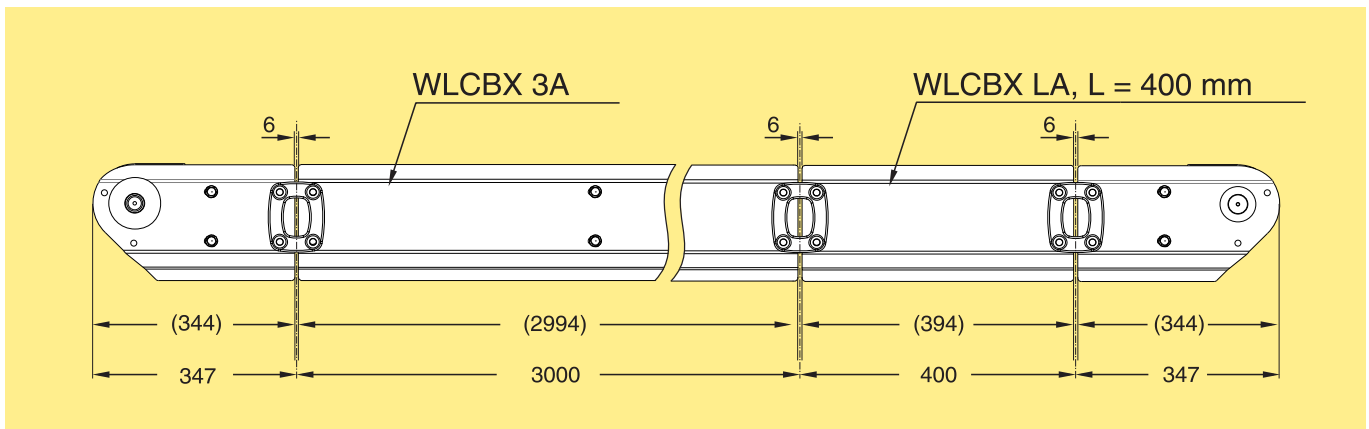

# Technical specifications

Minimum permissible conveyor beam length to be connected:

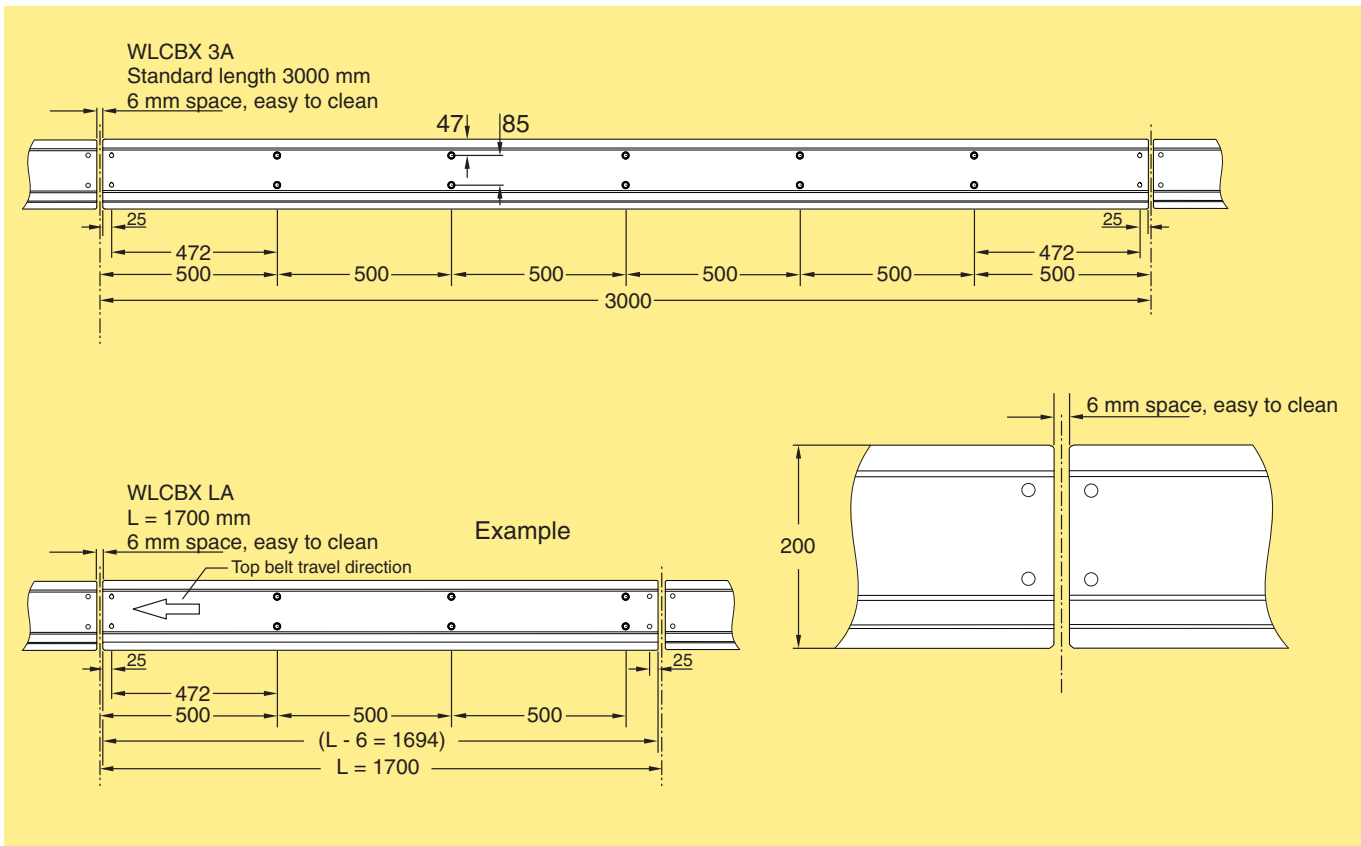
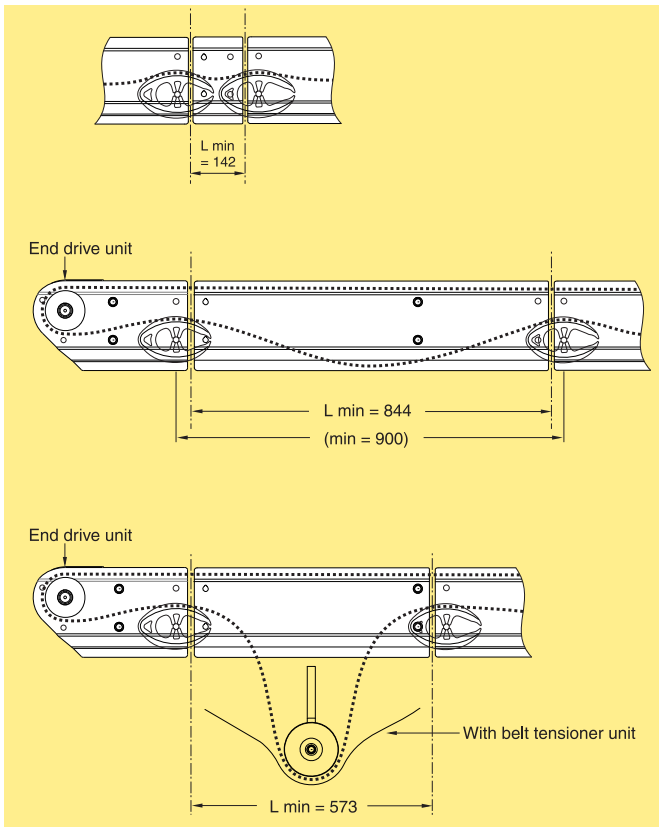

- PO
- X70X
- X85X
- X180X
- X300X
- WL 222X
- WL 273X
- WL 374X
- WL 526X
- WL 678X
- CSX
- GRX
- FSTX
- TR
- APX
- IDX

## Conveyor beam, Easy Clean

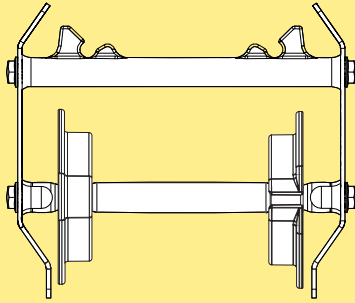

Conveyor beam, WL222X  
 Length 3 m (3000 ±1,2 mm) **WLCBX 3A222**  
 Length to order (142- 2999 mm) **WLCBX LA222**  
 Weight, 1 m, incl. belt: 14 kg/m

## Beam spacer Kit for WL222

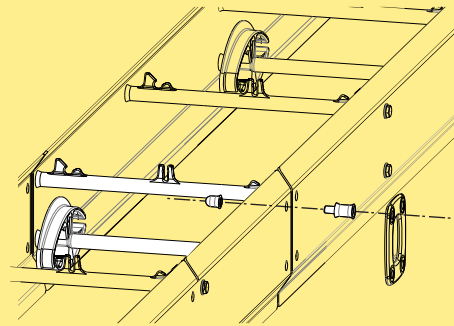
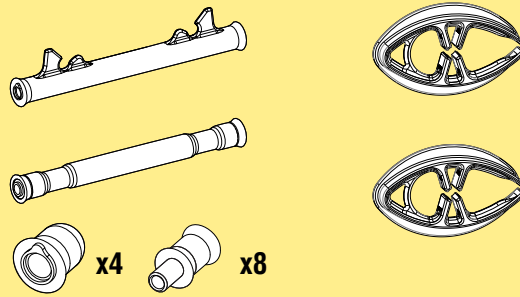

Beam spacer kit **WLCEX A222**

## Connecting bracket kit

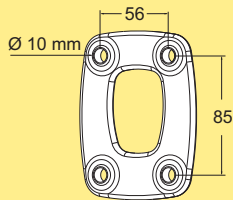

Connecting Bracket  
 For beam **WLCJX 10X56**  
 Including 4 pcs M10 screws

Recommended Torx tool for fasten spacer  
 Size T30

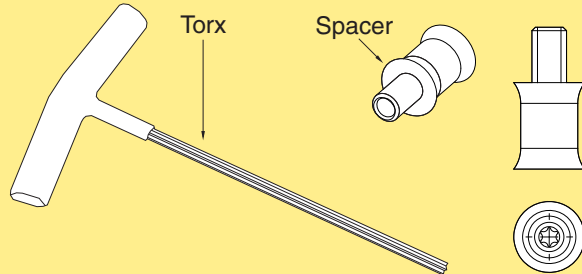

## Beam support brackets

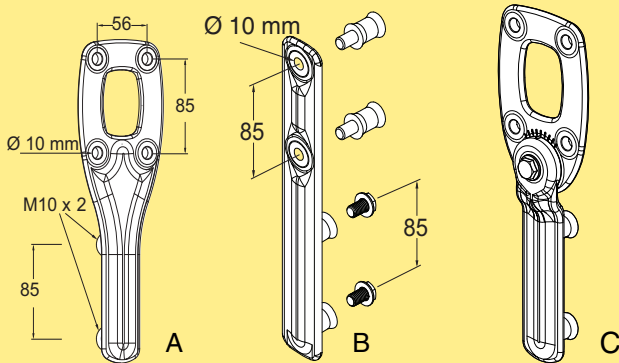

Beam support bracket (A)  
 Including 6 pcs M10 screws **WLCSX 10X56**

Beam support bracket (B)  
 Including 2 pcs M10 screws  
 and 2 pcs spacer WLRDX  
 M10X25 **WLCSX 10**

Beam support bracket (C)  
 Adjustable ±40° **WLCSX 10X56V40**

# Slide rail

## Slide rail

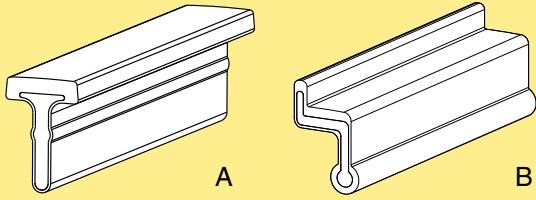

Slide rail, length 3 m  
Slide rail (A)  
Outer slide rail (B)

**WLCRX 3**  
**WLCRX 3 B**

## Connecting Strip

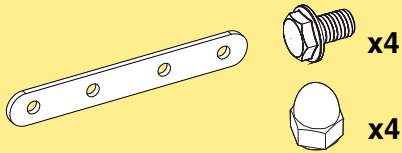

Connecting strip kit  
Contains 10 pcs.

**WLAHX 100**

## Drill fixture for connecting strip

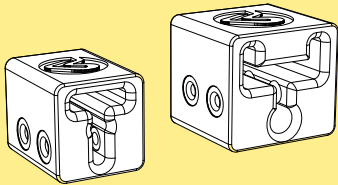

Contains drill fixtures for both  
WLCRX 3 and WLCRX 3B

**5118922**

PO

X70X

X85X

X180X

X300X

WL  
222X

WL  
273X

WL  
374X

WL  
526X

WL  
678X

CSX

GRX

FSTX

TR

APX

IDX

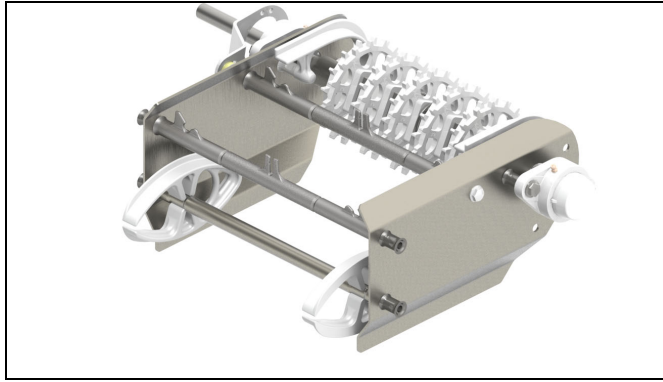

End drive unit

## Technical specifications

Maximal speed..... 40 m/min  
 Number of teeth on sprocket wheel ... 16

## Belt tensioner unit

A belt tensioner unit should always be placed near the End drive unit and its use is recommended:

- for long conveyors >20 meters
- for long conveyors >15 m and a speed of >30 m/min
- for conveyors with frequent starts/stops, especially if the load is high
- if an End drive unit needs to be placed close to a plain bend
- if an End drive unit needs to be placed on the lower part next to a conveyor slope section
- for short conveyors where the belt slack length is insufficient to lift the belt for cleaning

## End drive units

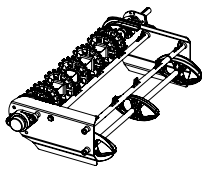
Size	Direct drive, no slip clutch
Drive unit types	 F, V

## Drive unit types

A soft motor start is recommended for use with high-speed and long conveyors. This is because these types of modular belts are quite heavy, and the free hanging return belt can begin to oscillate momentarily during startup.

A grease nipple is included in all flange bearings. The bearings are initially filled with FDA-approved, food-grade grease (NSF H1).

End drive units including SEW motors IP 65, can be ordered with food-grade oil and stainless steel hollow shafts in the web-based configurator.

## Motor specifications

Motors are available for 230/400 V, 50 Hz and 230/460 V, 60 Hz. Variable speed motors are SEW Movimot, 380–500 V. Note that variable speed motors include a control box that adds 120 mm to the width of the motor.

IP55 available with standard oil.

IP65 available with food grade oil.

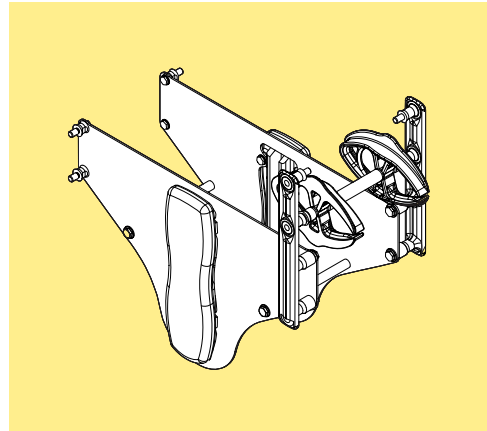

## Ordering information

Drive units with motors must be specified using the web-based configurator. The configurator provides detailed information and step-by-step guidance in the specification process. A product code string is generated, containing the specification details. See next page for examples of code strings.

Drive units *without* motors can be ordered using the designations in the catalogue.

- Connecting brackets have to be ordered separately.
- Slide rail must be ordered separately.

## Dimension

Note that dimensions relating to drive unit motors depend on the motor specified during the configuration.

# Drive units – configuration strings

Below are two examples of text strings obtained from the configurator with explanations.

## Drive unit with fixed speed motor

Item no	A	B	D	E	G	H	I
	HNP	- L	- V4	- SA37	- 50/230	- 0,18kW	- TF

## Drive unit with variable speed motor

Item no	A	B	D	E	F	G	J	K
	HPV	- L	- V6-15	SA37	- MM03	- 50/380-500	- C	- P

### Item no - Drive type

WLEBX: End drive

TF: Thermal protection type TF  
 TH: Thermal protection type TH  
 (position is omitted for variable speed motors)

### A – 0-Unit

HNP: Direct drive, no slip clutch  
 ...V: Variable speed

### J – Hybrid cable

No: No hybrid cable  
 C: Hybrid cable included in SEW Movimot  
 (position is omitted for fixed speed motors)

PO

### B – Motor position

L: Left  
 R: Right

X70X

### D – Speed

V...: Fixed speed... m/min  
 V... -...: Variable speed range...-... m/min

### K – Fieldbus

No: No fieldbus  
 P: Profibus fieldbus, maintenance switch  
 D: DeviceNet fieldbus, maintenance switch  
 (position is omitted for fixed speed motors)

X85X

X180X

X300X

### E – Gearbox

SA37: SEW motor type SA37  
 WA30: SEW gear box type WA30

WL  
222X

WL  
273X

### F – Movimot size

MM03: SEW Movimot type, 0,37 kW  
 MM05: SEW Movimot type, 0,55 kW  
 MM07: SEW Movimot type, 0,75 kW  
 (position is omitted for fixed speed motors)

WL  
374X

WL  
526X

### G – Electrical environment

50/230: 50 Hz, 230 V  
 50/400: 50 Hz, 400 V  
 60/230: 60 Hz, 230 V  
 60/460: 60 Hz, 460 V  
 50/380-500: SEW Movimot variable speed motor

WL  
678X

CSX

GRX

FSTX

### H – Motor power

... kW: Motor power, kW  
 (position is omitted for variable speed motors  
 see position F)

TR

APX

### I – Thermal protection

No: No thermal protection

IDX

## End drive units

### End drive unit Easy Clean, Radius flush grid 222

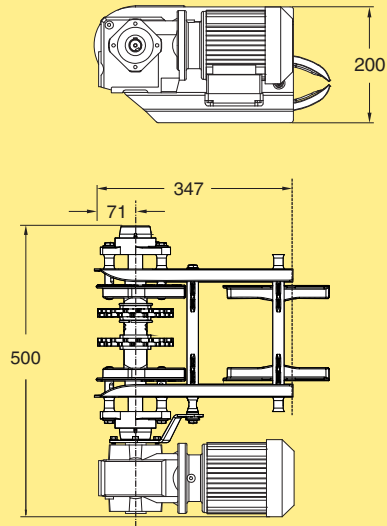

End drive unit **WLEBX A222**  
 Fixed/variable speed\*  
 Without motor:  
 Transmission on left side **WLEBX0A222NLP**  
 Transmission on right side **WLEBX0A222NRP**

\* Use online configurator when ordering  
 Effective track length: 0,80 m  
 Weight, incl belt: 11 kg

### Belt tensioner unit

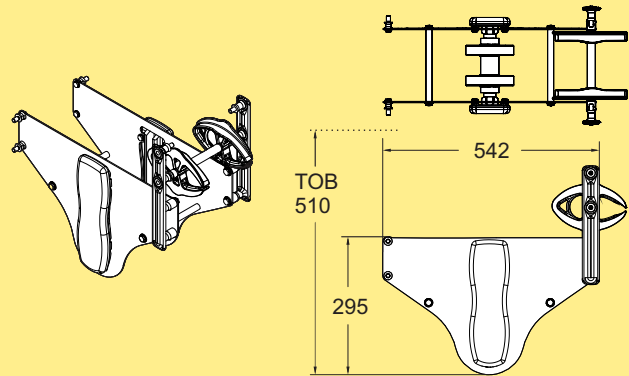

Belt tensioner for:  
 WL222X **5124676**

Required extra belt length **0,55 m**

Weight, incl belt: 13 kg

## Idler end units – Introduction

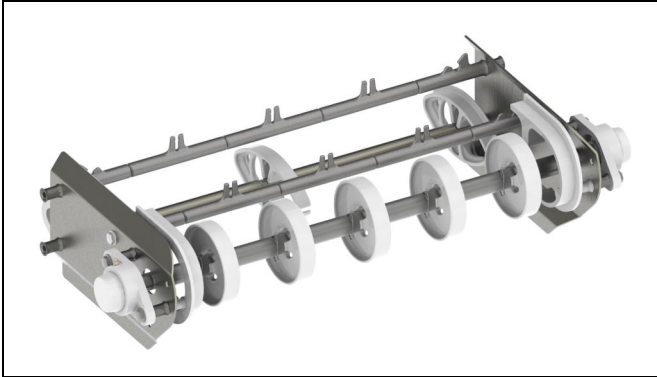

Idler end unit

### Chain guidance at end of conveyor

The idler end unit is used to guide the chain from the return side of the conveyor up to the top side with a minimum of friction. The chain is guided by two or more idler wheels on a common, rotating shaft supported by ball bearings.

### Ordering information

- Connecting strips are included with the idler end units.
- Slide rail must be ordered separately.

## Idler units

### Idler end unit, WL222

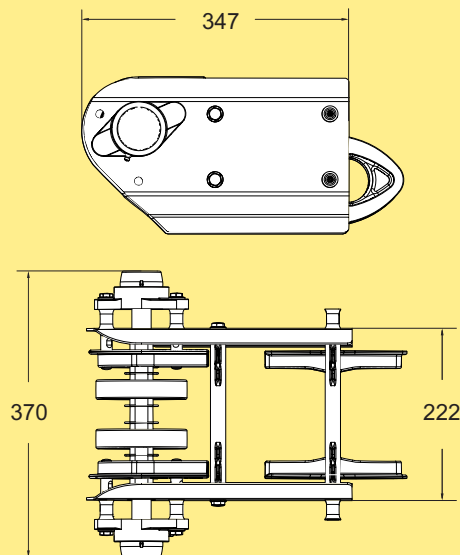

Idler end unit

**WLEJX 300A222**

\* Use online configurator when ordering  
 Effective track length: 0,80 m  
 Weight, incl belt: 11 kg

## Additional features

CIP (Clean-in-Place) unit, engineered for thorough modular belt cleaning to ensure hygiene and minimize contamination.



### CIP washing unit, WL222X, plain belt

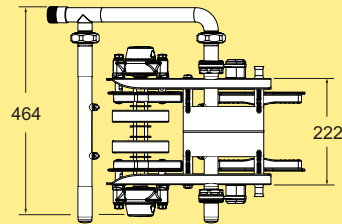
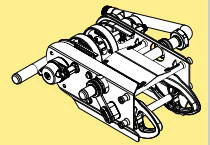
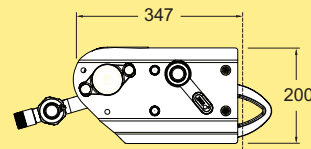

CIP washing unit for plain belt

**WLNWX A222 CIP**

PO  
 X70X  
 X85X  
 X180X  
 X300X  
**WL 222X**  
 WL 273X  
 WL 374X  
 WL 526X  
 WL 678X  
 CSX  
 GRX  
 FSTX  
 TR  
 APX  
 IDX

## Plain Bends - Introduction

When using radius flush grid belts in plain bends, the belt pull force will be concentrated on the outer part of the belt. A certain straight section is needed before and after the bend in order to transfer the load between the outer belt section and evenly distribute it to the straight belt section. This is critical before entering another plain bend, end drive unit, etc. This required straight section is always integrated in the plain bend itself (250 mm for WL222X and WL273X, 300 mm for WL374X, 450 mm for WL526X, and 600 mm for WL678X).

Plain bend placement, as for all other Flexlink conveyors, should always be considered. A plain bend placed too far downstream on a conveyor generates unnecessary belt pull. Also, placement of a plain bend too close to an end drive unit can lead to an unnecessary slack increase and a separate slack unit must be added. Always use the Flexlink calculation tool (FLCT) to calculate the resulting pull forces.

### Plain bend, Easy Clean, 45°

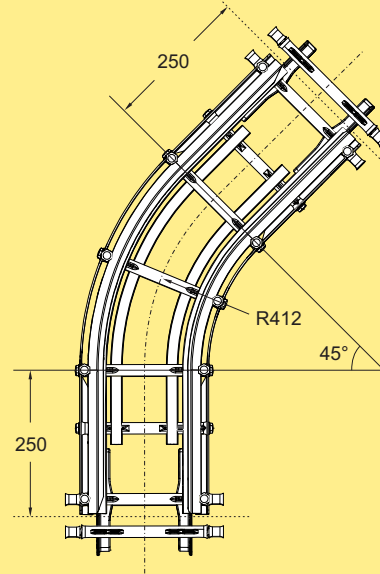

Plain bend, 45°±1°

R=412±10 mm

**WLBPX 45A222**

*\* Use online configurator when ordering*  
 Effective track length: 1,8 m  
 Weight, incl belt: 20 kg

### Plain bend, Easy Clean 30°

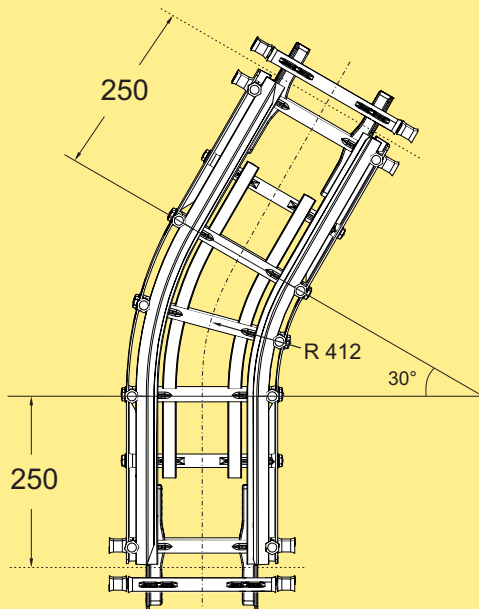

Plain bend, 30°±1°

R=412±10 mm

**WLBPX 30A222**

*\* Use online configurator when ordering*  
 Effective track length: 1,6 m  
 Weight, incl belt: 19 kg

### Plain bend, Easy Clean 60°

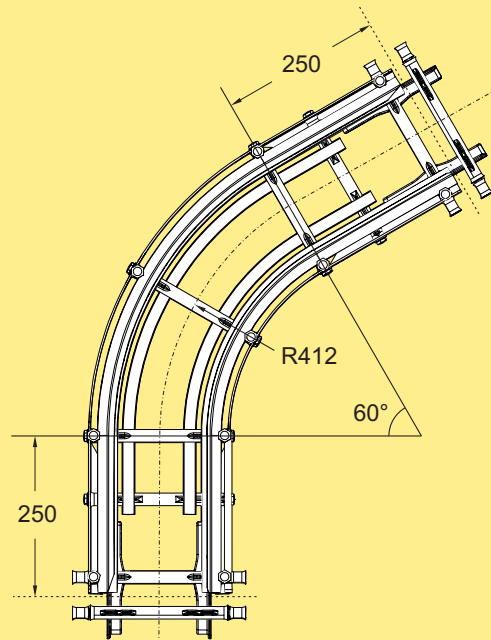

Plain bend, 60°±1°

R=412±10 mm

**WLBPX 60A222**

*\* Use online configurator when ordering*  
 Effective track length: 2,1 m  
 Weight, incl belt: 22 kg

**Plain bend, Easy Clean 90°**

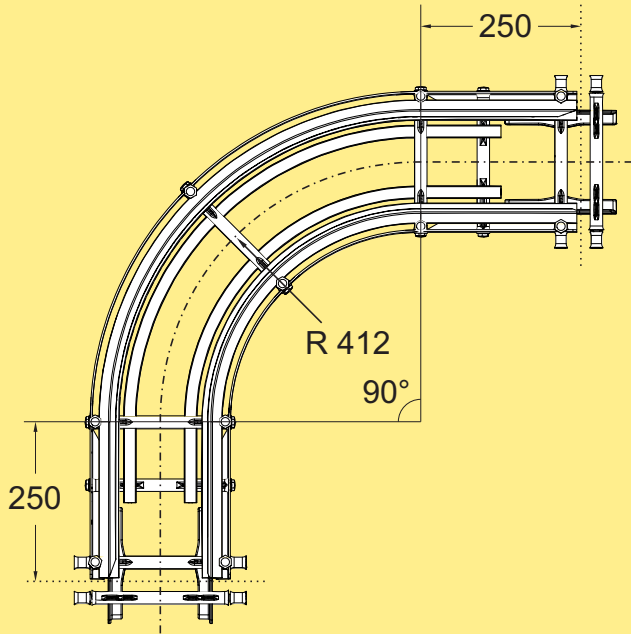

Plain bend, 90°±1°  
R=412±10 mm **WLBPX 90A222**

\* Use online configurator when ordering  
Effective track length: 2,6 m  
Weight, incl belt: 24 kg

**Plain bend, Easy Clean 180°**

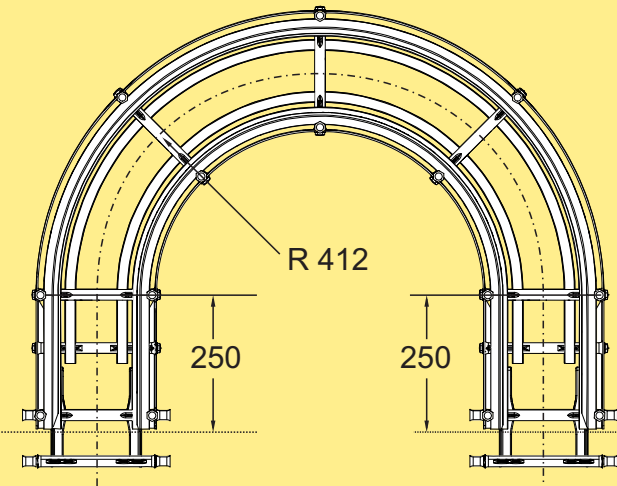

Plain bend, 180°±1°  
R=412±10 mm **WLBPX 180A222**

\* Use online configurator when ordering  
Effective track length: 4,1 m  
Weight, incl belt: 34 kg

**Vertical bend, Easy Clean, 5° (pos.)**

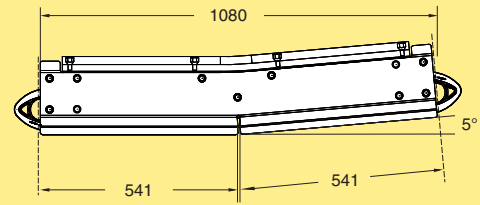

Vertical bend 5°, pos **WLBVX 5A222P**

\* Use online configurator when ordering  
Effective track length: 2,1 m  
Weight, incl belt: 21 kg

**Vertical bend, Easy Clean, 5° (neg.)**

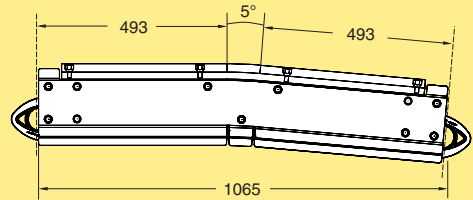

Vertical bend 5°, neg **WLBVX 5A222N**

\* Use online configurator when ordering  
Effective track length: 2,1 m  
Weight, incl belt: 20 kg

**Vertical bend, Easy Clean, 3° (pos.)**

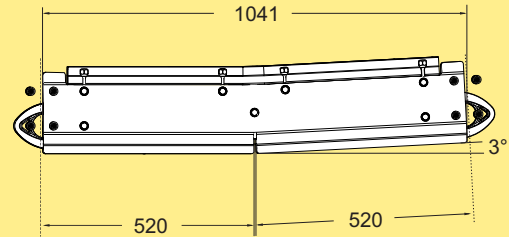

Vertical bend 3°, pos **WLBVX 3A222P**

\* Use online configurator when ordering  
Effective track length: 2,1 m  
Weight, incl belt: 20 kg

**Vertical bend, Easy Clean, 3° (neg.)**

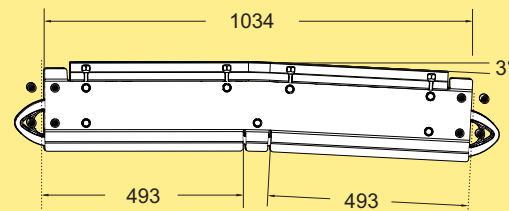

Vertical bend 3°, neg **WLBVX 3A222N**

\* Use online configurator when ordering  
Effective track length: 2,1 m  
Weight, incl belt: 20 kg

PO

X70X

X85X

X180X

X300X

WL  
222X

WL  
273X

WL  
374X

WL  
526X

WL  
678X

CSX

GRX

FSTX

TR

APX

IDX

## Conveyor supports

Support modules must be specified using the online configurator. A product code string is generated that contains the specification details (E.g., WLUFX S01-WL374X-900).

### Support module, single leg

Top of belt  
660 - 1500

Connecting brackets

Adjustable foot  
± 33

Support module, single leg **WLUFX S04**

#### Support module, single leg WLUFX S04

Parameter	Option
Top of belt:	660-1500 mm
Foot type:	XCFSX 16x80 H XCFSX 16x80 HA XCFSX 16x80 XCFSX 16x80 A
Bracket type:	WLCSX 10X56 WLCSX 10

### Support module, type H

Top of belt  
660 - 1500

Connecting brackets

Adjustable foot  
± 33

Support module type H **WLUFX S01**

#### Support module type H, WLUFX S01

Parameter	Option
Platform	WL222X WL273X WL374X WL526X WL678X
Top of belt:	660-1500 mm
Foot type:	XCFSX 16x80 H XCFSX 16x80 HA XCFSX 16x80 XCFSX 16x80 A
Bracket type:	WLCSX 10X56 WLCSX 10 WLCSX 10X56V40

### Foot holder for adjustable foot

M10 (x2)

85

46

31

M16  
Depth 100

Foot holder  
Including 2 pcs M10 screws **XCFCX 16x100**

### Adjustable foot

M16

243

37 Max

66 Min

Ø 80

Ø 15 mm

Adjustable foot

M16	<b>XCFSX 16x80</b>
M16, Anchoring	<b>XCFSX 16x80 A</b>
M16, EHEDG/3A	<b>XCFSX 16x80 H</b>
M16, EHEDG/3A, Anchoring	<b>XCFSX 16x80 HA</b>