

Conveyor system XM – links and chains

Each link kit contains 10 links, 10 plastic pivots, and 10 stainless steel pins, unless otherwise specified. Material abbreviations: See page III.

Plain chain

Chain	Link(s)	Link kit(s)	Dimensions	Link weight	Material, link	Material, pivot
XMTP 5	XMTL 83	5056281		27 g	POM A	See page III
3924106	XMTL 83	5056282		27 g	POM A	PVDF
3927364	3927363	5056283		27 g	POM A GY	See page III
3905592	3905591	5056284		27 g	POM A BK	See page III
3921449	3901448	5056285		27 g	POM B	See page III
3905538	3905537	5056286		27 g	POM B POLISHED	See page III
XMTP 5 E	XMTL 83 E	5056287		27 g	POM A COND	PA66 ISD
3924116	3924115	5056288		27 g	PVDF	See page III
3925937	3925936	5056289		27 g	POM B ISD NAT	See page III
3927484	3927483	5056290		27 g	POM B ISD GY	See page III
XMTP 5 C	n.a.	n.a.			POM D	See page III

Plain chain

Chain	Link(s)	Link kit(s)	Dimensions	Link weight	Material, link	Material, pivot
5047887	5047886	5056291		30 g	POM A	See page III

Minimum horizontal bend radius: 500 mm. Minimized gap between links.
 Note! Can not be used together with Compact or Medium units or Compact idler end unit.

Plain chain

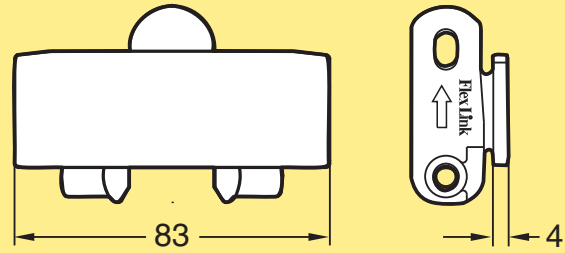
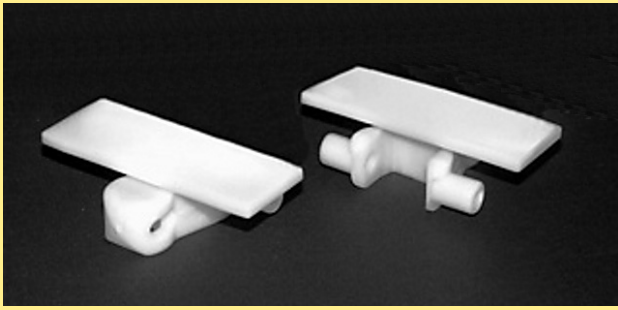

Minimum horizontal bend radius 700 mm.

Note! Can not be used together with Compact or Medium units or Compact idler end unit.

Chain	Link(s)	Link kit(s)	Dimensions	Link weight	Material, link	Material, pivot
5055061	3920660	5056307		30 g	POM A	See page III

Flocked chain

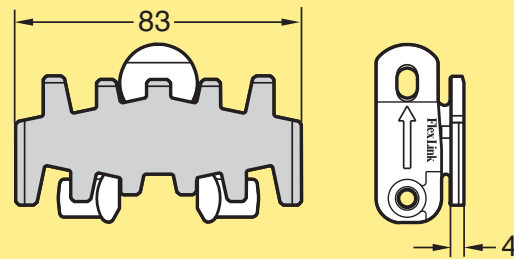
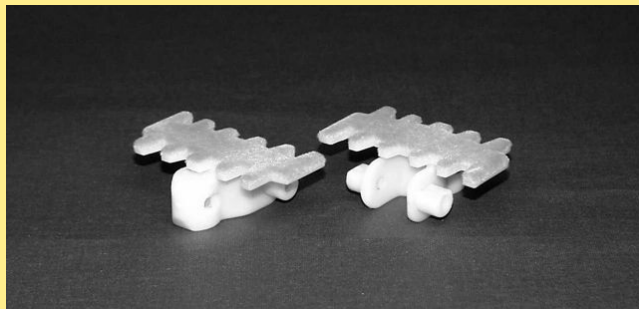

For lightweight products with scratch sensitive surfaces. Perfume boxes, cosmetic packages, CD's, Cigarette packages. Fibre material is PA66, glued to the link using epoxy glue.

Chain	Link(s)	Link kit(s)	Dimensions	Link weight	Material, link	Material, pivot
5048331	n.a.	n.a.			POM B	See page III

Universal chain

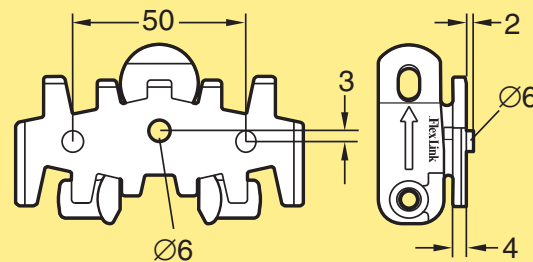
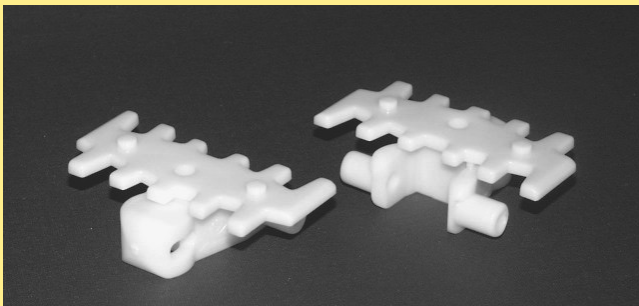

To attach customer specific cleat or fixture. The link has a hole for an M6 screw. An M6 nut will fit inside the link.

Chain	Config.	Link(s)	Link kit(s)	Dimensions	Link weight	Material, link	Material, pivot
XMTF 5 U	PAR 1-20	XMTL 83 U XMTL 83*	5056094		27 g	POM A	See page III

*Link type between main cleat links.

Universal base chain

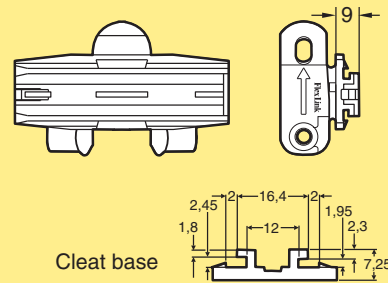
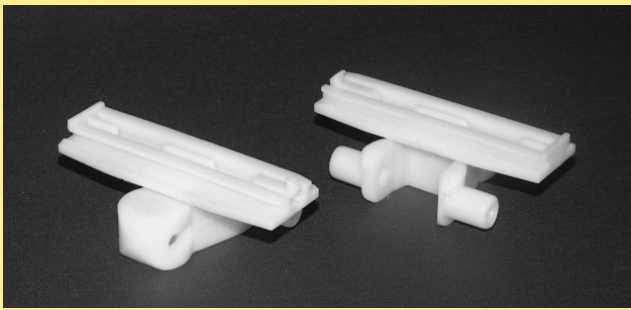

To attach customer specific cleat or fixture.

Chain	Link(s)	Link kit(s)	Dimensions	Link weight	Material, link	Material, pivot
XMTU 5	XMTM 83	5056292		29 g	POM A	See page III

Friction top chain

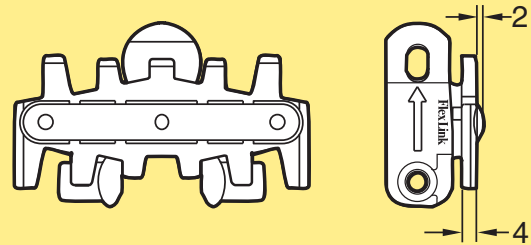
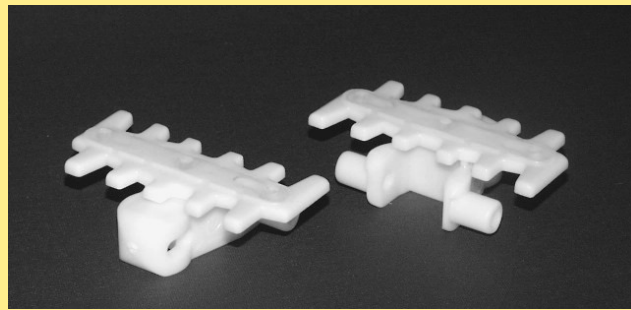

Friction insert is polyether-polyamide. Slope <math><30^\circ</math>. Paper bags, cardboard boxes.

Chain	Config.	Link(s)	Link kit(s)	Dimensions	Link weight	Material, link	Material, pivot
XMTP 5 F	-	XMTL 83 F	5056102		29 g	POM A	See page III
XMTP 5 FP	PAR 2-20	XMTL 83 F XMTL 83*	5056102				

*Link type between main cleat links.

Flat top friction chain

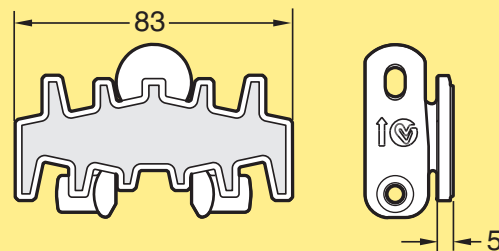
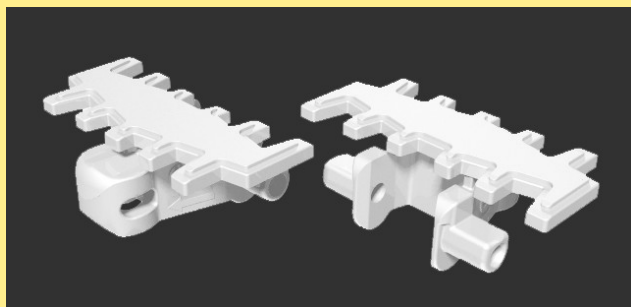

Friction insert is polyether-polyamide. Slope <math><30^\circ</math>. Light goods: blister packs, small boxes, etc.

Chain	Link(s)	Link kit(s)	Dimensions	Link weight	Material, link	Material, pivot
XMTP 5 FA	XMTL 83 FA	5059114			POM A	See page III

Steel top chain

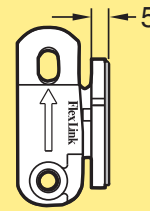
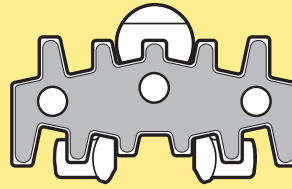
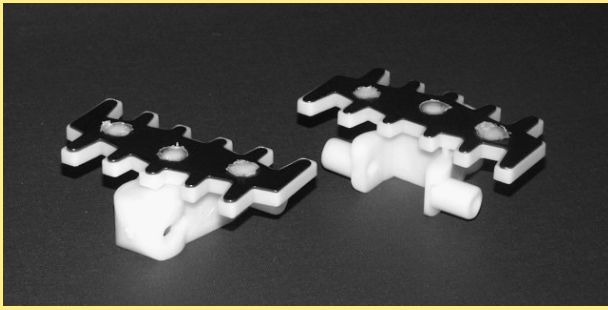

Top surface is stainless steel. Cylindrical rollers. Cast-metal products. Accumulation.

Chain	Link(s)	Link kit(s)	Dimensions	Link weight	Material, link	Material, pivot
XMTF 5 TF	XMTL 83 TF	5056095		46 g	POM A + SS	See page III

Steel chain

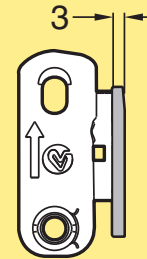
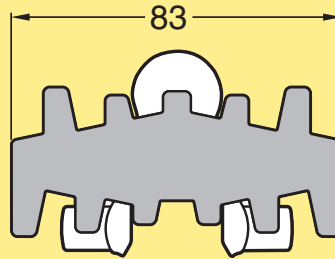
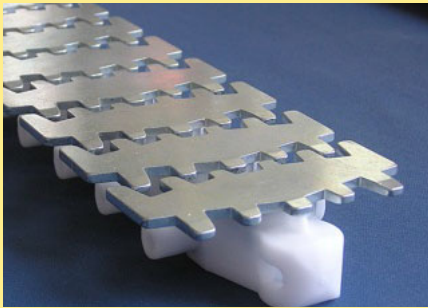

Electro-zincplated hardened steel (700HV1) throughout top part. Modification kits are required for end drive units and wheel bends. Can be used in system X85.

Chain	Link(s)	Link kit(s)	Dimensions	Link weight	Material, link	Material, pivot
5056849	5056847	5058301		64 g	POM B + Steel	See page III

Cleated chain

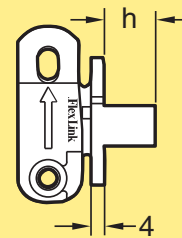
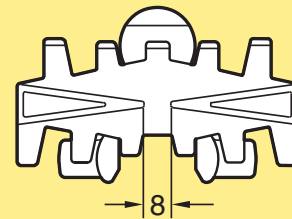
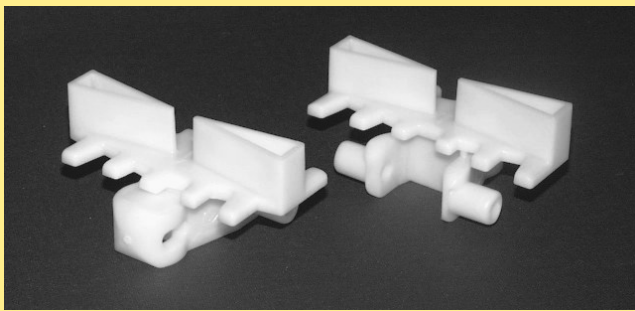

Chain	Config.	Link(s)	Link kit(s)	Dimensions	Link weight	Material, link	Material, pivot
XMTF 5X15 A	PAR 1-20	XMTL 83X15 A XMTL 83*	5056092	h=15 mm	35 g	POM A	See page III
XMTF 5X30 A	PAR 1-20	XMTL 83X30 A XMTL 83*	5056090	h=30 mm	43 g	POM A	See page III

*Link type between main cleat links.

Modifiable cleated chain

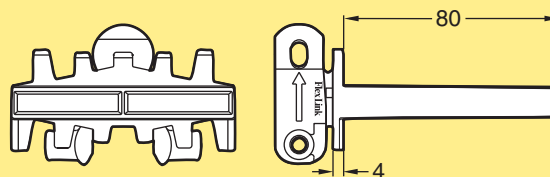

Requires modified drive unit or use direct drive. Vertical transport.
Cleat can be cut to desired height.

Chain	Config.	Link(s)	Link kit(s)	Dimensions	Link weight	Material, link	Material, pivot
XMTF 5X80 D	PAR 1-20	XMTL 83X80 D XMTL 83*	5056087		75 g	POM A	See page III

*Link type between main cleat links.

Cleated chain

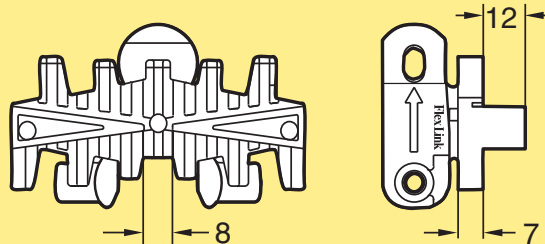
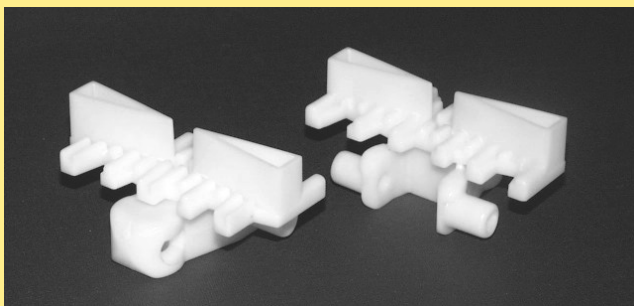

Chain	Config.	Link(s)	Link kit(s)	Dimensions	Link weight	Material, link	Material, pivot
3924170	PAR 1-20	3904502 3904503*	5056293 5056294		38 g	POM A	PVDF

*Link type between main cleat links.

Plain chain with elevated surface

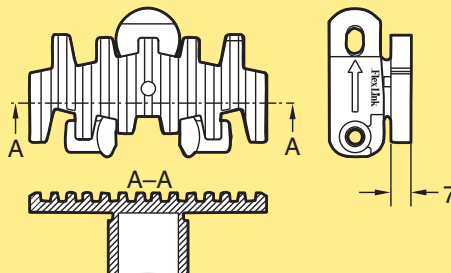
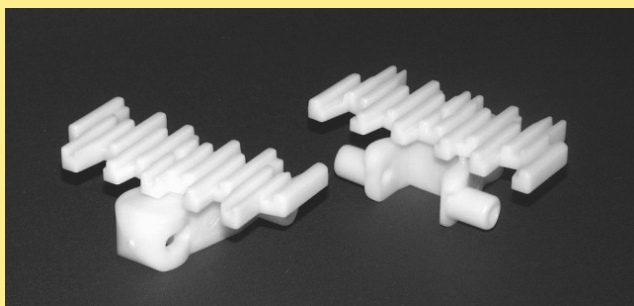

Wet applications.

Chain	Link(s)	Link kit(s)	Dimensions	Link weight	Material, link	Material, pivot
3924171	3904503	5056294		32 g	POM A	PVDF

Cleated chain

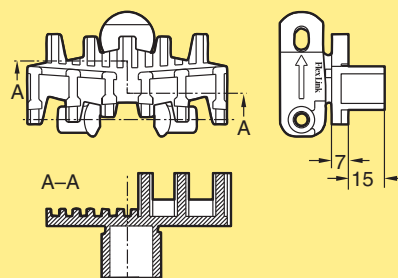
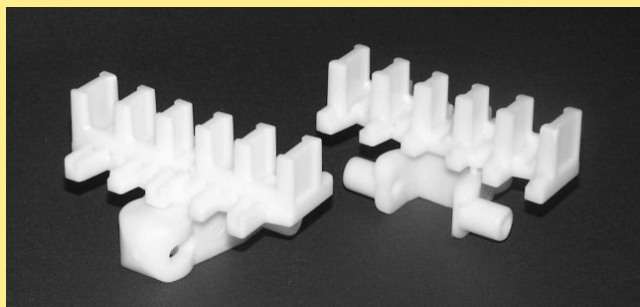

Chain	Config.	Link(s)	Link kit(s)	Dimensions	Link weight	Material, link	Material, pivot
3924174	PAR 1-20	3904667	5056295		42 g	POM A	PVDF
		3904503*	5056294				

*Link type between main cleat links.

Cleated chain

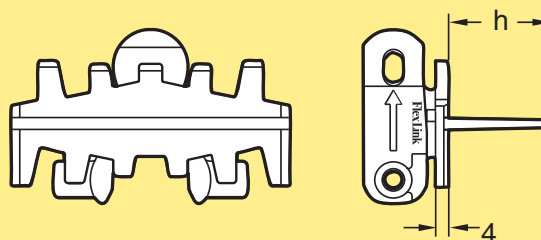
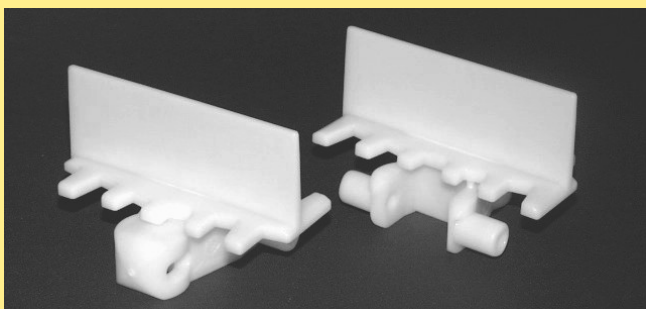

Vertical transport. Rectangular products, sensitive to point load.

Chain	Config.	Link(s)	Link kit(s)	Dimensions	Link weight	Material, link	Material, pivot
5050235	PAR 1-20	5050236 XMTL 83*	5056296	h=15 mm	33 g	POM A	See page III
5050531	PAR 1-20	5050532 XMTL 83*	5056297	h=20 mm	35 g	POM A	See page III
3924100	PAR 1-20	3904668 XMTL 83*	5056298	h=30 mm	38 g	POM A	See page III
3924107	PAR 1-20	3904668 XMTL 83*	5056299	h=30 mm	35 g	POM A	PVDF

*Link type between main cleat links.

Cleated chain

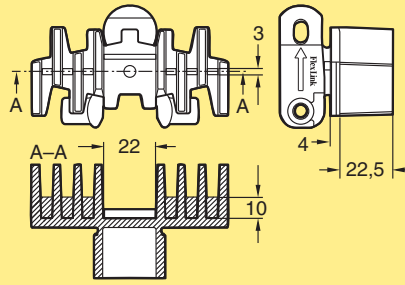
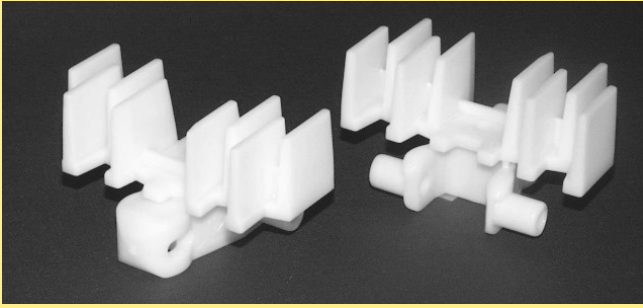

Chain	Link(s)	Link kit(s)	Dimensions	Link weight	Material, link	Material, pivot
3924443	3904689	5056300		51 g	POM A	See page III

Cleated chain

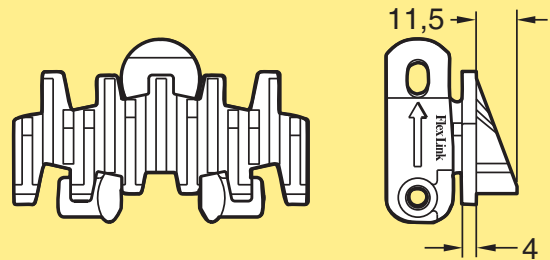
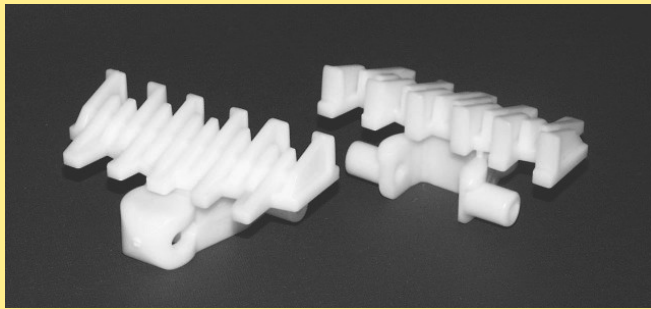

Cardboard boxes. Suitable to reduce accumulation forces in slopes (10°-20°).

Chain	Config.	Link(s)	Link kit(s)	Dimensions	Link weight	Material, link	Material, pivot
3905920	PAR 1-20	3905692 XMTL 83*	5056301		38 g	POM A	See page III

*Link type between main cleat links.

Cleated chain

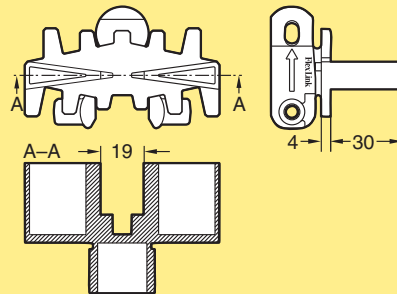
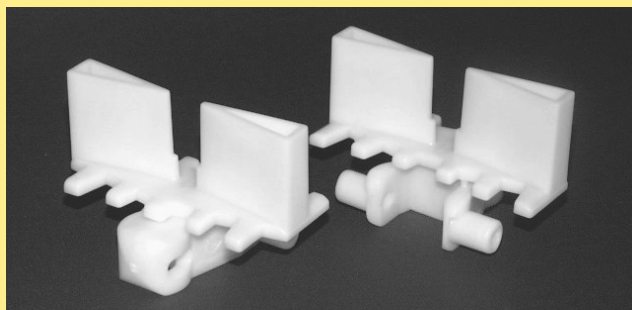

Vertical transport. Crank shafts.

Chain	Config.	Link(s)	Link kit(s)	Dimensions	Link weight	Material, link	Material, pivot
3924173	PAR 1-20	3910012 XMTL 83*	5056302		42 g	POM A	See page III

*Link type between main cleat links.

Cleated chain

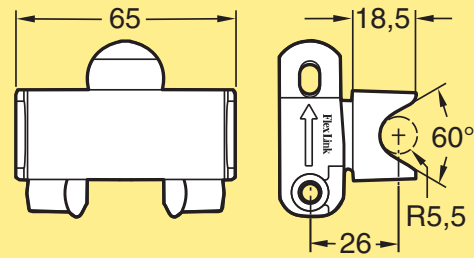
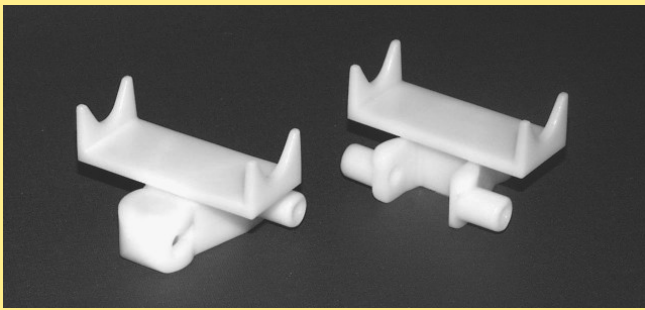

Tubes placed in cleat. Can not be used in horizontal bends.

Chain	Link(s)	Link kit(s)	Dimensions	Link weight	Material, link	Material, pivot
3921528	3921527	5056303		28 g	POM A	See page III

V-block chain

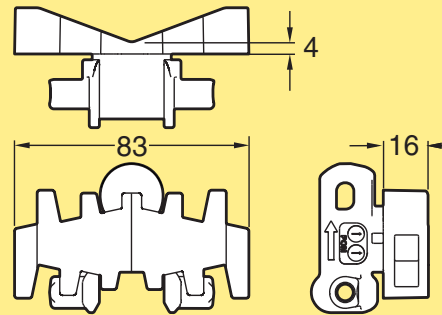
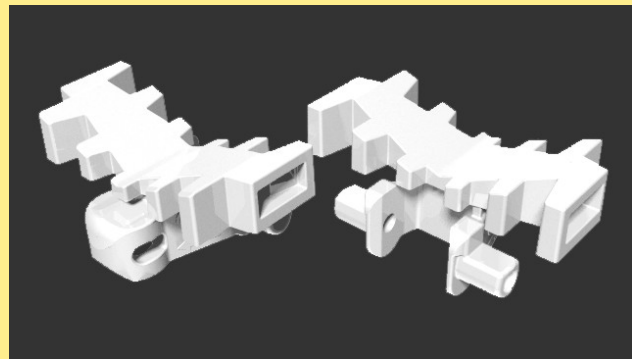

Chain	Link(s)	Link kit(s)	Dimensions	Link weight	Material, link	Material, pivot
5059239	5059255	-			POM B	See page III

Cleated chain

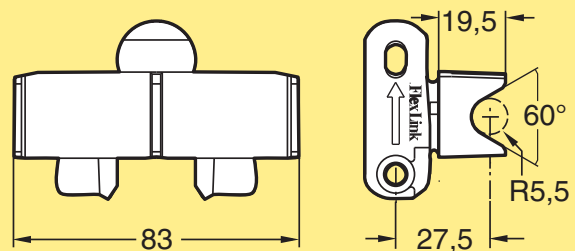
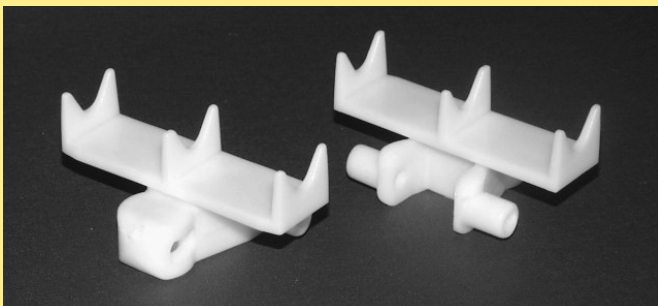

Tubes placed in cleat. Can not be used in horizontal bends.

Chain	Config.	Link(s)	Link kit(s)	Dimensions	Link weight	Material, link	Material, pivot
3924473	PAR 1-20	3924472 XMTL 83*	5056304		31 g	POM A	See page III

*Link type between main cleat links.

Cleated chain

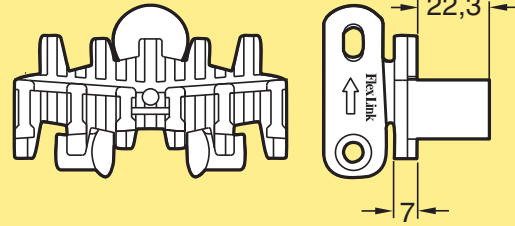
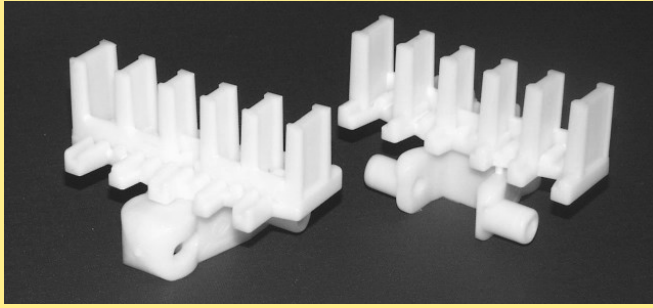

Chain	Config.	Link(s)	Link kit(s)	Dimensions	Link weight	Material, link	Material, pivot
3905553	PAR 1-20	3905552	5056305		44 g	POM A	See page III
		3904503*	5056294				

*Link type between main cleat links.

Cleated chain

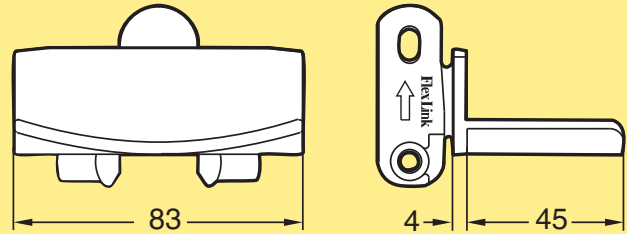
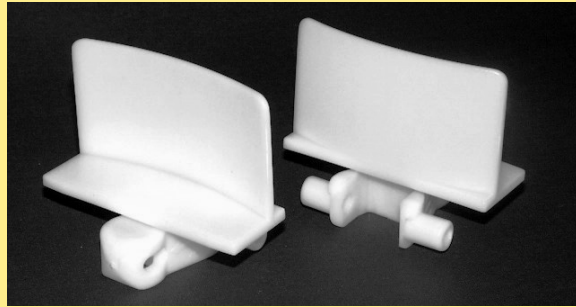

Minimum horizontal bend radius 700 mm.
Note! Can not be used together with Compact or Medium units or Compact idler end unit.

Chain	Config.	Link(s)	Link kit(s)	Dimensions	Link weight	Material, link	Material, pivot
3920662	PAR 1-20	3920661	5056306		30/45 g	POM A	See page III
		3920660*	5056307				

*Link type between main cleat links.

Flexible cleat chain

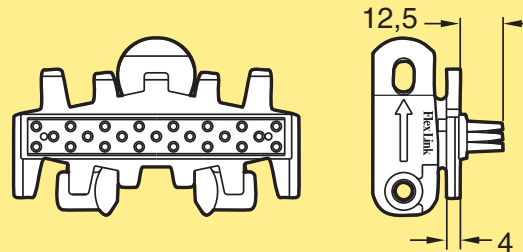
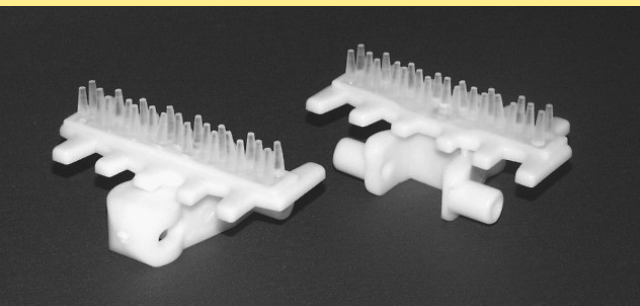

Wedge transport. Recommended for horizontal light products e.g. paper bags, bottles and cans. Max. product weight: 3,0 kg. Flexible insert is polyether-polyamide.

Chain	Link(s)	Link kit(s)	Dimensions	Link weight	Material, link	Material, pivot
XMTE 5 B	XMTL 83 B	5056310		31 g	POM A	See page III

Flexible cleat chain

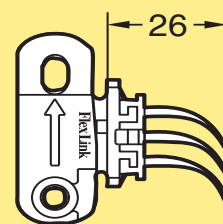
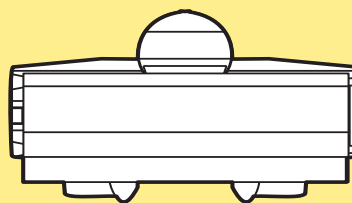
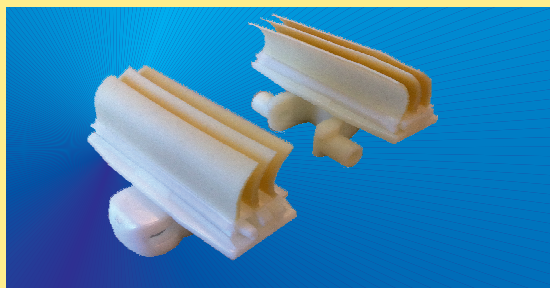

Wedge transport. Soft, flexible surface for sensitive items. Max product weight: 2,0 kg.

Flexible cleat is polypropylene + thermo-plastic elastomer.

Link kit 5056292: 10 base links (XMTM 83) + pins + pivots.

Link kit 5056309: 10 flexible cleat tops (XMTX 78 C).

Chain	Link(s)	Link kit(s)	Dimensions	Link weight	Material, link	Material, pivot
XMTE 5 C	XMTM 83 C	n.a.		40 g	POM A	See page III
	XMTX 78 C	5056309				
	XMTM 83	5056292				

Flexible cleat chain

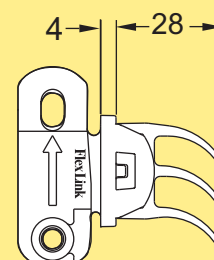
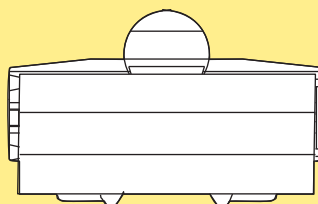
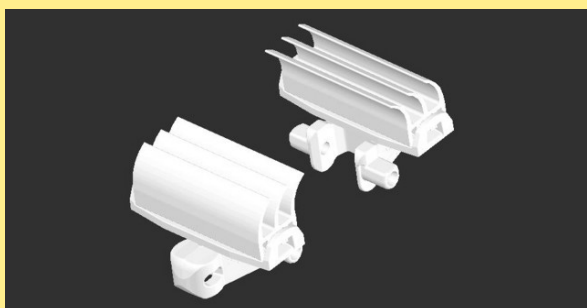

Wedge transport. Soft, flexible surface for sensitive items. Max product weight: 2,0 kg.

Flexible cleat is thermo-plastic elastomer.

Link kit 5110515: 10 flexible cleat tops (5059801).

Chain	Link(s)	Link kit(s)	Dimensions	Link weight	Material, link	Material, pivot
XMTE 5 CA	n.a.	n.a.		40 g	POM B	See page III
	5059801	5110515				
	XMTE 83 D	n.a.				

Flexible cleat chain

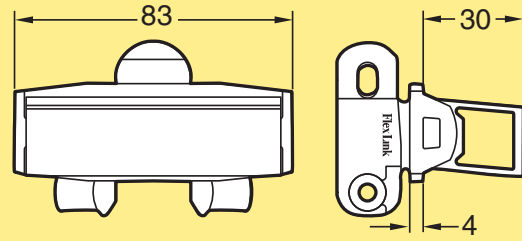
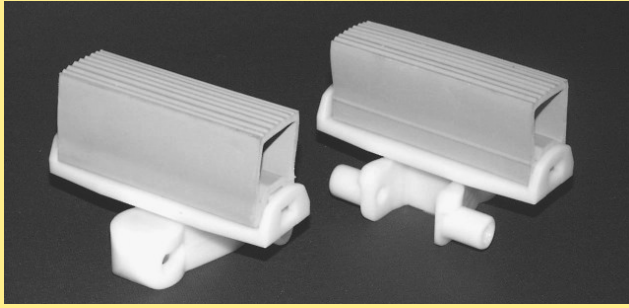

Wedge transport. Recommended for irregular shapes. Max. product weight: 4,0 kg. Flexible cleat is EPDM rubber. Link kit 5059350: 10 base links incl flexible cleat tops (XMTM 83 D) + pins + pivots. Link kit 5056311: 10 cleat tops XMTX 75 D.

Chain	Link(s)	Link kit(s)	Dimensions	Link weight	Material, link	Material, pivot
XMTE 5 D	XMTM 83 D	5059350		66 g	POM B	See page III
	XMTX 75 D	5056311				
	XMTE 83 D	n.a.				

Roller top chain

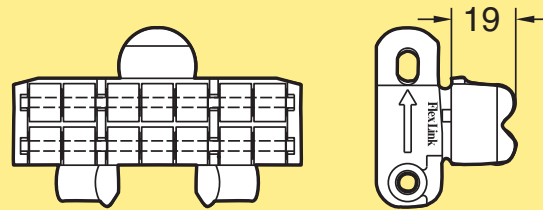
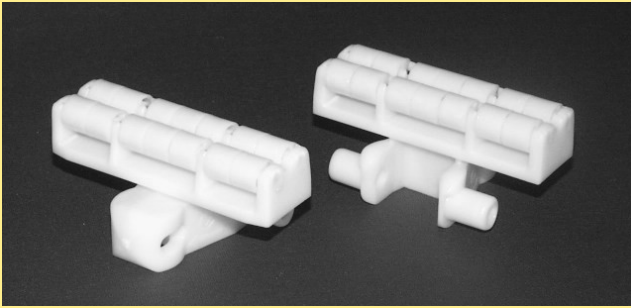

Link cannot be used together with plain links in conveyors with bends. Accumulation of parcels for lower pressure.

Chain	Link(s)	Link kit(s)	Dimensions	Link weight	Material, link	Material, pivot
XMTR 5	XMTL 83 R	5056100		58 g	POM A	See page III

(3902819 Roller, order in multiples of 200 Pcs)

Roller cleat chain

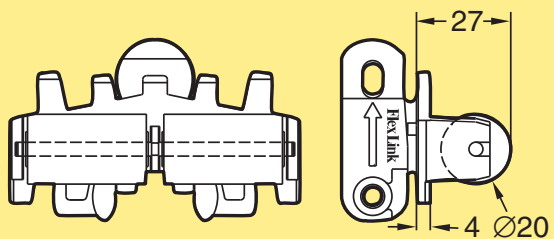
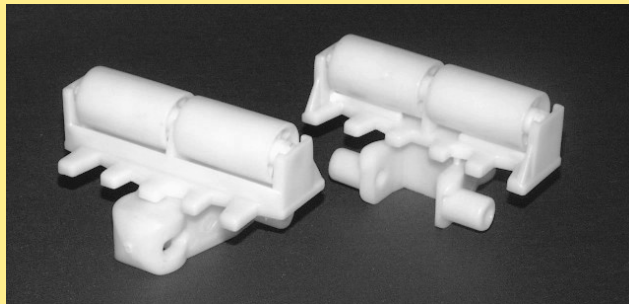

Roller support items in steel and aluminium. Accumulation of parcels for lower pressure. Cardboard boxes.

Chain	Link(s)	Link kit(s)	Dimensions	Link weight	Material, link	Material, pivot
XMTF 5X23 R	XMTL 83X23 R	5056091		59 g	POM A	See page III

Roller cleat chain

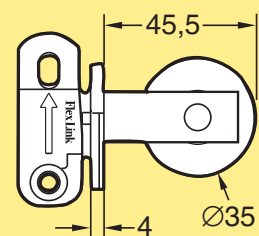
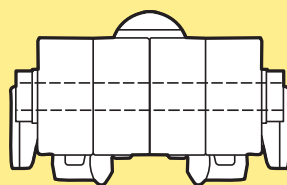
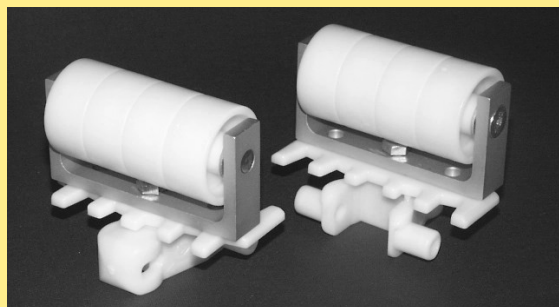

Roller support items in steel and aluminium. Vertical transport of cardboard boxes.
 Link kit 5056088: 1 link XMTL 83x46 R with pivot and steel pin.

Chain	Config.	Link(s)	Link kit(s)	Dimensions	Link weight	Material, link	Material, pivot
XMTF 5X46 R	PAR 1-20	XMTL 83X46 R XMTL 83*	5056088		143 g	POM A	See page III

*Link type between main cleat links.