

PRE-REQUISITES

Recommended tools

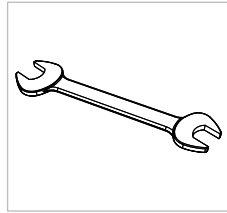

SAFETY

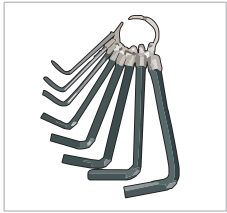

WARNING
The system must not be operated without safety equipment properly mounted.



WARNING
At installation, maintenance and service, make sure the motor is shut off.



WARNING
Moving parts.

COMPONENTS

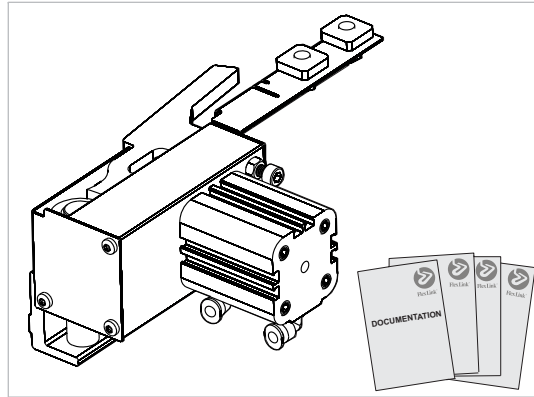

Safety equipment, use with Pallet Locating Station

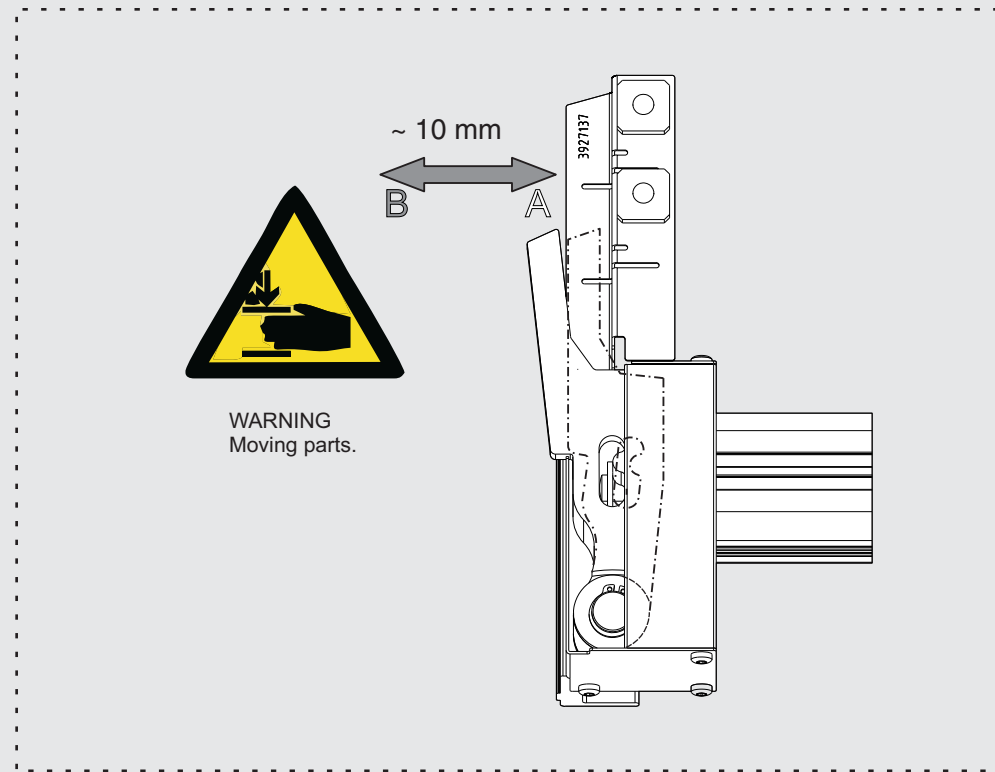
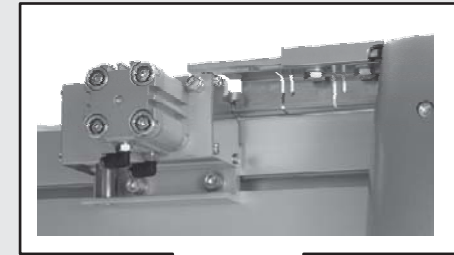

Production flow direction

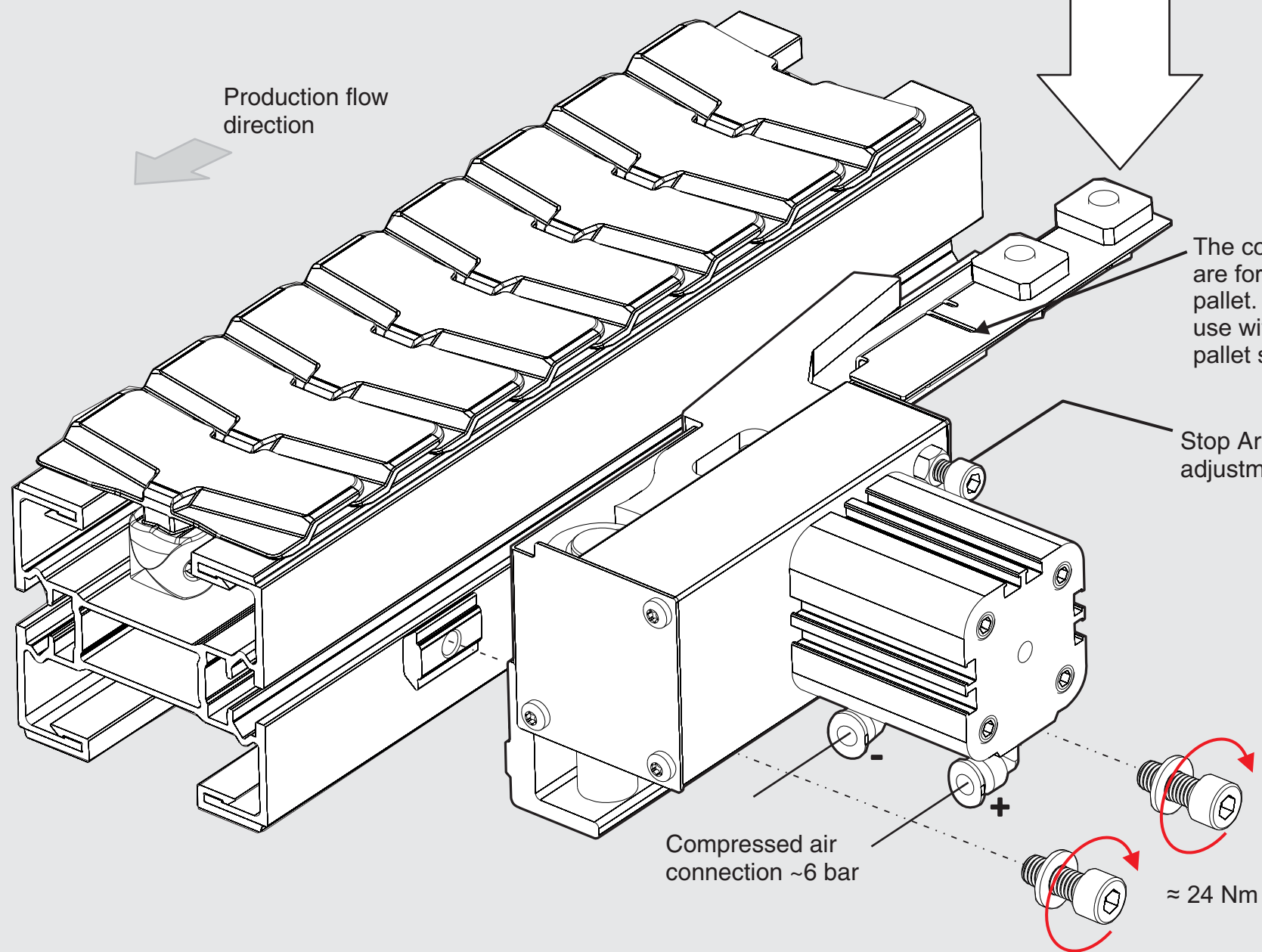

The cover dimensions are for use with the largest pallet. It can easily be cut for use with other standard pallet sizes.

FlexLink Components AB
SE-41550 Göteborg
Sweden

We hereby declare that the following equipment is intended to be incorporated into a FlexLink conveyor system and thereby forming a machine. Operation is prohibited until it has been determined that the machine in which these products are incorporated, has been declared in conformity with the Machinery Directive 2006/42/EC, together with amendments which have entered into force as of the date of issue of this declaration, with particular reference to the essential health and safety requirements in connection with the design, construction and manufacture of the below specified equipment.

- Pneumatic stop XKPD 32x15 LB

Corresponding EC directives:

Applied transposed harmonized European standards:

EN ISO 14121-1 Safety of machinery – Risk assessments

EN ISO 12100-1 Safety of Machinery - Basic terminology, methodology

EN ISO 12100-2 Safety of Machinery - Technical principles

FlexLink Components AB



Svante Anderholm
Chief Operating Officer

Flexlink Components AB



Anders Jonsson
Responsible Technical file

FlexLink Components AB

ASSEMBLY INSTRUCTION

**Pneumatic Stop
XKPD 32x15 LB**

