

**CONVEYOR SYSTEMS
XS, XL, XM, XH, XK, XB**

Maintenance manual



a coesia company



a coesia company

© Flexlink AB 2025

All Rights Reserved

No part of this program and manual may be used, reproduced, stored or transmitted in any form or by any means without the written permission of FlexLink AB. The contents of this manual are for informational use only. All information and specifications contained in this document have been carefully checked to the best efforts of FlexLink AB, and are believed to be true and accurate as of time of publishing. However, due to continued efforts in product development FlexLink AB reserves the right to modify products and its manuals without notice.

FlexLink AB assumes no responsibility or liability on any errors or inaccuracies in this program or documentation. Any kind of material damages or other indirect consequences resulting from any FlexLink AB's product part, documentation discrepancies and errors or non-anticipated program behavior are limited to the value of appropriate products purchased from FlexLink AB. The products are delivered to the customer at the 'as is' state and revision level they are on the moment of purchasing, and are declared in detail in the license agreements between FlexLink AB and user. User accepts and is obliged to follow the guidelines stated in the separate license agreement needed in using any parts of this product package.

1	General safety and design considerations	1
1.1	Introduction	1
1.1.1	Critical factor	1
1.1.2	Safeguarding	1
1.1.3	Special considerations	2
2	Safety	3
2.1	System information	3
2.2	Important safety conditions	3
2.2.1	General	4
2.2.2	Maintenance and Service technicians	6
2.2.3	Electricians	6
2.2.4	Operators	6
3	Maintenance	7
3.1	System maintenance	7
3.1.1	Introduction	7
3.1.2	Non FlexLink equipment	7
3.1.3	Safety considerations	7
3.2	Maintenance instructions	8
3.2.1	Introduction	8
3.2.2	Warranty/guarantee	8
3.2.3	Spare/replacement parts	8
3.2.4	Checklist/maintenance schedule	8
3.2.5	Important	8
3.3	Introduction to drive units	9
3.3.1	Four types	9
3.4	Slip clutch adjustment	11
3.4.1	Old and new versions	11
3.4.2	Introduction	11
3.5	Inspection – drive units	15
3.5.1	Roller chain transmission	15
3.5.2	Worm gear motor and geared motor	15
3.5.3	Guide for the conveyor chain	15
3.5.4	General checks on drive unit	16

3.6	Inspection – conveyor chains	17
3.6.1	Conveyor chains	17
3.6.2	Checking the tension of conveyor chain	18
3.6.3	Important:	19
3.6.4	Shortening conveyor chains	20
3.7	Inspection – slide rails, beams, idlers, bends	22
3.7.1	Checking slide rails	22
3.7.2	Conveyor beams, idler ends, and bends	23
3.8	Inspection – safety devices	24
3.9	Replacement of worn parts – conveyor chain	25
3.9.1	Removal of conveyor chain	25
3.9.2	Fitting the conveyor chain	26
3.10	Replacement of worn parts – slide rails	27
3.10.1	Replacing slide rails	27
3.11	Anchoring slide rail	29
3.11.1	Fixing slide rail to the conveyor beam	29
4	Troubleshooting	34
4.1	Jerky running	34
4.2	Drive unit is running, conveyor chain is not	34
4.3	Motor overheating on drive unit	34
4.4	Noise	35
4.5	Abnormal wear on plastic parts	35
5	Checklist/maintenance schedule	36
6	System dismantling and disposal	37
6.1	Important safety precautions	37
6.1.1	Dismantling	37
6.2	Recycle	39

1 General safety and design considerations

1.1 Introduction



1.1.1 Critical factor

To achieve an operational installation which is reasonably safe for all people involved in its use and maintenance, it is necessary to consider certain aspects. This is done when designing a conveyor system. The chain is generally the critical factor to consider with guarding.

1.1.2 Safeguarding

All pinch and shear points as well as other exposed moving parts that present a hazard to people at their workstations or their passageways must be safeguarded. Overhead conveyors must be guarded to prevent objects falling. Cleated conveyor chains are more hazardous in creating more pinch and shear points than plain conveyor chains.

1.1.2.1 *Safeguarding can be achieved by:*

- **Location**
Location of the hazardous area away from the area occupied by personnel, wherever possible.
- **Guards**
Mechanical barriers preventing entry into the hazardous areas or protecting against falling objects.
- **Control devices**
Machine controls which prevent the interruption of hazardous operations/conditions.
- **Warnings**
Instructions, warning labels, or sound/light signals which alert to hazardous conditions.
Safeguarding should be designed to minimize discomfort or difficulties to the operator. Bypassing or overriding the safeguarding during operation should be difficult.
Warning labels etc. should only be used when all other means of safeguarding will impair the function of the installation or are not cost effective.
The degree of safeguarding required should be identified during the implementation of the essential safety requirement during the design process.

1.1.3 Special considerations

When correctly applied, the FlexLink components are safe to use and maintain. It is however necessary for those responsible for design, installation, operation and maintenance of the FlexLink installation to be aware of certain areas where special attention is required.

1.1.3.1 *All drive units with slip clutch*

- Before adjusting the slip clutch it is necessary to remove all objects from the chain to remove any remaining chain tension.
- Adjustment should be conducted in accordance with the maintenance procedures.
- All drive units, except the direct drive units, are fitted with transmission chain covers. These covers must be fitted before the unit is operated.

NB: *The slip clutch is not a personnel safety device, but a device to protect the conveyor equipment.*

2 Safety

The machine has been designed in such a way, that it can be used and maintained in a safe way. This holds for the application, the circumstances and the instructions described in this manual. Any person working with or around this machine should study the manual and follow the instructions. It is the responsibility of the employer to make sure that the employee is familiar with, and follows, these instructions.

The company or the country in which the machine is used may require extra safety measures. This particularly applies to the working conditions. This manual does not describe how these are to be complied with. In case of doubt, consult your government or safety officer!

2.1 System information

The order number and/or general drawing number shall always be specified when communicating with FlexLink with respect to the machine.

2.2 Important safety conditions

Before the machine shall be operated by a user, the following safety conditions must be met:

Make sure that children or animals have no access to the machine and its surrounding areas by, for example, screening off the machine with a fence.

Only personnel who have read and understood the operating instructions are allowed to operate, maintain and clean the machine.

Do not reach into the machine while it is running or on. Even if the machine is not running, it can be 'on', which means start operating automatically.

Safety provisions, such as side guards, bottom guards, emergency stops and detectors shall not be removed or deactivated while the machine is running.

Provide good ambient lighting to enable the operator to work well and orderly with the machine.

2.2.1 General

- Incorrect use of the equipment can cause personal injury.
- Do not stand or climb on the equipment.
- Do not wear clothing or other articles that can fasten in the machine.
- For coupled drive units, safety protection should be applied to the connecting shaft.

2.2.1.1 *End drive units*

- The chain slack length at the end drive units must be maintained during the system lifetime. Shorten when necessary
- If side plates are fitted, the chain must be shortened if the chain becomes visible below the level of the side plates.
- The opening and closing of the links when they turn round the end drive and idler wheels could be a risk. Drive and idler ends should not be accessible during conveyor operation wherever possible.

The area near the in-feed guides for the chain return loop should not be accessible during conveyor operation.

2.2.1.2 *Intermediate drive units*

- The area near the in-feed guides for the chain return loop should not be accessible during conveyor operation.

2.2.1.3 *Horizontal bend drive unit*

- The drive wheel should not be accessible during conveyor operation. The bottom should be covered with wheel cover.

2.2.1.4 *Idler units*

- The opening between the links when they turn round the idler roller could be a risk. Idler ends should not be accessible during conveyor operation wherever possible.

2.2.1.5 *Wheel bends, horizontal and vertical*

- Guarding may be required at wheel bends depending on location of bends and load applied to the conveyor.
- The opening between the links when they turn round the idler roller could be a risk. Idler ends should not be accessible during conveyor operation wherever possible.

2.2.1.6 *Cleated chains*

- Any application incorporating cleated chains requires careful safety consideration. Pinch and shear points are generated throughout the assembly of the incorporated components. Therefore generous guarding should always be employed to fully protect within user operating areas.
- There is a higher risk of product damage when using cleated chains. Special attention must be given to operator access in the event of products becoming trapped or similar.

2.2.1.7 *Maintenance*

The maintenance routine of FlexLink conveyors should also include procedures to ensure that the guarding remains securely fastened and effective (if not interlocked via control system etc.).

FlexLink components are continuously reviewed to improve performance either by design modification or material upgrade. In all these reviews user safety is our primary consideration.

All associated technical data are retained at the manufacturers address.

2.2.1.8 *Control system*

Before operating or completing any maintenance on control system, read the associated section as supplied with the equipment documentation.

If there are any questions as to the safe operating procedures of the equipment supplied, please contact FlexLink immediately.

- Follow the instructions in this user manual when transporting the machine. FlexLink AB must approve all modifications or changes to this machine.
- Only use recommended spare parts.
- Only authorised personnel may open electrical units.
- FlexLink is not responsible for damage if service on the equipment is not performed in accordance with this user manual.

2.2.2 Maintenance and Service technicians

Service technicians must have:

- Sufficient knowledge for reading technical information
- Ability to comprehend technical drawings
- Basic knowledge of mechanics
- Sufficient knowledge in the use of hand tools
- Skilled (EN ISO 12100:2010)

2.2.3 Electricians

Electricians must have:

- Experience from similar installations
- Sufficient knowledge to work from drawings and wiring diagrams
- Knowledge of local safety regulations for electrical power and automation
- Skilled (EN ISO 12100:2010)
- To avoid risks, only experienced personnel with technical knowledge and experience may perform repair work on the machine's electronics components.

2.2.4 Operators

To correctly use the equipment, operators must have appropriate training and/or experience.

3 Maintenance

3.1 System maintenance

3.1.1 Introduction

The following section is designed to offer assistance for your planned maintenance schedule. It may become evident that the suggested maintenance intervals can be extended to accommodate your local environmental conditions.

Maintenance of the FlexLink conveyor systems should only be carried out by competent persons, who are familiar with FlexLink equipment. If there is any doubt as to the most suitable procedure for maintenance, consult your FlexLink supplier.

3.1.2 Non FlexLink equipment

Equipment and components which are not from the FlexLink family of products should be maintained and serviced in accordance with their respective manufacturer's instructions.

3.1.3 Safety considerations

Before starting any maintenance on your FlexLink equipment, the following safety instructions must be observed:

- All electricity must be switched off.
- Make sure that the motor switch is also switched off and locked in the "off" position.
- Pneumatic and/or hydraulic power must be disconnected and any pressure accumulation released.
- Products being transported should, if possible, be removed from the conveyor chain.
- Staff affected must be informed that maintenance work is being undertaken.

Warning: *Do not climb onto the equipment.*

3.2 Maintenance instructions

3.2.1 Introduction

This maintenance manual contains directions for the standard components sold through the FlexLink main catalogue, for conveyor systems XS, XL, XM, XH, XK, and XB unless otherwise stated. For non-FlexLink components, such as motors, pneumatic equipment, control systems etc., the manufacturer's maintenance instructions apply. In general, maintenance instructions are not given for equipment which the customer has chosen and specified for fitting to the installation.

The instructions supplied should be followed to ensure that the installation runs with a high degree of safety and to minimize the risk of breakdowns which can adversely affect the production.

The installation must be used for the transport of goods in accordance with system specification or within design criteria as outlined in the general catalogue. If a fault occurs on the installation which cannot be rectified with the help of the instructions in the manual, or if unexpected conditions occur during servicing, contact your FlexLink retailer or FlexLink maintenance personnel.

3.2.2 Warranty/guarantee

FlexLink conveyors are covered by warranty/guarantees as identified within the trading terms issued for each country. Check the warranty conditions for your system before submitting claims etc. If you are in any doubt as to what warranty is applicable to your system, consult your supplying agent or FlexLink Systems direct.

3.2.3 Spare/replacement parts

If there is a demand for spare parts, contact FlexLink Systems or your supplying agent.

3.2.4 Checklist/maintenance schedule

A suggested maintenance schedule is shown on page 36.

3.2.5 Important

Consult your system documentation for any special maintenance required for your specific installation.

3.3 Introduction to drive units

3.3.1 Four types

There are four different types of drive unit: end drive units, intermediate drive units, catenary drive units and horizontal bend drive units.

3.3.1.1 *End drive units*

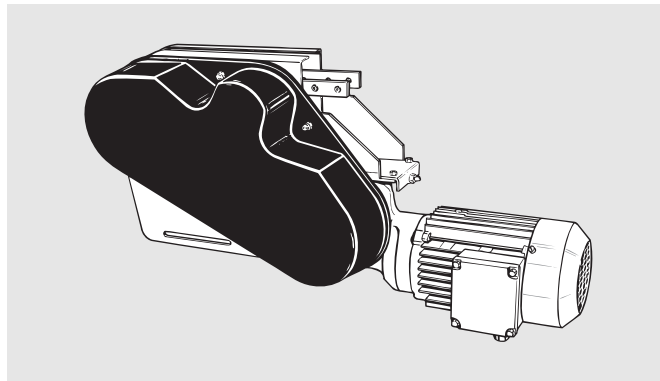

End drive unit with return chain, located at the 'pulling' end of the conveyor. End drive units are either transmission chain types (see picture) or direct drive types.

3.3.1.2 *Intermediate drive units*

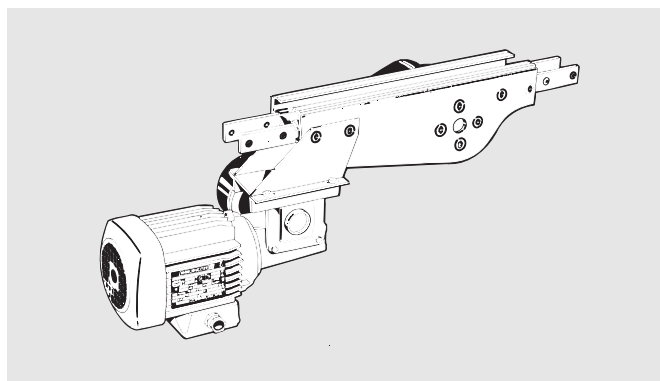

Intermediate drive unit located at an intermediate position along the conveyor.

3.3.1.3 *Catenary drive units*

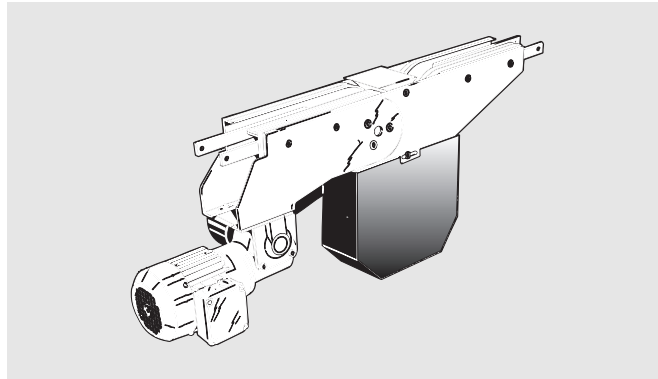

Catenary drive unit without return chain, located at an intermediate position along the conveyor.

3.3.1.4 *Horizontal bend drive units*

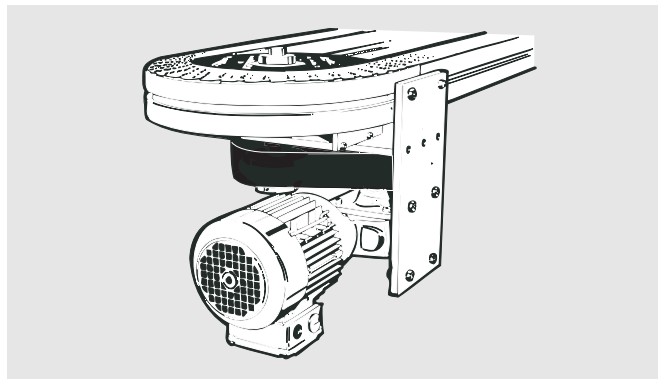

Horizontal bend drive unit for driving endless conveyors without return chain.

3.3.1.5 *Chain transmission*

The drive units are normally fitted with roller chain transmission. Some end drive units come with direct drive.

NB: The roller chain transmission has chain guards and gearing protection. These guards should always be in position when the conveyor is in operation.

3.4 Slip clutch adjustment

3.4.1 Old and new versions

The slip clutch is available in two versions. Shipping of the new version began in 2001. Adjustment of both versions are described here.

3.4.2 Introduction

The slip clutch on the drive unit is a safety device which allows the chain to stop if the load becomes excessive. It has two purposes:

- Prevent damage to conveyor
- Prevent damage to the products on the conveyor

Where a slip clutch is fitted, it must be adjusted so that it does not slip whenever the drive unit is started under full load. The installation is carried out as follows:

Preparations for adjustment

- Stop the conveyor.
- Ensure that the conveyor can not be started accidentally. For example: unplug the electric power plug.
- Remove any load on the conveyor.

Caution:



If you try to adjust the slip clutch when there is still load on the conveyor, the accumulated tension in the chain can cause severe injuries when you release the clutch.

Slip clutch should not be adjusted until

- Motor direction is confirmed
- Conveyor is fully assembled

Important:



The slip clutch is not a personal safety device. It is primarily intended to protect the equipment.

3.4.2.1 Clutch adjustment, old type

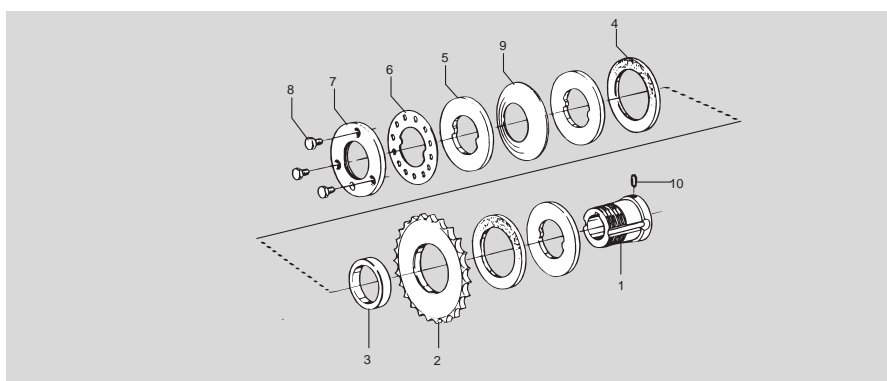

- 1 Remove the transmission cover.
- 2 Unscrew the three screws (8) so that the outer ring (7) can be rotated freely.
- 3 Hand-tighten the outer ring (7) to stop (no tools!).
- 4 Look for the desired maximum traction force in the table to the right and determine the X value for that force.
- 5 *Positive X-value: (If the X value is negative ($X \leq 0$) ignore step 5 and go to step 6.)* Turn the outer ring (7) counter-clockwise the number of divisions given by the table, i.e. the X value. One division is defined as the angle (30°) between adjacent holes in the stop ring (6). Check that screws (8) align with the holes in the stop ring (6).
- 6 *Negative X-value: (If the X value is positive ($X \geq 0$) ignore step 6 and go to step 7.)* Turn the outer ring (7) clockwise with a hook wrench, the number of divisions given by the table, i.e. the X value. One division is defined as the angle (30°) between adjacent holes in the stop ring (6). Check that screws (8) align with the holes in the stop ring (6).
- 7 Tighten the three screws (8) to stop. Use 10 mm wrench

3.4.2.1.1 Clutch adjustment table, old type

F_{\max} is the desired maximum traction force applied to the chain by the drive unit. The clutch will start slipping at forces above F_{\max} .

NB: The values in the table are approximate and apply to factory-new slip clutches

Traction force F_{max} (N)			X (div.)	Traction force F_{max} (N)			X (div.)
XS XL	XM XH XW	XK		XM XH	XW XK	XK	
450	450	100	19	1200	1200	1400	6
475	475	200	18		1300	1500	5
	525	300	17		1400	1600	4
	575	400	16		1525	1700	3
	625	500	15			1800	2
	675	600	14			1900	1
	725	700	13			2000	0
	775	800	12			2100	-1
	825	900	11			2200	-2
	875	1000	10			2300	-3
	925	1100	9			2400	-4
	1000	1200	8			2500	-5
	1100	1300	7				

3.4.2.2 Clutch adjustment, new type

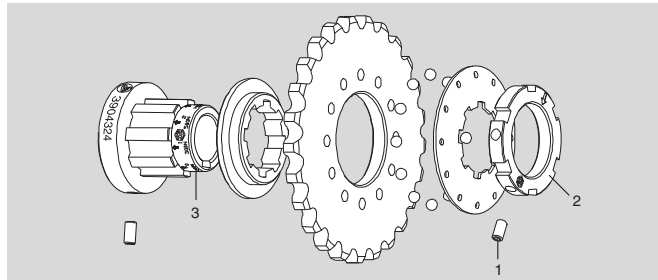

- 1 Remove the drive unit protection cover.
- 2 Use an Allen key, 3 mm, to loosen the screw (1) on the slip clutch so that the adjustment nut (2) can be freely rotated.
- 3 Turn the adjustment nut (2) clockwise with a hook spanner until the arrow on the nut is aligned with the desired F_{max} value (3). See the following table for correct values.
- 4 *Note:* On delivery, the clutch is always set to "0".
- 5 Tighten the screw (1).
- 6 Re-install the drive unit protection cover.

3.4.2.2.1 Clutch adjustment table, new type

F_{\max} is the desired maximum traction force applied to the chain by the drive unit. The clutch will start slipping at forces above F_{\max} .

XS XL	Traction force, F_{\max} (N)			No.
	XM, XH XK, XB	XT	XK H	
300	300	300	600	0
400	400	400	800	1
500	500	500	1000	2
	700	700	1150	3
	800	800	1300	4
			1550	5
	1050	1050	1700	6
	1250	1250	2000	7
				8
		1400	2200	9
				10
				11
		1500	2400	12
				13
		1650	2500	14
Standard and direct drives 1/2": Slip clutches marked 3904324, 5052769, 3925774, 5052827			Standard drives 5/8": Slip clutches marked 3925071, 5052772	



1 Hook spanner

3.5 Inspection – drive units

3.5.1 Roller chain transmission

The roller chain transmission should be checked and lubricated after 50, 250, 500 hours of operation, and then every 500 hours.

If the roller chain transmission is not fitted with a chain tensioner the chain tension should be checked on this occasion.

At the same time as the roller chain tension is checked, the chain must also be lubricated with a suitable chain spray or similar.

If the transmission is fitted with a chain tensioner, lubrication should only be carried out at the stated intervals. The condition of the chain tensioner must be checked at the same time as the lubricating is done.

NB: The discs in the slip clutch must be kept free from oil and grease.

3.5.2 Worm gear motor and geared motor

The worm gear or geared motor is checked in accordance with the instructions from the relevant supplier.

3.5.3 Guide for the conveyor chain

The purpose of the guide for the conveyor chain is to guide the return chain correctly into the drive unit.

Fully enclosed drive units do not have guides. On these, no slack is permitted at the drive unit since the conveyor chain is being controlled all the time. Special attention must be given to chain elongation in conveyors of this configuration.

If guides are fitted they can be of two different types:

- Loose disposable guides in plastic.

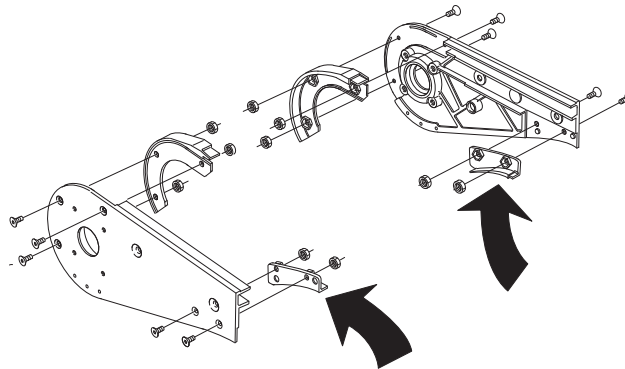

Replaceable chain guides

- Guides integrated into the ends of the drive unit.

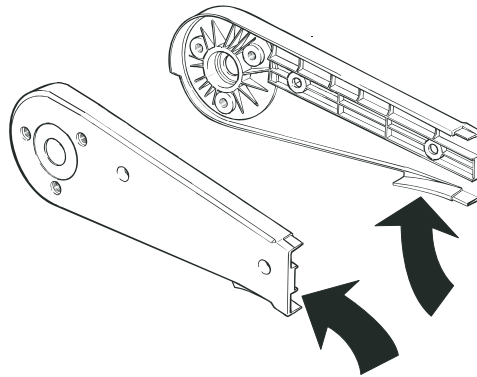

Chain guides integrated into ends

3.5.4 General checks on drive unit

Carry out a general inspection of the drive unit.

- Check particularly that the protective covers for the roller chains are complete and firmly in place.
- Replace damaged/worn parts.

3.6 Inspection – conveyor chains

3.6.1 Conveyor chains

The most common types of conveyor chains are:

- Plain conveyor chains.

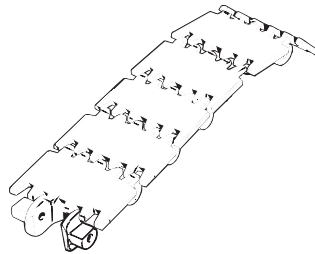

- Chain with cleats for inclined or vertical conveyor sections. The cleats are generally spread over the chain at a predetermined distance.

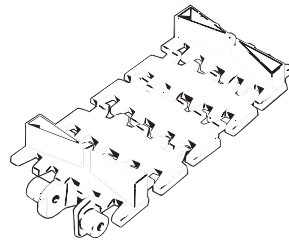

- Chain with flexible cleats for vertical wedge conveyors.

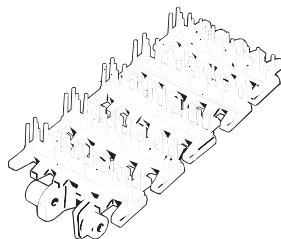

- Chain with friction surface for conveyors with an incline up to 30°. The friction surfaces are normally distributed over the chain at a predetermined distance.

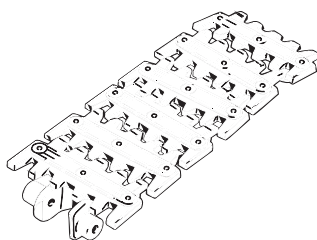

3.6.1.1 *Cleated, friction and wedge chains*

Cleated chains, friction chains and wedge chains, or other special chains should be inspected regularly, and any defective links replaced or cleaned.

Warning: Only warm water (50°C), with soap if necessary, may be used for cleaning conveyor chains.

- Check the guards on cleated chain conveyors.

3.6.2 Checking the tension of conveyor chain

The chain is made of elastic material. The chain eventually stretches as the material creeps. The extent of the stretch depends on the traction force in the chain. The stretch shows itself as slack on the return side of the drive unit.

The tension of the conveyor chain should be checked after 50, 250, 500 hours of operation and thereafter every 500 hours.

In operation there will be some slack in the conveyor chain. How much slack is acceptable depends on the length of the conveyor chain. The most suitable places to check the slack in the chain are at intermediate or end drive units.

3.6.3 Important:

The chain should therefore be pre-tensioned while the conveyor is stationary, but must never be so tight that there is no slack during operation. There should be no appreciable slack on the chain when the conveyor is stationary. This can, however, vary depending on the total length of the chain. If there is too much slack, there will be excessive wear on the chain guides and the chain. This could be a risk for injury.

If the slack on the conveyor chain is unacceptably high, it must be shortened by splitting the chain and removing the necessary number of links. See [Shortening conveyor chains on page 20](#).

If the conveyor has a guided drive unit with no chain slack take up, the elongation of the chain has to be monitored even more carefully, to ensure a trouble free operation.

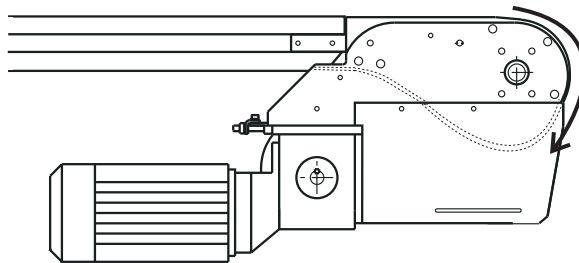

The conveyor chain must show some slack during operation.

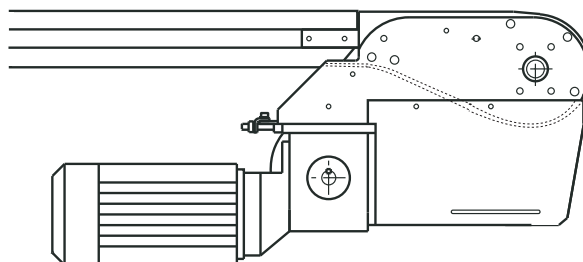

The conveyor chain does not need to show any slack when the conveyor chain is stationary.

3.6.4 Shortening conveyor chains

The most suitable place to shorten the chain is at the drive unit.

Alternatively:

- at a beam section for chain installation which has detachable sections.

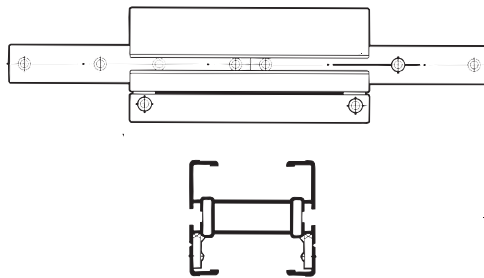

Beam section for chain installation

- by removing the side plates of the drive or idler end unit in closed systems.
- at a wheel bend by removing the outer curve.
- at a conveyor beam section for liftable chain (if there is any).

3.6.4.1 Instructions

- 1 Make the conveyor chain accessible at some of the overhead positions.
- 2 Remove the steel pin (1) from the pivot (2). Use the pin insertion tool (see figure).
- 3 Remove the necessary number of links.

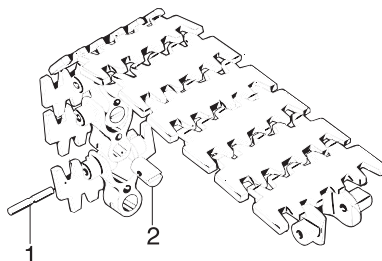

Chain joint components

NB: With cleated or friction chains, pay attention to the divisions between the links.

- 4 Join the chain together with a new pivot.

NB: The old pivot should not be re-used. When the chain is divided, a new pivot must always be fitted.

- 5 Insert the steel pin using the pin insertion tool.
- 6 After inserting the steel pin, check that it is centered and that the chain easily bends in the fitted link.

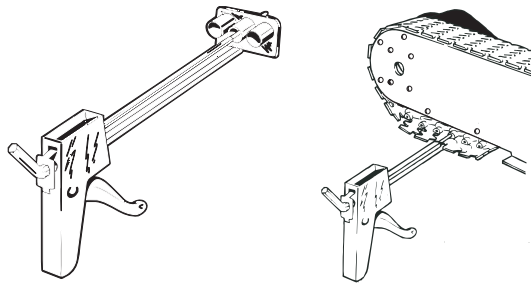

Usage of pin insertion tool

3.7 Inspection – slide rails, beams, idlers, bends

3.7.1 Checking slide rails

The condition of the slide rails is fundamental to the functioning of the installation. It is therefore essential that these are in good condition.

3.7.1.1 *Checking the slide rail with the conveyor chain in place*

The slide rail must be checked after every 250 hours' operation. Carry on the checking on a stationary conveyor with the chain in place.

- Check the fastening points on the slide rail.
- Check the joints on the slide rail.

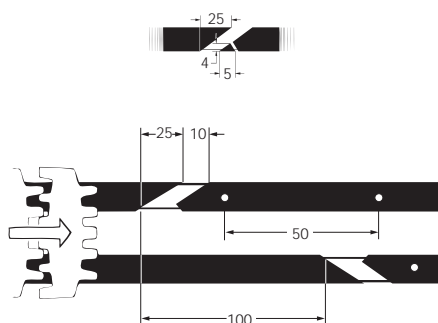

Correct configuration of joints

- Check that there is a gap between the slide rails and that the joints are correctly fitted.
- Check that the joints are not deformed.

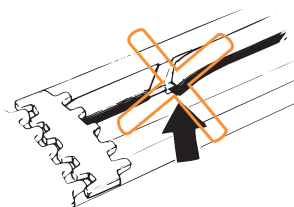

Deformed joints

- Check that the slide rail has not been broken off.

Replace the slide rail if necessary, see "Replacing the slide rail", beginning on page 27.

3.7.1.2 *Checking the slide rail, conveyor chain removed*

At least once a year or after every 2 000 hours' operation, the chain should be removed from the beam, and the slide rail carefully checked for wear and fastening.

Plain bends should be checked after every 500 hours' operation, since these are subjected to higher loads.

- Carry out the same checks as were carried out during "Checking slide rails with the conveyor chain in place".
- Check the slide rail for wear and tear.

NB: *Check in particular the inner slide rail in plain bends, since the stresses here are particularly high.*

- Check the slide rails for scratches and notches.
- Replace the slide rail and fasteners if necessary, see [Replacing slide rails on page 27](#).

Wash the conveyor chain.

3.7.2 *Conveyor beams, idler ends, and bends*

The conveyor beams themselves do not normally require any regular inspection. Be observant for damage arising from external factors, warping or deformation. Deformation can cause the conveyor chain to jam, resulting in uneven running.

Idler ends and wheel bends do not normally require any special inspections, but they should be checked when the slide rails are inspected.

Large radius plain bends may have inner support rails fitted to the beam. Ensure that these rails (if fitted) are not worn, paying particular attention to the "lead-in" area.

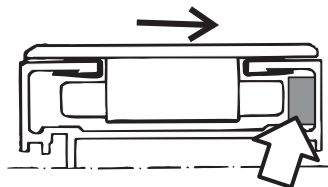

Inner support rails

3.8 Inspection – safety devices

Protective and safety devices

Safety devices should be checked at regular intervals.

- Check the chain guard for roller chain transmission. This guard must always be in place when the conveyor is in motion.
- Check the protective cover on the cleated chain conveyor return chain.
- Drive units type H, have a slack protection for the conveyor chain. Check that the slack protection plates are in place, and that the chain does not slacken enough to hang below the plates.
- Check the protective cover for the conveyor chain on intermediate drive units and catenary drive units.
- There may be other types of guard which are specific to your installation, and these must also be checked. See the system documentation.

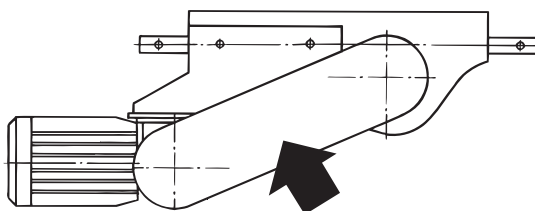

Chain guard for roller chain transmission

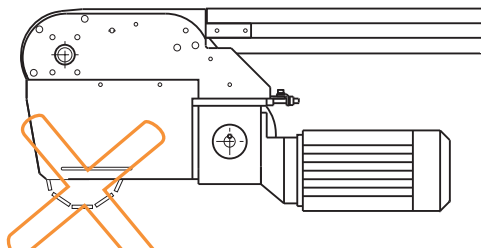

Slack protection plate for drive unit type H

3.9 Replacement of worn parts – conveyor chain

3.9.1 Removal of conveyor chain

- 1 Ensure that the power to the drive motor is disconnected.
- 2 Disengage the motor; there are various methods depending on the type of drive unit:
 - Detach the slip clutch.
 - Remove the roller chain.
 - Disengage the gear from the drive wheel.For more information see "Assembly manual", 5764.
- 3 Split the chain by removing the steel pin from the pivot. Use the special tool for insertion/removal.
- 4 Pull out the chain.

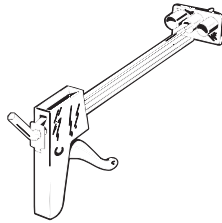

Pin insertion/removal tool

3.9.2 Fitting the conveyor chain

- 1 Run a sample (approx. 0.3 m) of conveyor chain through the installation in the direction of the conveyor. Check that the chain moves easily and correctly through the bends and idler ends. Check at the same time that there is enough space for the chain.

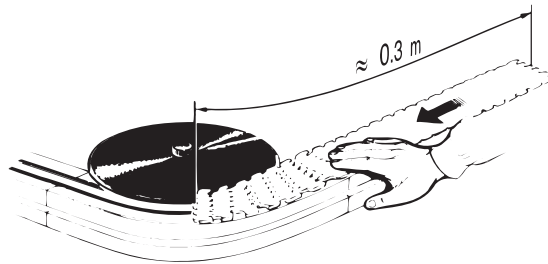

Sample for checking conveyor chain space

- 2 Put the new conveyor chain in place. Check that the chain direction corresponds to the conveyor direction.

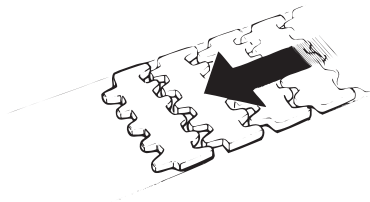

The conveyor chain direction

NB: *Be careful that the first link of the conveyor chain does not damage the slide rails.*

Immediately investigate the reasons for any jamming and take immediate action.

- 3 Shorten the conveyor chain to the right length. Fit the pivot and the steel pin, using the special pin insertion/removal tool.
- 4 After fitting, check that the steel pin is centered and that the chain can easily bend in the fitted link.
- 5 Check that the slack is not excessive. See [Checking the tension of conveyor chain on page 18](#).

3.10 Replacement of worn parts – slide rails

3.10.1 Replacing slide rails

It is very important to assemble slide rails correctly to ensure smooth system operation.

Follow the illustrated instructions on the following pages carefully. Observe the following points:

- Single-cut pliers are suitable tools for cutting the slide rails.



Single cut pliers

- Use mounting tool for slide rail XLMR 140, XMMR 140, XHMR 200, or XKMR 200.

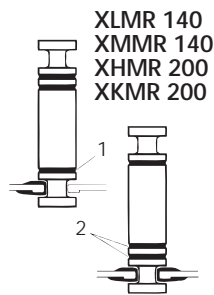

Mounting tool for slide rail

- Use drill fixture 3920500. The distance between anchor points must be 50 mm.

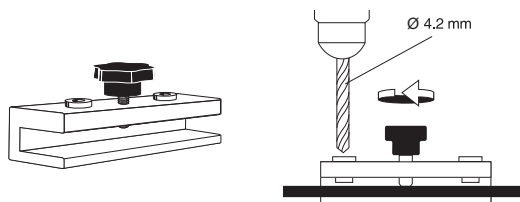

Drill fixture 3920500

- Use a high quality drill bit to avoid forming a shoulder, preferably one which is intended for drilling aluminium.
- Use XLAH 4x6/XLAH 3x6 rivets.
- When fitting the slide rails with rivets, the fitting instructions on page 29 must be followed.
- The joints on the slide rails must have a distance of 100 mm between them. The joints should be laid out as in the picture with a gap of approx. 10 mm between the rails.
- Joints may not be positioned in bends, or in the transition between two sections of beams.
- The slide rails should normally be approximately 5 m long on a straight conveyor beam. In a bend, the maximum length of slide rail should be 3 m.
- The joints should be positioned a minimum of 500 mm before an idler end unit, drive unit or vertical bend. The slide rail must overlap the recess in the idler end and drive unit.
- The inner slide rail after a wheel bend must be cut so that the cut surface is parallel to the wheel. In front of the wheel bend, the slide rail will normally be cut at 45°.

NB: Check the final slide rails visually, as well as running a section of conveyor chain through the installation.

An alternative to the aluminium rivets, is to use the plastic screws XLAG 5 (XWAG 5 for XK). See page 32 for fitting instructions. The holes for the plastic screws are threaded with a tap.

3.11 Anchoring slide rail

3.11.1 Fixing slide rail to the conveyor beam

Hand drill	
Drill fixture for slide rail	4,2 mm (XS: 3,2 mm)
Countersink	

The beginning of each slide rail section must be fixed to the beam, since the chain will cause the slide rail to be pushed forward. Slide rail which moves into a wheel bend or a drive unit can block the chain completely.

There are two different methods for fixing slide rail to the conveyor beam: using aluminium rivets or plastic screws. Either method can be used, but the riveting method is more secure if the conveyor will run with high operational speed or be heavily loaded.

After drilling, remove the drill fixture and countersink the holes so each rivet head is under the slide rail surface before riveting.

3.11.1.1 Method 1: Using aluminium rivets

Rivet crimping pliers/rivet crimping clamp
Aluminium rivets

3.11.1.1.1 Mounting



- 1 Insert rivets in the holes, using rivet crimping pliers or a rivet crimping clamp. For type of rivet, see table on previous page.



- 2 If working space is limited, the rivet crimping clamp might be easier to use. The two crimping tools perform the same task, but the pliers are more efficient and easier to use.

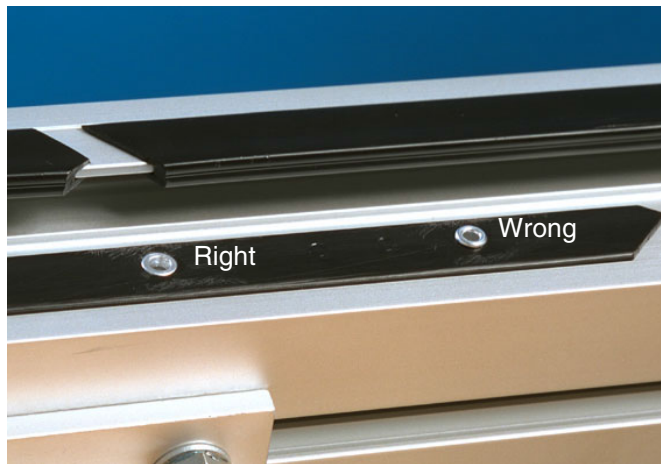

- 3 Check that the rivets do not protrude over the surface of the slide rail.
Check both top and underneath surface of slide rail for protruding metal

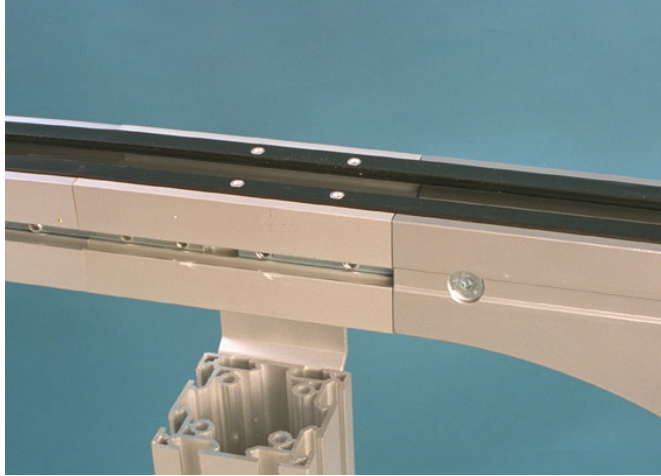

- 4 Keep a distance of approximately 30 mm between rivets and idler unit. This is in case the idler unit has to be removed after conveyor system assembly.

3.11.1.2 Method 2: Using plastic screws

Pliers/screwdriver	
Chisel	
Hammer	
Plastic screws	XLAG 5

An alternative to aluminium rivets is to use plastic screws XLAG 5

3.11.1.2.1 Mounting



- 1 Press or screw the screws into the holes using a pair of pliers or a screwdriver.



- 2 Cut off the screw heads by using a chisel and a hammer. The cut should be made away from the joint, in the direction of chain travel.



- 3 Make sure the slide rail surface is smooth and that screws do not protrude over the surface of the slide rail. If the surface should be uneven, file the edges smooth. Check both top and underneath surface of slide rail for protruding plastic or metal.

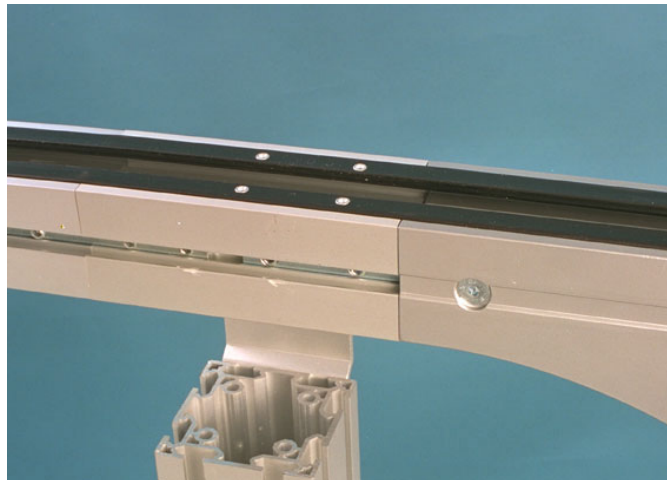

- 4 Keep a distance of approximately 30 mm between screws and idler unit. This is in case the idler unit has to be removed after conveyor system assembly.

4 Troubleshooting

4.1 Jerky running

Cause	Corrective action
Damaged or badly fitted slide rail	Inspect and replace as necessary.
Wrongly adjusted slip clutch	Check and adjust slip clutch.
Worn transmission parts	Check/replace transmission chain, chain drive sprocket.
Conveyor chain is too tight/loose	Tension conveyor chain correctly.
Dirty conveyor	Clean conveyor chain/slide rail. Lubricate with silicone based lubricant.

4.2 Drive unit is running, conveyor chain is not

Cause	Corrective action
Wrongly adjusted slip clutch	Check adjustment of slip clutch.
Friction discs in slip clutch are worn or contaminated	Check and replace if necessary.
Damaged/badly fitted slide rail	Check the free running of the conveyor chain.
Transmission products are not fitted	Check and fit.

4.3 Motor overheating on drive unit

Cause	Corrective action
Overloaded conveyor	Remove products from conveyor and test run. Check actual conveyor load against recommended loading.
Gearbox leaking oil	Check output shaft seal and area around motor/gearbox interface.
Dirty conveyor	Clean the conveyor chain with warm water (50°).

4.4 Noise

Cause	Corrective action
Worn or damaged bearings in drive unit	Check/replace drive unit.
Damaged/badly fitted slide rail	Check the free running of the conveyor chain, especially in slide rail joints.
Excessive conveyor speed	Lower speed.
	Check actual load against recommended loading.
Incorrect conveyor chain tension	Lengthen/shorten conveyor chain.

4.5 Abnormal wear on plastic parts

Cause	Corrective action
Overloaded conveyor	Remove products from conveyor and test run. Check the free running of the conveyor chain. Check actual conveyor load against recommended loading.
Ambient temperature too high	Check against recommended temperature for conveyor.
Chemicals in the environment are affecting plastic parts	Check in FlexLink main catalogue (section TR) for listing of incompatible chemicals.
Damage due to ingress of contaminate	Clean the system.
Particles, swarf etc.	Remove source of contamination.

5 Checklist/maintenance schedule

No	General checks	Number of operating hours/time interval				See page
1.	Check roller chain, sprocket, chain tension and lubrication of drive unit	50	250	500	Then every 500 hours	page 15
2.	Check/adjustment of slip clutch	Every 1 000 hours				page 11
3.	Check conveyor chain guides in drive units and idler ends	Every 1 000 hours				page 15
4.	Check tension of conveyor chain	50	250	500	Then every 500 hours	page 17
5.	Check slide rails	Every 250 hours				page 22
6.	Check slide rails, conveyor chain removed.	Every 2 000 hours, or at least once a year				page 22
7.	Check slide rails in plain bends.	Every 500 hours				page 22
8.	Check safety and security devices	At least once a year				page 24

6 System dismantling and disposal

6.1 Important safety precautions

6.1.1 Dismantling

Dismantling of the FlexLink conveyor system should be carried out by competent persons, who are familiar with the equipment being decommissioned.

In the absence of detailed information, every care should be taken to ensure that all items are securely retained during the decommissioning process. This is to ensure that the equipment remains stable and will not fall if left unattended.

If pneumatics or hydraulics are to be decommissioned, special attention should be given for the safe release of any accumulated pressure from within the circuitry. All reservoirs/accumulators must be depressurised prior to removal.

If there are any doubts as to the most suitable procedure for decommissioning, then consult the equipment supplier.

6.1.1.1 Conveyor system XS, XL, XM, XH, XK, and XB

To dismantle a FlexLink conveyor the following tools are required.

Ring spanners /10 mm and 13 mm size

Allen keys

Pin insertion tool XS/XL = XLMJ 4

Pin insertion tool XM = XMMJ 6

Pin insertion tool XH = XHMJ 6

Pin punch XK = XKMJ 8

Hammer

Drill to remove slide rail rivets

- 1 Remove any remaining product from the conveyor system.
- 2 Switch off all electrical power and disconnect all pneumatic and hydraulic feeds, including accumulators. Ensure that system is safe by shutting down all feed supplies or removing electrical fuses.
- 3 Remove the black transmission cover from drive unit to expose slip clutch and transmission drive chain.

- 4 The locking effect of the slip clutch can be removed by removing the transmission chain or by releasing the slip clutch (section in maintenance and service refers to slip clutch adjustment).
- 5 Remove the motor gear unit from the conveyor drive assembly. The motor gear unit may be fitted with an oil breather. Ensure that the oil from the gearbox cannot leak into the surrounding area when decommissioned. Oil should be drained from the gearbox and disposed of in accordance with local environmental regulations.
- 6 Remove guide rails and guide rail brackets etc.
- 7 Split the conveyor chain using the pin insertion tool and remove the conveyor chain. If removing conveyor chain from over head conveyor special attention should be given when removing the last few metres. The weight of the removed chain accelerates the removal from the conveyor beams and can cause injury when the last links exit the extrusion. The chain should always be removed in the conveyor working direction.
- 8 Unscrew the inner grub screws from the drive unit connector strips and remove drive end from the conveyor. Repeat for idler end unit.
- 9 Remove the slide rail on all sides of the conveyor extrusion. Remove the slide rail retaining fixings by drilling away the rivets or plastic screws and pulling away the slide rail from the aluminium extrusion profile.
- 10 Dismantle the conveyor extrusions from the support brackets. This should be done in a systematic manner, removing conveyor section by section. Where extrusions are joined by connecting strips, first untighten the retaining grub screws from the connection strips. It may be necessary to release the clamp effect of the connector piece by giving a sharp tap with a hammer.
- 11 Dismantle the conveyor support system into separate components.
- 12 Sort different materials ready for disposal. Include a list of the materials.

If other equipment is to be dismantled simultaneously with the FlexLink conveyor, attention should also be given to the interaction of the other equipment to the FlexLink conveyor. Pneumatic equipment should be removed from the conveyor before dismantling. Hydraulic equipment should also first be removed to assist dismantling and handling of the conveyor components during dismantling and disposal.

6.2 Recycle

Sort different materials ready for disposal. Recycle components in accordance with local regulations.



Material categories

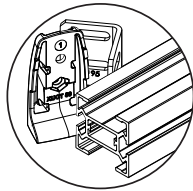

Aluminium

Beams, bends, support legs etc.

- Extruded aluminium

Brackets, feet etc.

- Die cast aluminium

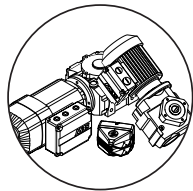

Electronics

Motors and all other electronics



Plastics

Chains

- Acetal resin

Slide rails

- HDPE, PA/PE, PVDF, UHMWPE

Guide rails

- PE, UHMVPE, PA

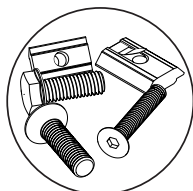

Steel

Fasteners

- Electro zinc plated steel



info@flexlink.com
flexlink.com