

# PRE-REQUISITES

Recommended tools

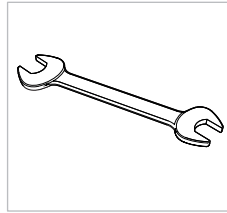

# SAFETY

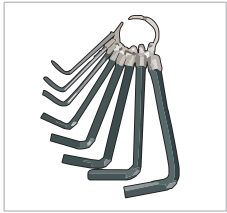

**WARNING**  
The system must not be operated without safety equipment properly mounted.



**WARNING**  
At installation, maintenance and service, make sure the motor is shut off.



**WARNING**  
Pinch Point

# PRODUCTS

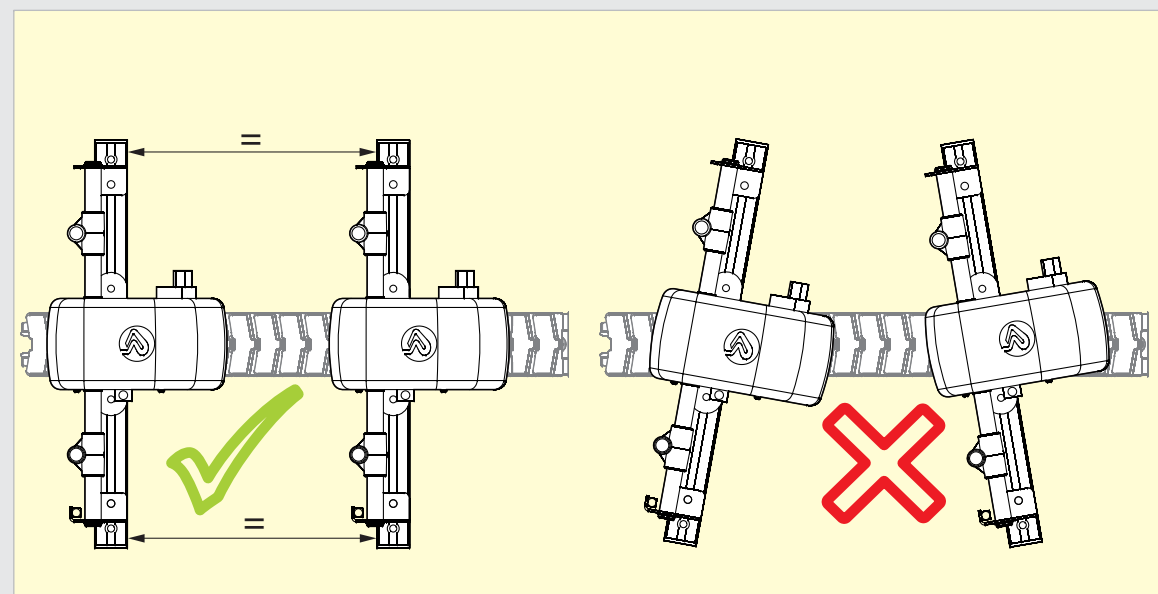
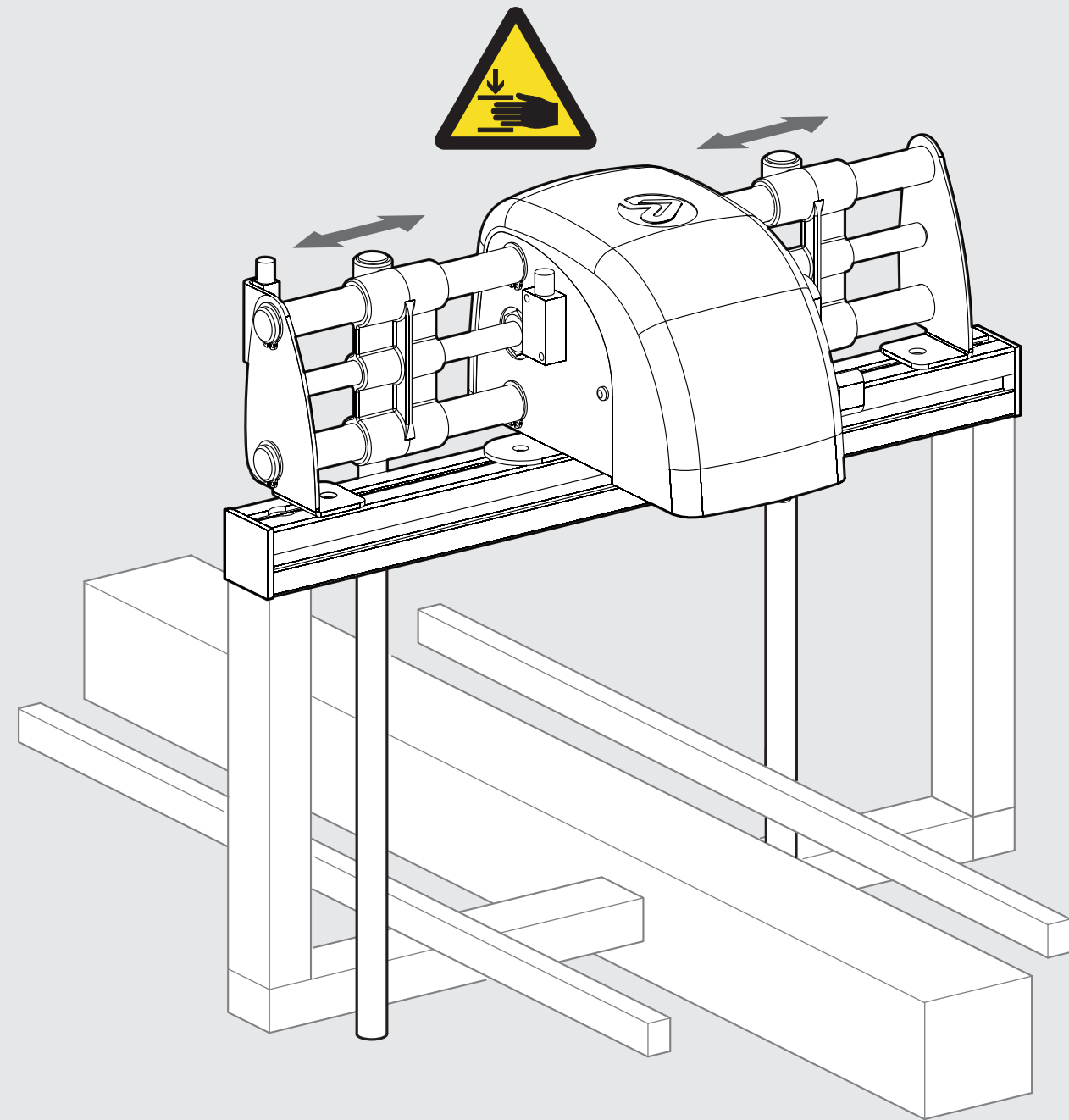
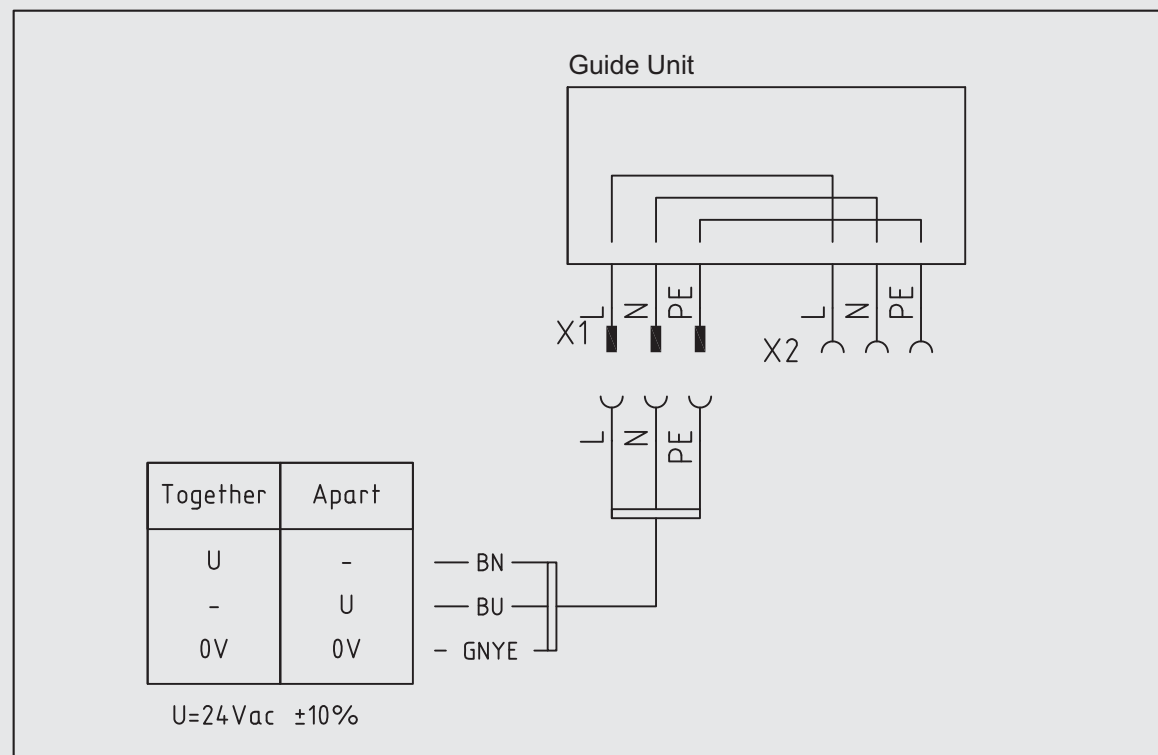
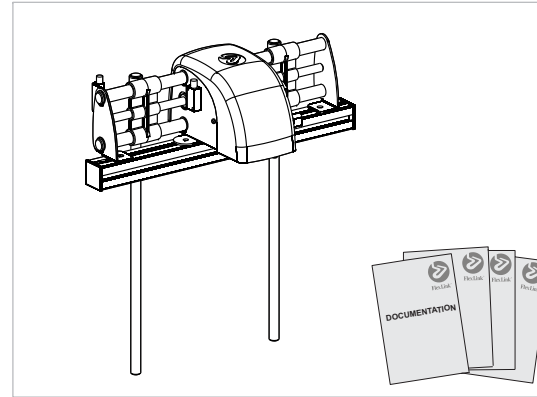

Basic value, Torque for dimension			
M5	M6	M8	M10
4 Nm / 35 lb. in.	9 Nm / 80 lb. in.	24,5 Nm / 217 lb.in.	45 Nm / 398 lb.in.

**FlexLink Components AB**  
SE-41550 Göteborg  
Sweden

We hereby declare that the following equipment is intended to be incorporated into a FlexLink conveyor system and thereby forming a machine. Operation is prohibited until it has been determined that the machine in which these products are incorporated, has been declared in conformity with the Machinery Directive 2006/42/EC, together with amendments which have entered into force as of the date of issue of this declaration, with particular reference to the essential health and safety requirements in connection with the design, construction and manufacture of the below specified equipment.

- Guide Unit, XLRQ 284x196 B, 455x196 B, 284x296 B, 455x296 B, 284x196 BF, 455x196 BF, 284x296 BF, 455x296 BF

# ASSEMBLY INSTRUCTION

## Guide Unit

XLRQ 284x196 B  
XLRQ 455x196 B  
XLRQ 284x296 B  
XLRQ 455x296 B  
XLRQ 284x196 BF  
XLRQ 455x196 BF  
XLRQ 284x296 BF  
XLRQ 455x296 BF

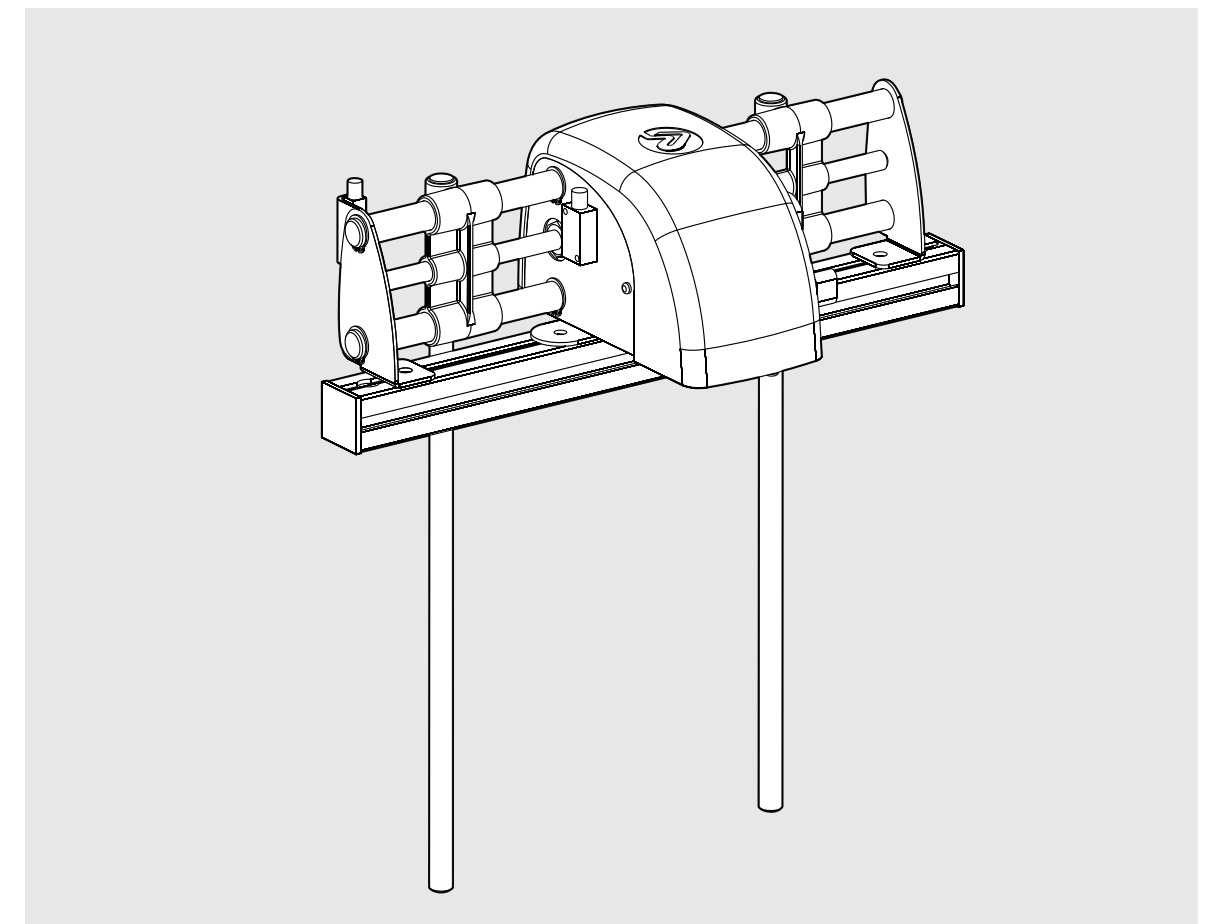

FlexLink Components AB



Svante Anderholm  
Chief Operating Officer

Flexlink Components AB



Anders Jonsson  
Responsible Technical file

FlexLink Components AB