

## Conveyor system XH

© Copyright FlexLink 2026

The contents of this publication are the copyright of the publishers and may not be reproduced (even extracts) unless permission is granted. Every care has been taken to ensure the accuracy of the information but no liability can be accepted for any errors or omissions. The right is reserved to make design modifications.

### Patents

Essential parts of the FlexLink product range are protected by patents and design regulations.

Drawings are made to European standards.

1. How to read the catalogue: Open the catalogue and from the Table of content or the PDF navigation bar locate the group in which the part you want to find is present. Turn over to the concerned page number by a "click". Now find out the figure of the part you wish to order. Jot down the part number against that particular figure number from the text. In case, if you have the part number and you need the other details, the part index can be used. The part index (at the end of the catalogue) will give you the figure and page number of the part you wish to order.

2. How to order spare parts: The part number and the description of the part required should be invariably mentioned in the order as per the catalogue text. The latest part number as conveyed through our service circulars should only appear on the order. In case of ordering colored components, colour code of the components should be mentioned. The quantity shown against the part number is the quantity per unit for that group so that particular quantity should be multiplied by the number of sets required.

3. Abbreviations: The following abbreviations are used in this catalogue:

assly.	Assembly
V	Volts
N.I.	Not illustrated
W	Watt
Comp.	Complete
Fr	Front
Std.	Standard
L	Length
A/t.	Alternate
Rr	Rear
L.H.	Left hand
R.H.	Right hand
AR	As required
<i>(Part number)</i>	Part number presented in "parantheses" and in Italic character style
*)	These items can only be purchased as part of a kit and when an item has an * the corresponding item always is placed between brackets (..) see above.
Recommended Spare part	Parts which are usually kept in stock and have short turnaround (See item 4)

4. Recommended Spare parts:

Several items of the complete spare parts overview are earmarked as recommended spare parts. FlexLink advises its cus-

tomers to purchase and stock these specific items for replacement in case of failure of the original item. The recommended spares are limited to only these items for which the cost of buying is in a fair relationship to the risk (i.e. probability \* impact) of sudden failure. It merely consists of wear parts and some electrical and pneumatic components.

## Content

<b>Spare parts End drive unit-XH</b>	<b>1</b>
End drive unit	2
End drive unit	3
End drive unit	4
End drive unit, type J	5
End drive unit	6
End drive unit, direct drive / direct drive guided	7
End drive unit, direct drive / direct drive guided	8
End drive unit, overhead motor	9
End drive unit, overhead motor	10
End drive unit, guided	11
End drive unit, guided	12
End drive unit, guided	13
<b>Spare parts Double drive unit - XH</b>	<b>15</b>
Double drive unit (c/c 106 mm)	16
Double drive unit (c/c 106 mm)	17
Double drive unit	18
Double drive unit (c/c 150-350 mm)	19
Double drive unit (c/c 150-350 mm)	20
<b>Spare parts Intermediate drive unit-XH</b>	<b>21</b>
Intermediate drive unit	22
Intermediate drive unit	23
Intermediate drive unit	24
<b>Spare parts Catenary drive unit - XH</b>	<b>25</b>
Catenary drive unit	26
Catenary drive unit	27
Catenary drive unit	28
Catenary drive unit	29
<b>Spare parts Horizontal bend drive unit - XH</b>	<b>31</b>
Horizontal bend drive unit	32
Horizontal bend drive unit	33
Horizontal bend drive unit	34
<b>Spare parts XHEB HNLN/HNRP</b>	<b>35</b>
Complete unit XHEB # HNLN/HNRP	35
0-unit XHEB 0 HNLN/HNRP	36
0-unit XHEB 0 HNLGP/HNRP	37
<b>Spare parts Idler end unit - XH</b>	<b>39</b>
Idler end unit	40
<b>Spare parts X_BH</b>	<b>41</b>
Complete wheel bend	41
<b>Spare parts Slide rails - XH</b>	<b>43</b>
<b>Spare parts Chains - XH</b>	<b>45</b>
<b>Spare parts Guide rail cover - XH</b>	<b>47</b>
Product designations in alphanumeric order	49

# Spare parts End drive unit-XH

Technical information from FlexLink



a coesia company

XH001-E9

## End drive unit- XH

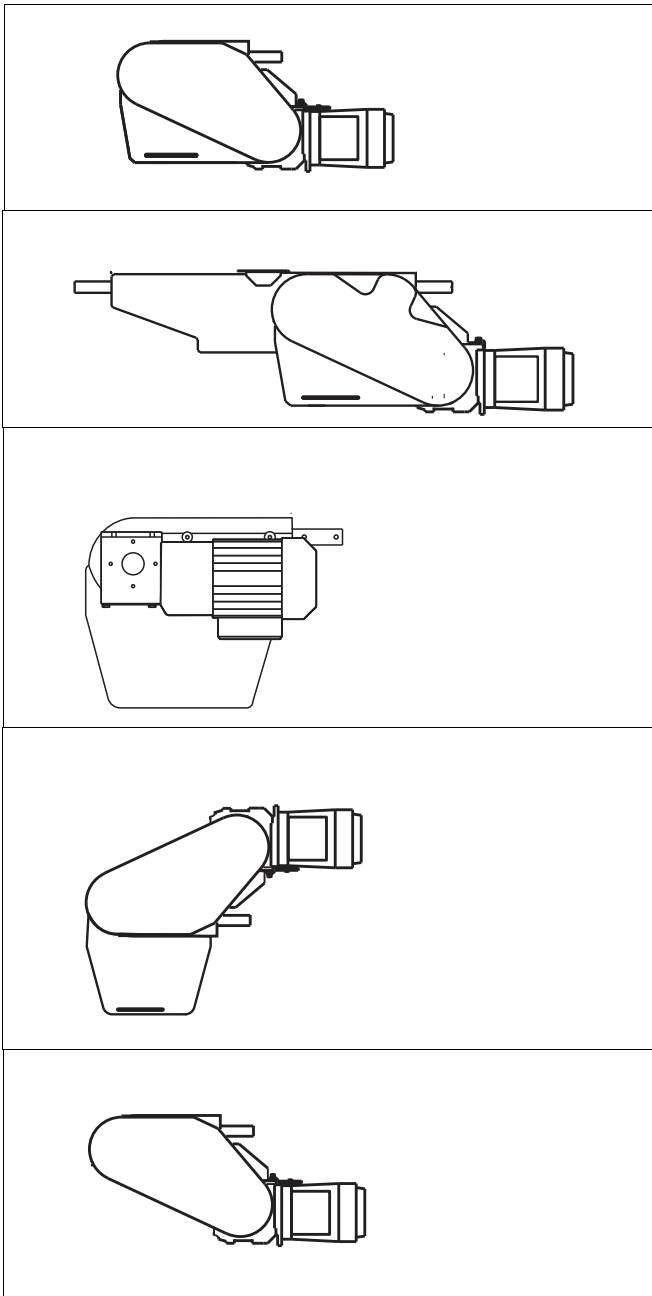

### Revision list

Document designation	Date	Type of revision	Entered by
XH001-E1	98-10-14	New version	Enator Inforum
XH001-E3	10-07-06	VP=>FM8 Added new column	JE
XH001-E5	19-12-09	Updated sprocket wheel table	ML
XH001-E6	21-05-03	Updated lists and logo	TG
XH001-E7	22-01-19	Side plates updated HLU/HRU & HLGU/HRGU	TG
XH001-E8	22-10-07	Removed comment on Basic unit item 3*.	IR
XH001-E9	24-12-13	Updated note for part 5117108	IR

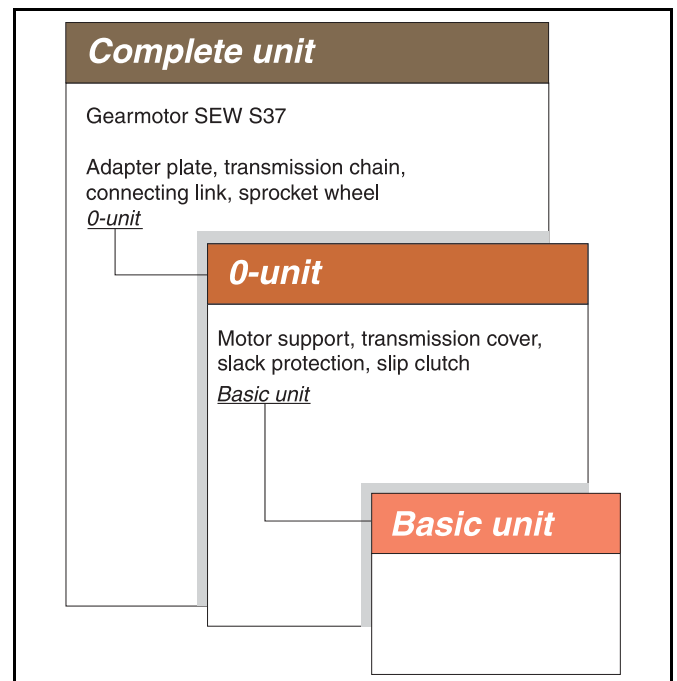

## End drive unit

Complete unit – XHEB \_HL/HR/HLA/HRA

For SEW S37 gearmotor

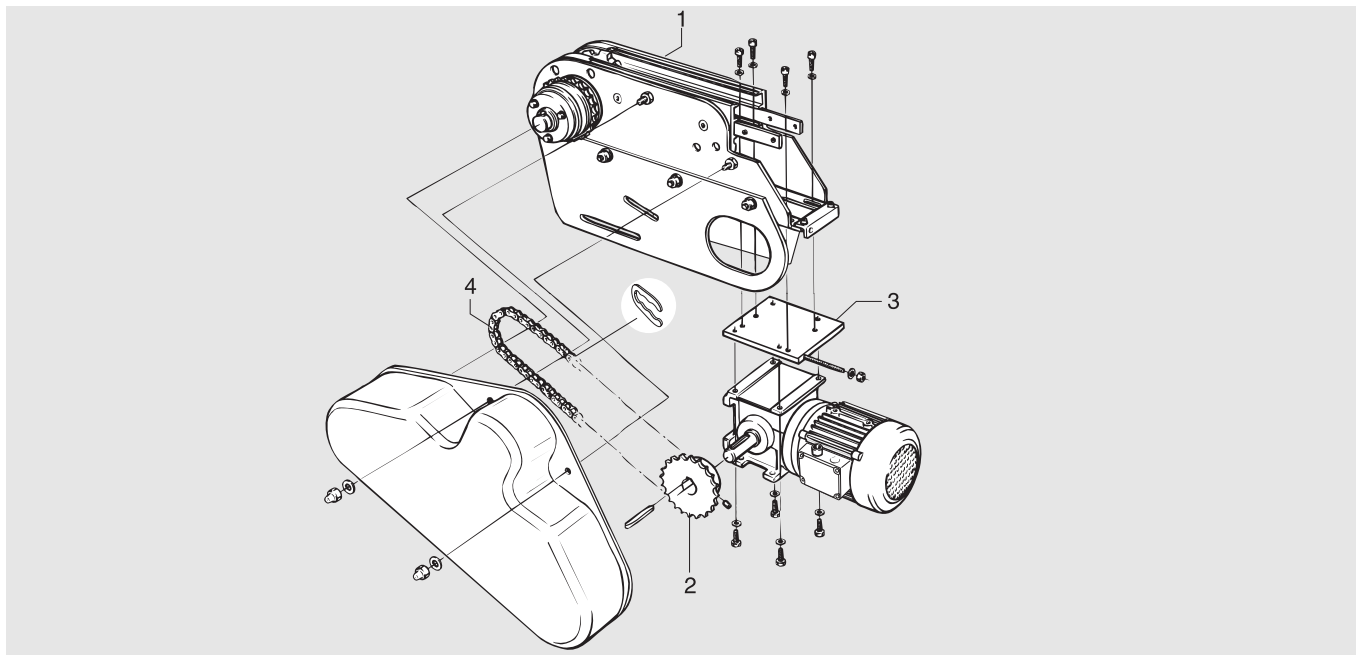

Item	Description	Part No	Qty	Comments	Recommended Spare parts
1	0-unit (left-hand version)	XHEB 0 HL/HLA	1	See next page for details	
	0-unit (right-hand version)	XHEB 0 HR/HRA	1	See next page for details	
2	Sprocket wheel 1/2" including grub screw		1	See table below	
3	Adapter plate including bolts and washers	3924197	1	For SEW S37 gearmotor	
4	Transmission chain 1/2" including connecting link	3921638	1	ISO/R- 1967- 08B- 1 (ISO)	X
	Transmission chain 1/2" including connecting link	5044948	1	ISO/R- 1967- 08A- 1 (ANSI)	X

## Important

Items 2-4 must be ordered separately when ordering a 0-unit (item 1). The sprocket wheel (item 2) should be specified in accordance with the following table:

Sprocket wheel 1/2"	Part No (SEW)	Shaft diameter
z=19 ISO	3924438	20
z=21 ISO	3924439	20
z=23 ISO	3924440	20
z=25 ISO	3921258	20
z=15 ANSI	5044935	19,05
z=17 ANSI	5044936	19,05
z=19 ANSI	5044937	19,05
z=21 ANSI	5044938	19,05
z=23 ANSI	5044939	19,05
z=25 ANSI	5044940	19,05

## End drive unit

## 0-unit – XHEB 0 HL/HR/HLA/HRA

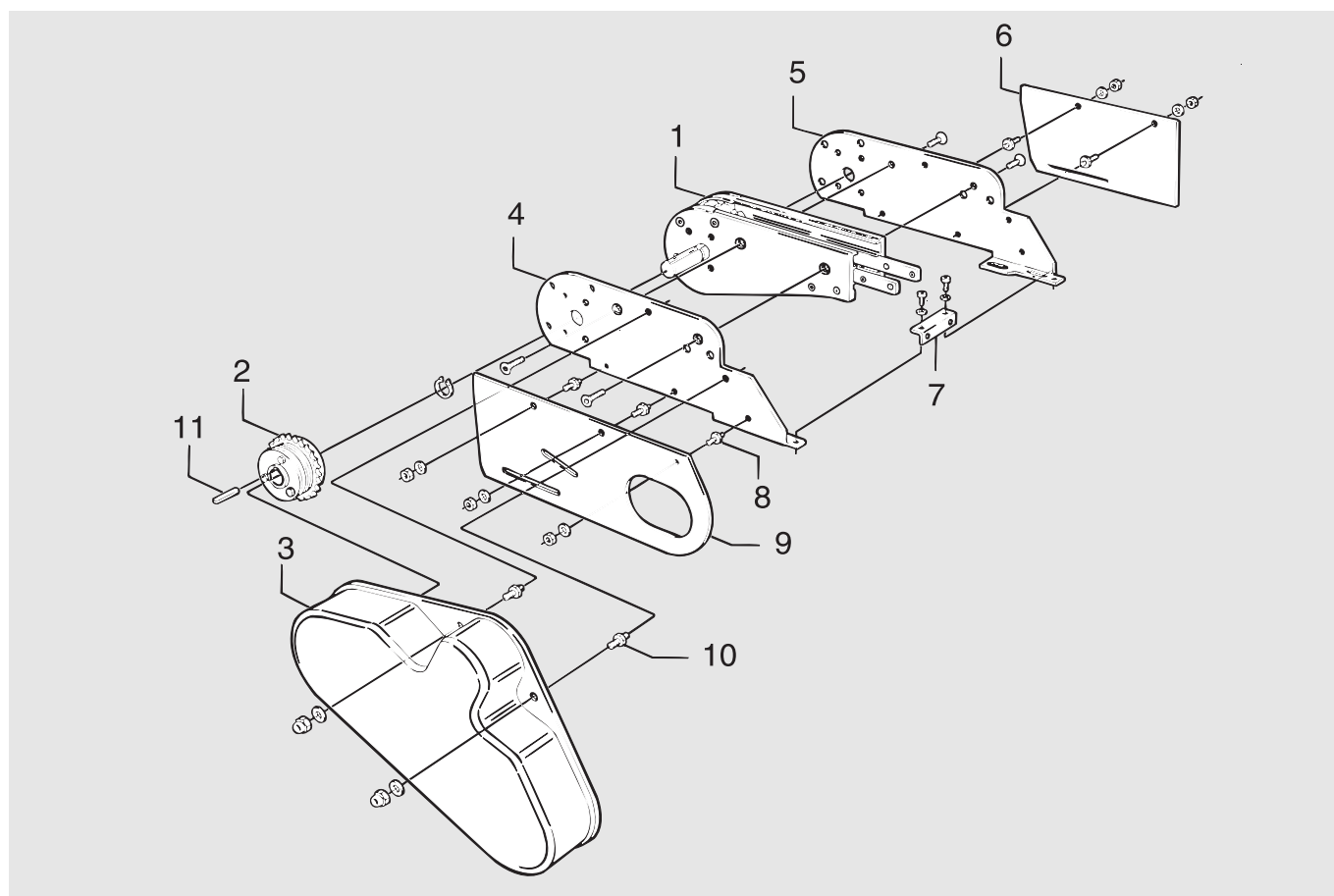

Item	Description	Part No	Qty	Comments	Recommended Spare parts
1	Basic unit (left-hand version)	XHEB 0 HLU	1	See next page for details	
	Basic unit (right-hand version)	XHEB 0 HRU	1	See next page for details	
2	Slip clutch Ø25 mm	5053981	1	ISO	
	-Slip clutch, Spare parts kit	5056817	1	ISO, incl. cup spring, ball, chain wheel.	X
	Slip clutch Ø25 mm	5054000	1	ANSI	
	-Slip clutch, Spare parts kit	5056820	1	ANSI, incl. cup spring, ball, chain wheel.	X
3	Transmission cover	3904431	1		
4	Motor bracket L	3904527			
5	Motor bracket R	3904528			
6*	Slack protection R	(3904665)	1	See kit below	
7	Adjusting block	3924287			
8*	Screw	(3904862)	5	See kit below	
9*	Slack protection L	(3904666)	1	See kit below	
10*	Screw	(3904855)	2	See kit below	
11	Thin parallel key	DIN 6885A h9	1	8×7×25	
*)					
6+9	Slack protection kit	5111566	1	LH+RH	
*) 8	Distance screw kit	5111600	1	Kit contains 10 pcs	
*) 10	Distance screw kit	5111599	1	Kit contains 10 pcs	

## End drive unit

## Basic unit – XHEB 0 HLU/HRU

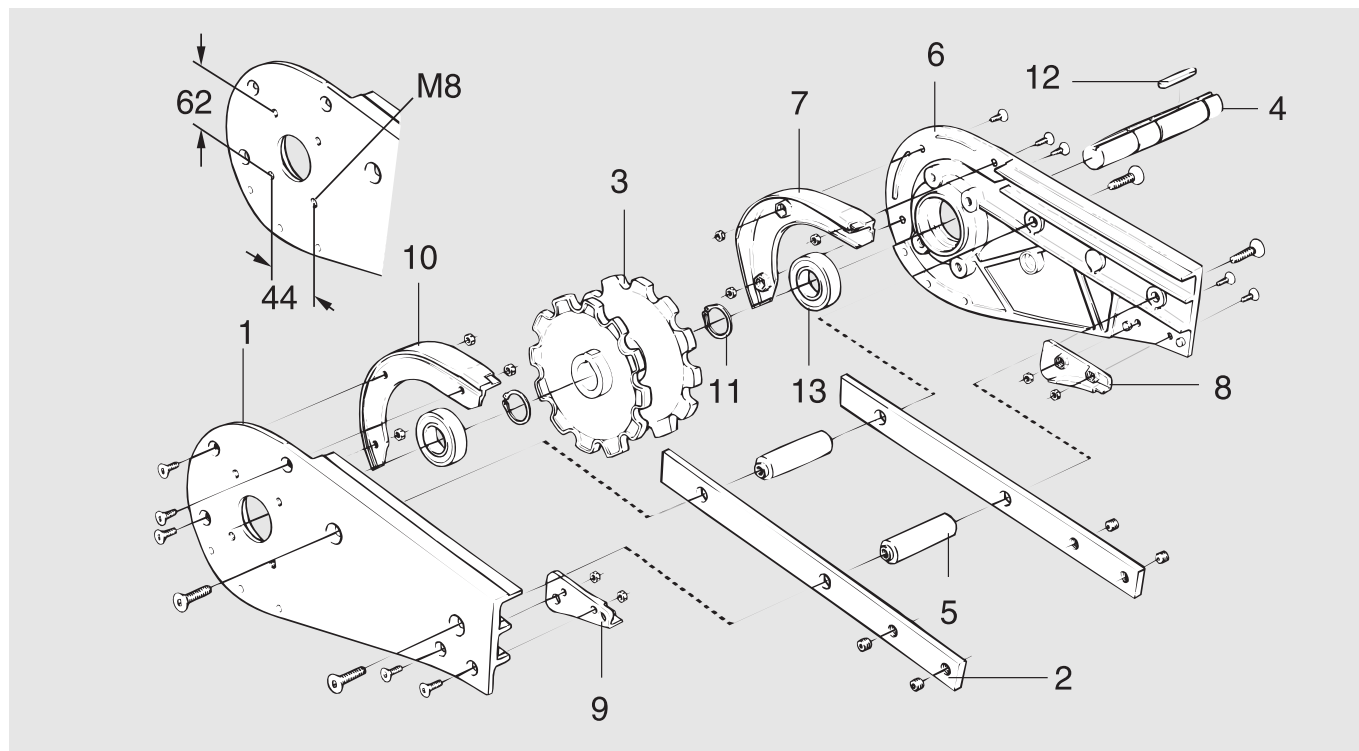

Item	Description	Part No	Qty	Comments	Recommended Spare parts
1*	Side plate L	(5130578)	1	See kit 5111628 below	
2	Connecting strip	3921123	2		
3*	Drive wheel	5111627	1	(3904299)	X
4*	Drive shaft	(3904403)	1		
5	Spacer	3904140	2		
6*	Side plate R	(5130506)	1	See kit 5111628 below	
7*	Steering guide R	(3904312)	1		
8*	Guide R	(3904313)	1		
9*	Guide L	(3904744)	1		
10*	Steering guide L	(3904745)	1		
11*	Retaining ring	DIN 471	3	25 st	
12*	Thin parallel key	DIN 6885	1	8×7×63	
13*	Bearing	(6205 2RS1/C3)	2		
<b>Kits</b>					
*1+6	Spare parts kit, Side plate	5111628			
*3+4+11 +12+13	Spare parts kit, Wheel	5111632			X
*7+10	Spare parts kit, Steering guide	5111629		LH+RH	X
*8+9	Spare parts kit, Guide	5111622		LH+RH	X

## End drive unit, type J

Complete unit – XHEB \_HLJ/HRJ/HLAJ/HRAJ

For SEW S37 gearmotor

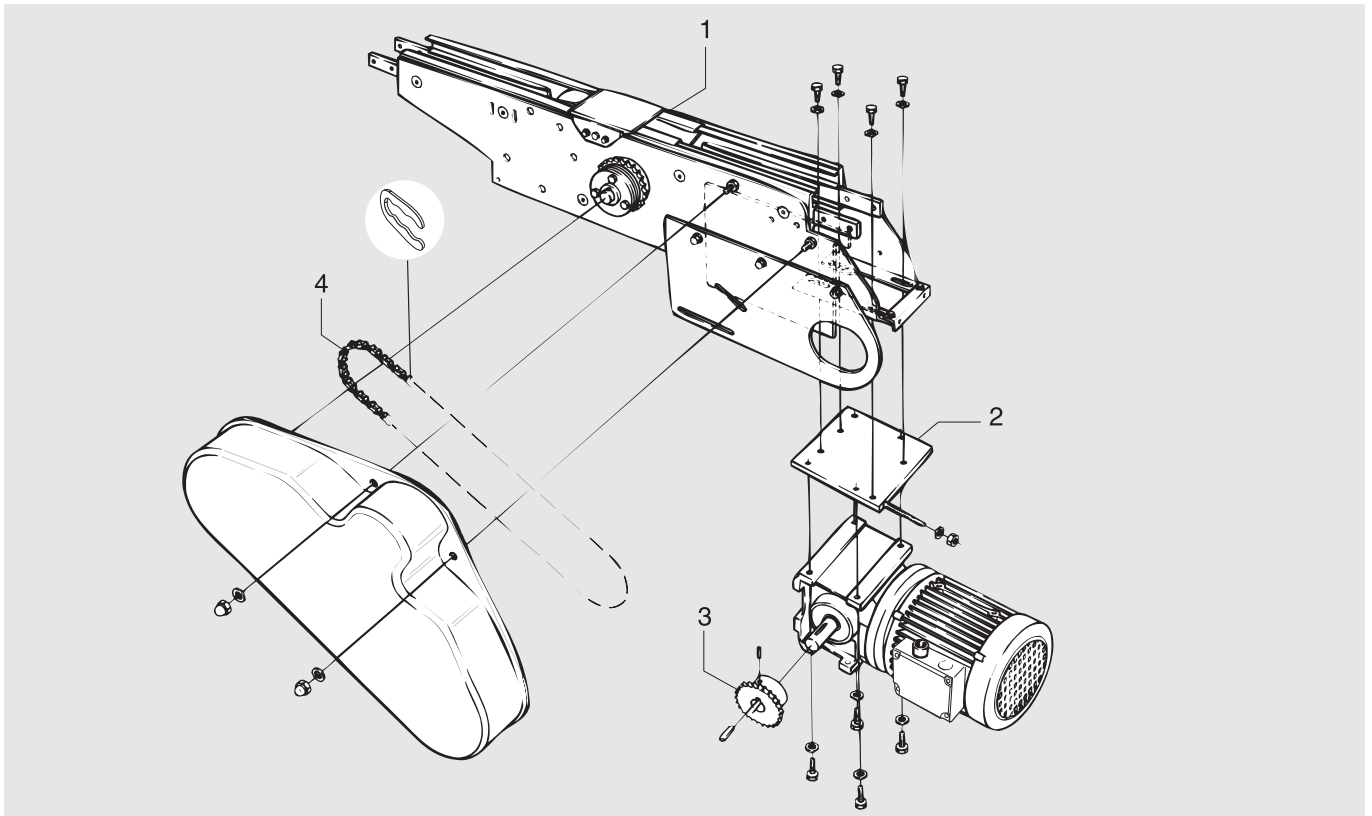

Item	Description	Part No	Qty	Comments	Recommended Spare parts
1	0-unit (left-hand version)	XHEB 0 HLJ/HLAJ	1	See next page for details	
	0-unit (right-hand version)	XHEB 0 HRJ/HRAJ	1	See next page for details	
	Motor alternative, see Drive unit guide 5014				
2	Sprocket wheel 1/2" including grub screw		1	See page 2	X
3	Adapter plate including bolts and washers		1	See page 2	
	Adapter plate		1	See page 2	
4	Transmission chain 1/2" including connecting link		1	See page 2	X
	Transmission chain 1/2" including connecting link		1	See page 2	X

## End drive unit

## O-unit – XHEB 0 HLJ/HRJ/HLAJ/HRAJ

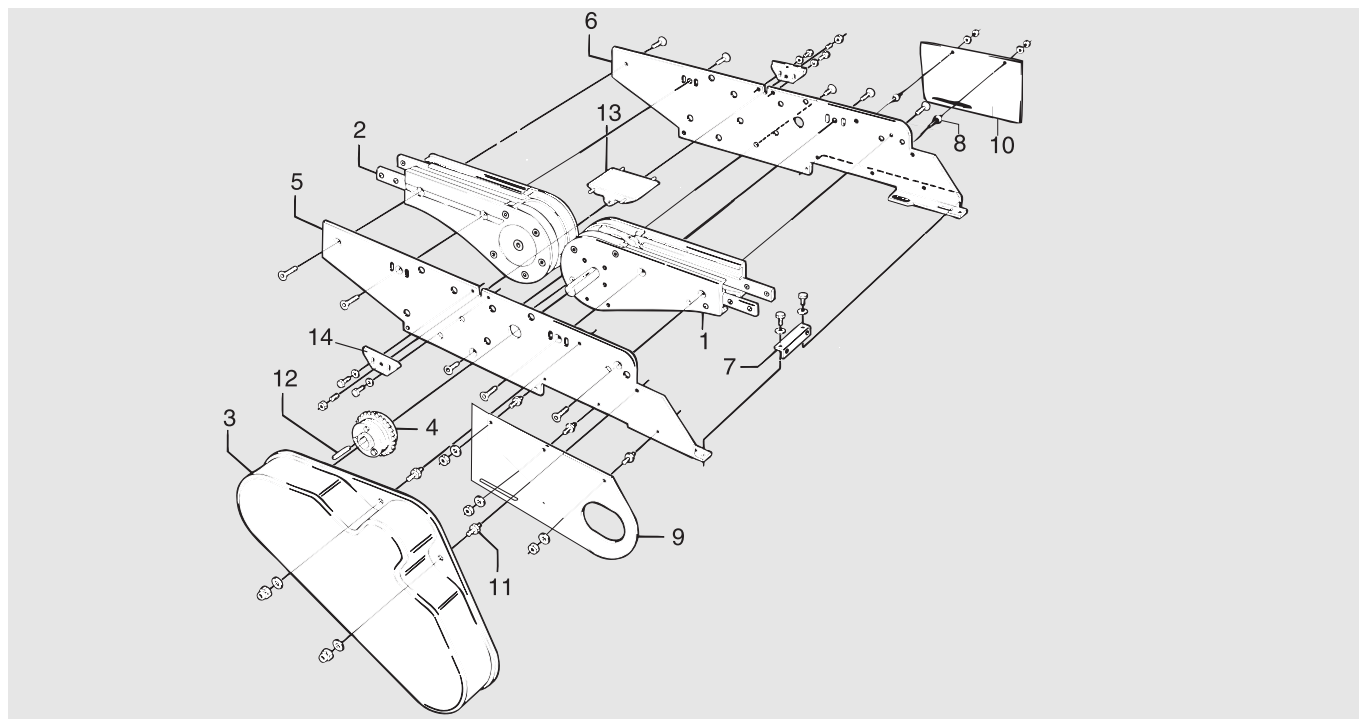

Item	Description	Part No	Qty	Comments	Recommended Spare parts
1	Basic unit (left-hand version)	XHEB 0 HLU	1	See next page 4 for details	
	Basic unit (right-hand version)	XHEB 0 HRU	1	See next page 4 for details	
2	Idler unit	XHEJ 325	1		
3	Transmission cover	3904431	1		
4	Slip clutch Ø25 mm	5053981	1	ISO	
	-Slip clutch, Spare parts kit	5056817	1	ISO, incl. cup spring, ball, chain wheel.	X
	Slip clutch Ø25 mm	5054000	1	ANSI	
	-Slip clutch, Spare parts kit	5056820	1	ANSI, incl. cup spring, ball, chain wheel.	X
5	Motor bracket L	3921463	1		
6	Motor bracket R	3921464	1		
7	Adjusting block	3924287			
8*	Screw	(3904862)	5		
9*	Slack protection L	(3904666)	1		
9*	Slack protection R	(3904666)	1		
10*	Slack protection R	(3904665)	1		
11*	Screw	(3904855)	2		
12	Thin parallel key	DIN 6885A h9	1	8×7×25	
13	Bridge	3905610	1		
14	Adjustment plate	3905278	2		
*) 9+10	Slack protection kit	5111566	1	LH+RH	
*) 8	Distance screw kit	5111600	1	Kit contains 10 pcs	
*) 10	Distance screw kit	5111599	1	Kit contains 10 pcs	

## End drive unit, direct drive / direct drive guided

Complete unit – XHEB HLP/HRP/HLGP/HRGP

For SEW SA 37 gearmotor

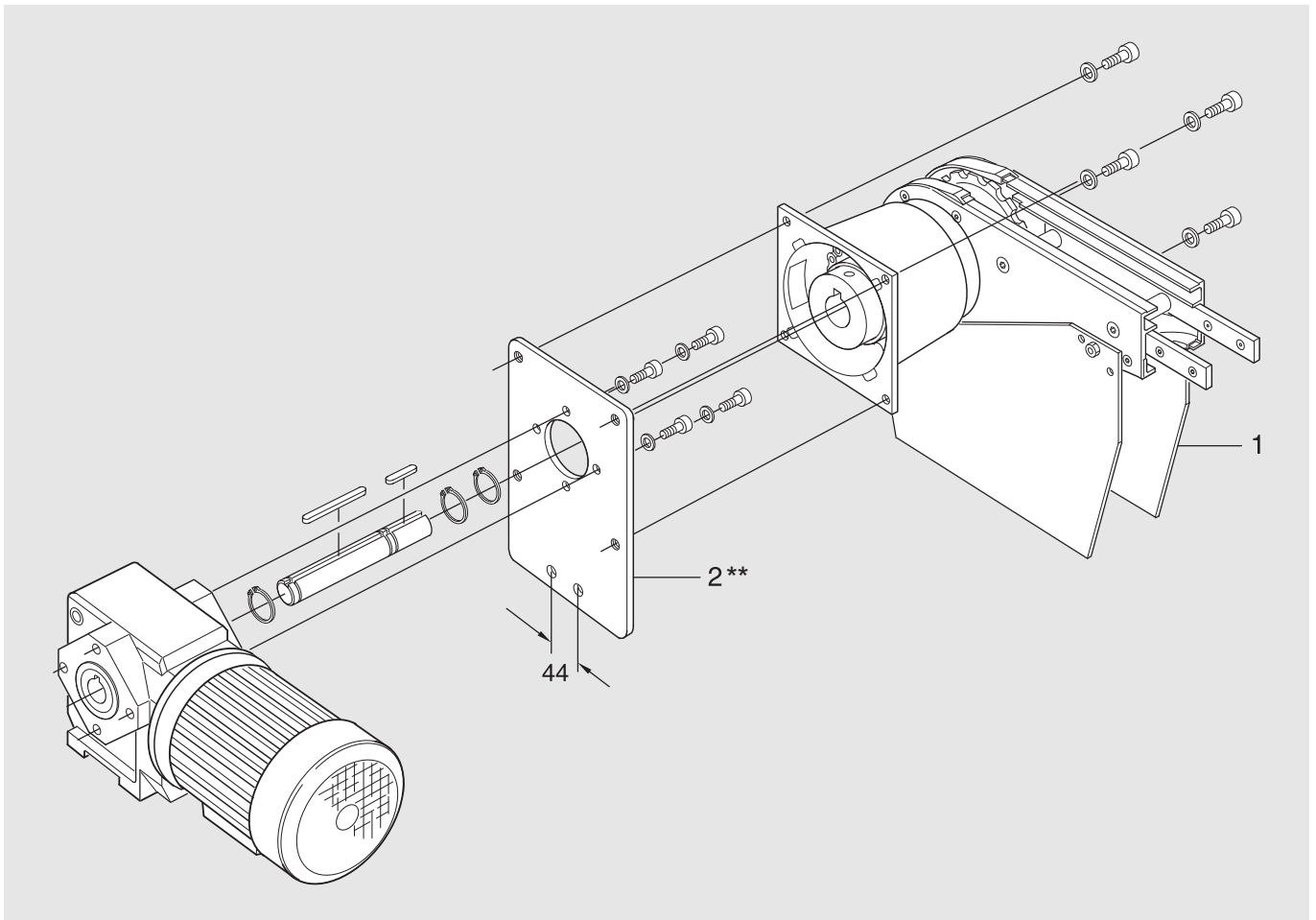

Item	Description	Part No	Qty	Comments	Recommended Spare parts
1	O-unit (left-hand version)	XHEB 0 HLP/HLGP	1	See next page for details	
	O-unit (right-hand version)	XHEB 0 HRP/HRGP	1	See next page for details	
2	Adapter plate including bolts, washers and shaft	5117108	1	**The illustration shows part no 3920088.	

## End drive unit, direct drive / direct drive guided

## 0-unit – XHEB 0 HLP/HRP/HLGP/HRGP

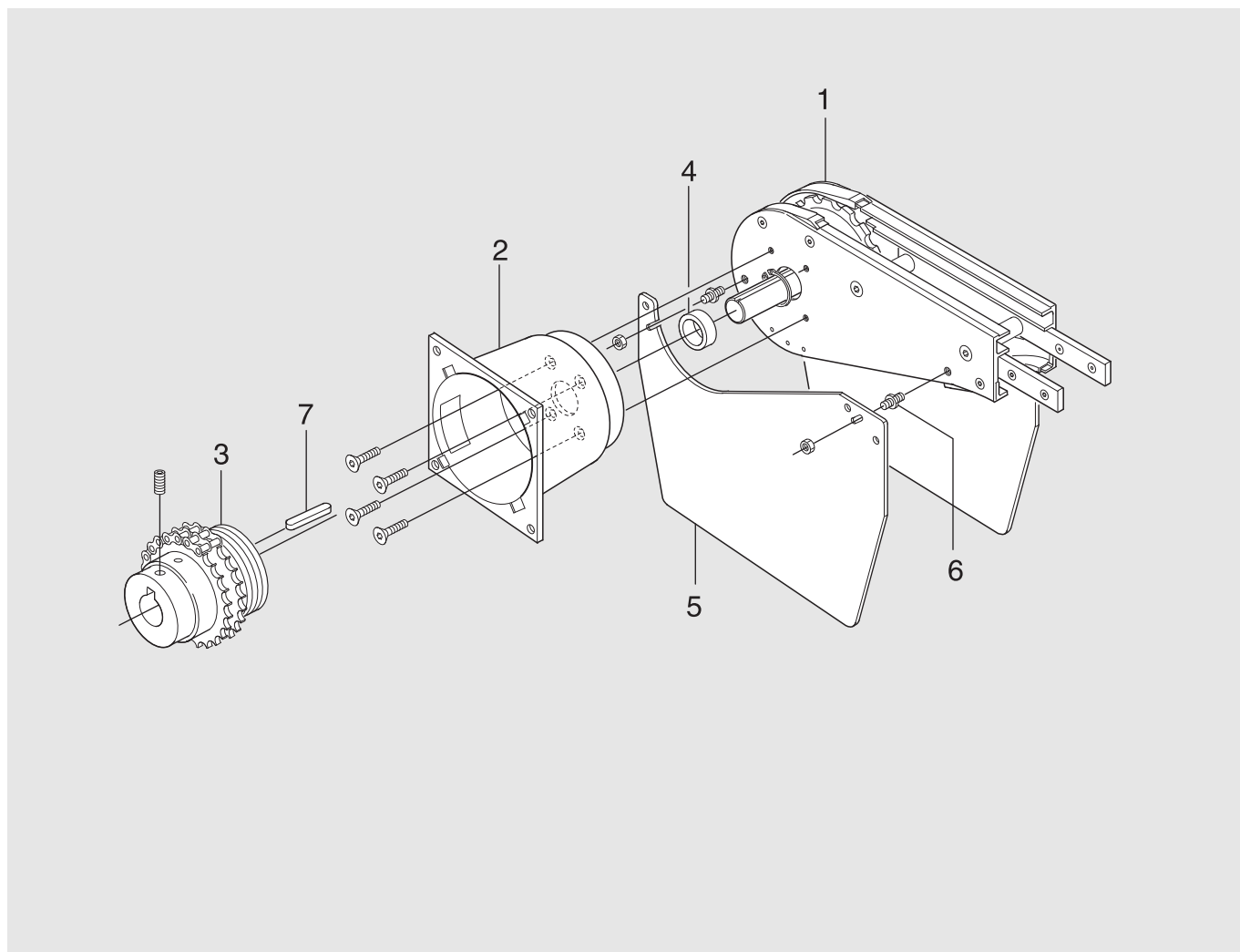

Item	Description	Part No	Qty		Comments	Recommended Spare parts
			HLP/HRP	HLGP/HRGP		
1	Basic unit (left-hand version)	XHEB 0 HLU	1	-	See page 4 for details	
	Basic unit (right-hand version)	XHEB 0 HRU	1	-	See page 4 for details	
	Basic unit (left-hand version)	XHEB 0 HLGU	-	1	See page 13 for details	
	Basic unit (right-hand version)	XHEB 0 HRGU	-	1	See page 13 for details	
2	Flange	3920084		1		
3	Slip clutch Ø20–Ø25 mm	5054003		1		X
4	Distance ring	3921652		1		
5*	Slack protection	(3925673)	2	-	See kit below	
6*	Screw	(3925718)	4	-	See kit below	
7	Thin parallel key	DIN 6885 A h9		1	8x7x40	
*) 5	Slack protection kit	5111581	1	-	LH+RH	
*) 6	Distance screw kit	5111598	1	-	Kit contains 10 pcs	

## End drive unit, overhead motor

Complete unit – XHEH \_HL/HR/HLA/HRA

For SEW S37 gearmotor

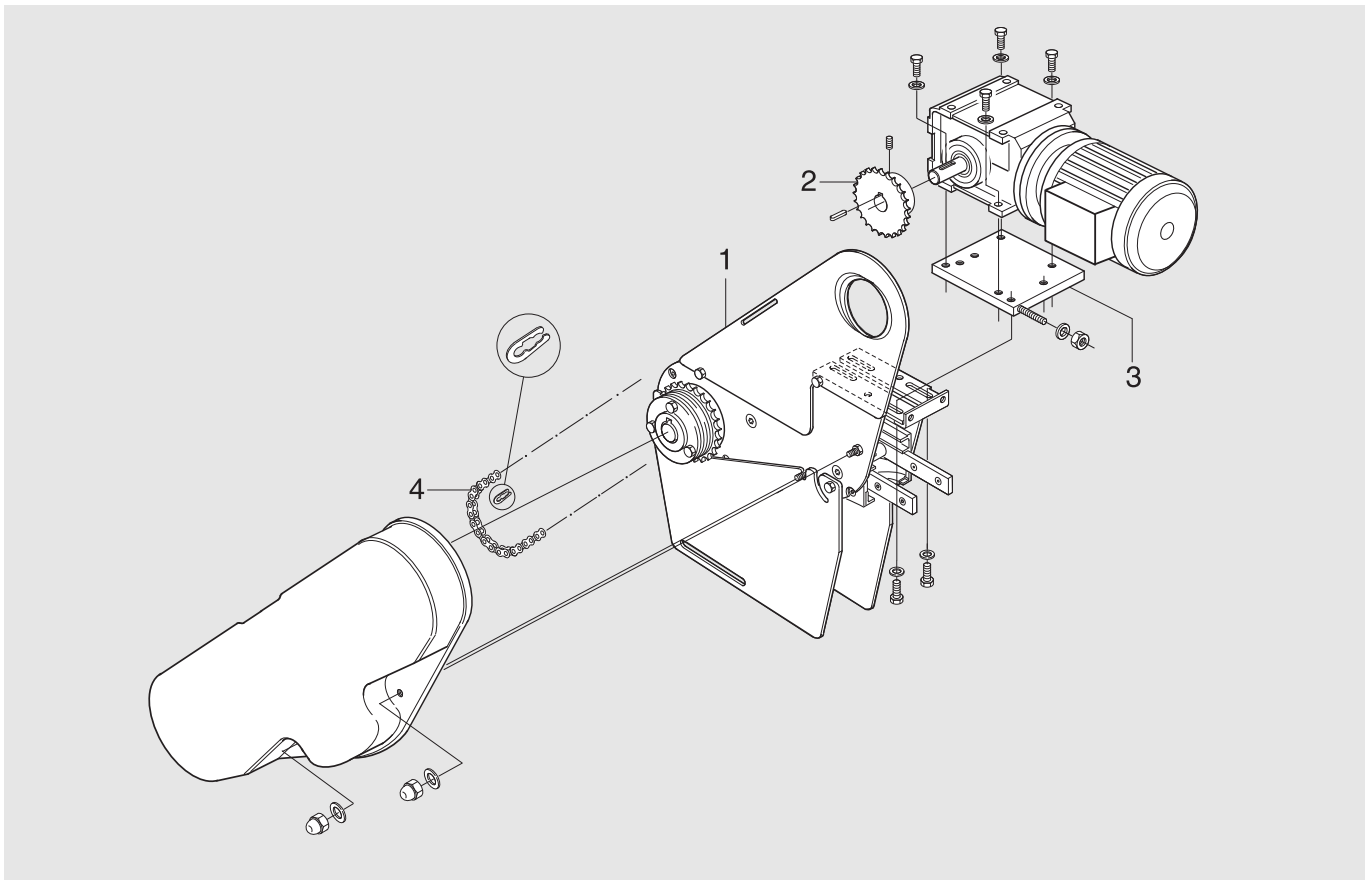

Item	Description	Part No	Qty	Comments	Recommended Spare parts
1	0-unit (left-hand version)	XHEH 0 HL/HLA	1	See next page for details	
	0-unit (right-hand version)	XHEH 0 HR/HRA	1	See next page for details	
2	Sprocket wheel 1/2" including grub screw	See page 2	1		X
3	Adapter plate including bolts and washers	3924197	1	For SEW S37 gearmotor	
	Adapter plate	3924455	1	Blind adapter plate	
4	Transmission chain 1/2" including connecting link	See page 2	1		X
	Transmission chain 1/2" including connecting link	See page 2	1		X

## End drive unit, overhead motor

## O-unit – XHEH 0 HL/HR/HLA/HRA

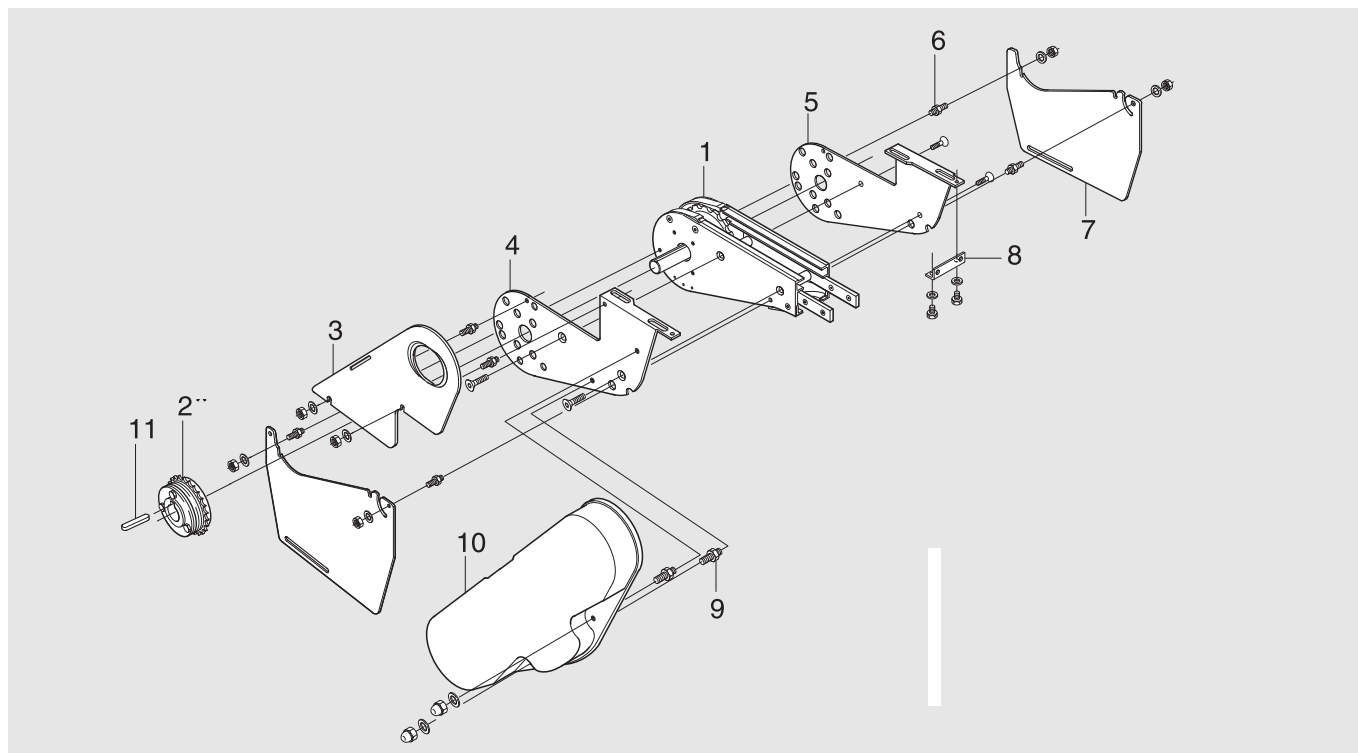

Item	Description	Part No	Qty	Comments	Recommended Spare parts
1	Basic unit (left-hand version)	XHEB 0 HLU	1	See page 4 for details	
	Basic unit (right-hand version)	XHEB 0 HRU	1	See page 4 for details	
2	Slip clutch Ø25 mm	5053981	1	ISO	
	-Slip clutch, Spare parts kit	5056817	1	ISO, incl. cup spring, ball, chain wheel.	X
	Slip clutch Ø25 mm	5054000	1	ANSI	
	-Slip clutch, Spare parts kit	5056820	1	ANSI, incl. cup spring, ball, chain wheel.	X
3	Safety guard	3920751	1		
4	Motor bracket L	3920903	1		
5	Motor bracket R	3920904	1		
6*	Screw	(3904862)	6	See kit below	
7	Slack protection	3926375	2		
8	Adjusting block	3924287	1		
9*	Screw	(3904855)	2	See kit below	
10	Transmission cover	3926374/ 3927191	1	Need to be adjusted: 3926374 Right 3927191 Left	
11	Thin parallel key	DIN 6885A h9	1	8×7×25	
*) 6	Distance screw kit	5111600	1	Kit contains 10 pcs	
*) 9	Distance screw kit	5111599	1	Kit contains 10 pcs	

## End drive unit, guided

Complete unit – XHEB \_HLG/HRG/HLAG/HRAG

For SEW S37 gearmotor

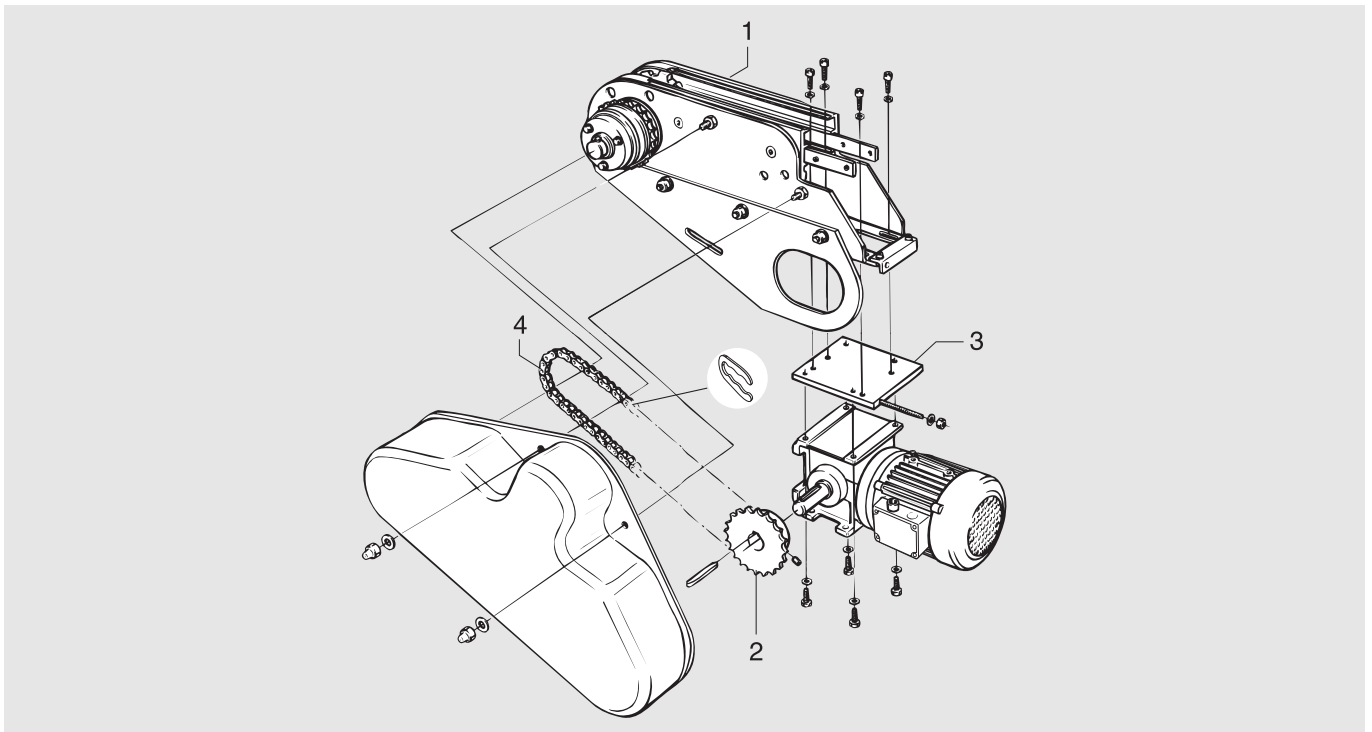

Item	Description	Part No	Qty	Comments	Recommended Spare parts
1	0-unit (left-hand version)	XHEB 0 HLG/HLAG	1	See next page for details	
	0-unit (right-hand version)	XHEB 0 HRG/HRAG	1	See next page for details	
2	Sprocket wheel 1/2" including grub screw	See page 2	1		X
3	Adapter plate including bolts and washers	3924197	1	For SEW S37 gearmotor	
	Adapter plate	3924455	1	Blind adapter plate	
4	Transmission chain 1/2" including connecting link	See page 2	1		X
	Transmission chain 1/2" including connecting link	See page 2	1		X

## End drive unit, guided

## 0-unit – XHEB 0 HLG/HRG/HLAG/HRAG

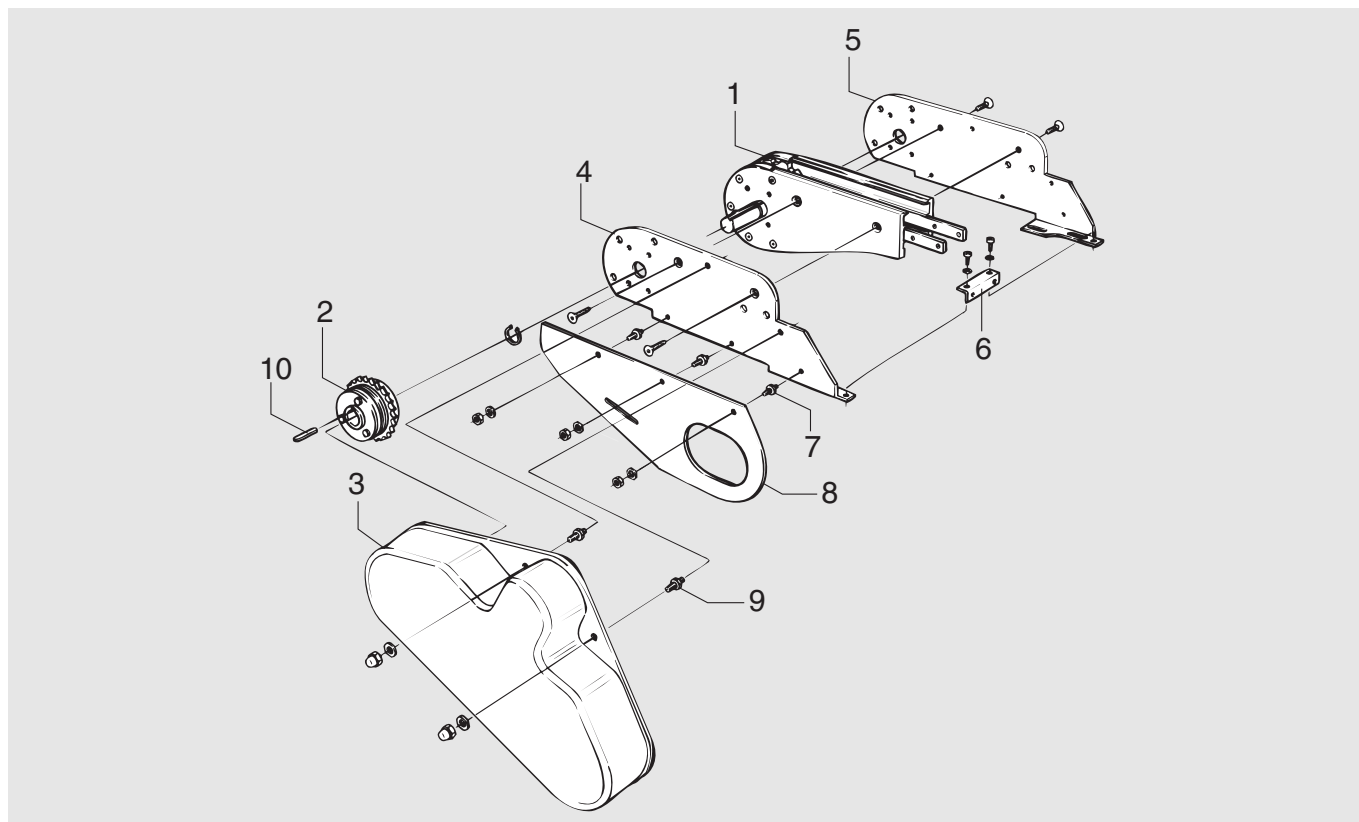

Item	Description	Part No	Qty	Comments	Recommended Spare parts
1	Basic unit (left-hand version)	XHEB 0 HLGU	1	See next page for details	
	Basic unit (right-hand version)	XHEB 0 HRGU	1	See next page for details	
2	Slip clutch Ø25 mm	5053981	1	ISO	
	-Slip clutch, Spare parts kit	5056817	1	ISO, incl. cup spring, ball, chain wheel.	X
	Slip clutch Ø25 mm	5054000	1	ANSI	
	-Slip clutch, Spare parts kit	5056820	1	ANSI, incl. cup spring, ball, chain wheel.	X
3	Transmission cover	3904431	1		
4	Motor bracket L	3904527	1		
5	Motor bracket R	3904528	1		
6	Adjusting block	3924287	1		
7*	Distance screw	(3904862)	3	See kit below	
8*	Slack protection	(3925875)	1	See kit below	
9*	Distance screw	(3904855)	2	See kit below	
10	Thin parallel key	DIN 6885A h9	1	8×7×25	
*7)	Distance screw kit	5111600	1	Kit contains 10 pcs	
*8)	Slack protection kit	5111608	1	LH+RH	
*9)	Distance screw kit	5111599	1	Kit contains 10 pcs	

## End drive unit, guided

## Basic unit – XHEB 0 HLGU/HRGU

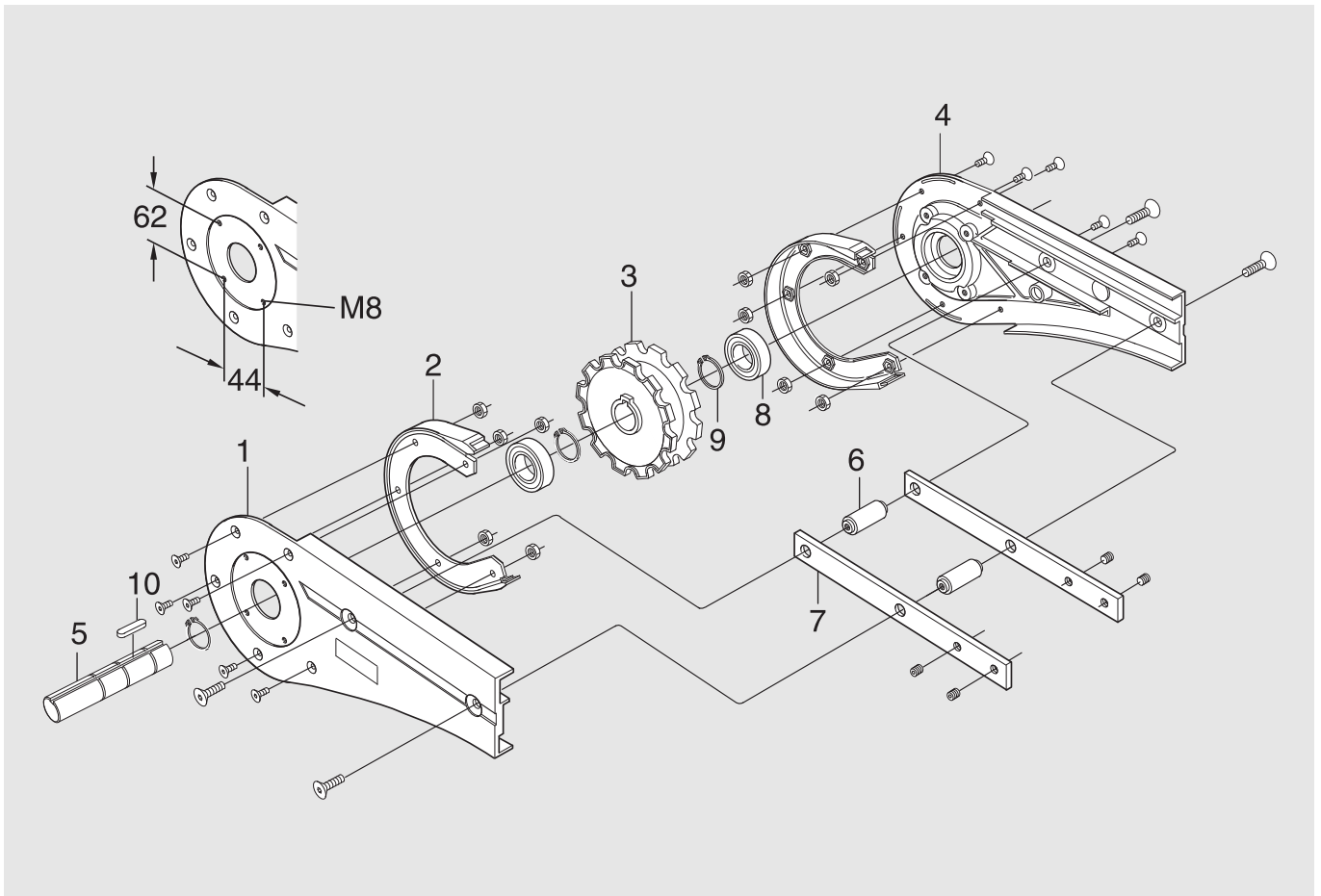

Item	Description	Part No	Qty	Comments	Recommended Spare parts
1*	Side plate L	(5130477)	1	See kit below	
2*	Steering guide	(3921164)	2	See kit below	
3*	Drive wheel	5111627	1	(3904299)	X
4*	Side plate R	(5130476)	1	See kit below	
5*	Drive shaft	(3904403)	1	See kit below	
6	Distance	3904140	2		
7	Connecting strip	3921123	2		
8*	Bearing	(6205 2RS1/C3)	2		
9*	Retaining ring	DIN 471	3	25 st	
10*	Thin parallel key	DIN 6885A h9	1	8x7x63	
*) 1+4	Side plate kit	5111634	1	LH+RH	
*) 2	Spare parts kit Steering guide	5111626	1	LH+RH	X
*) 3+5+8+9+10	Wheel kit	5111632	1		X



## Double drive unit- XH

### Revision list

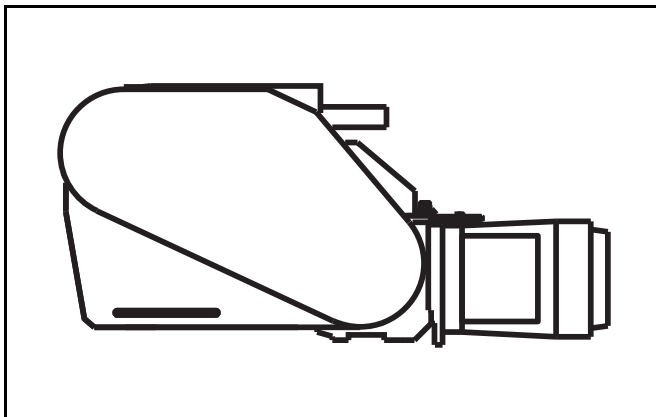

Document designation	Date	Type of revision	Entered by
XH002-E1	98-10-14	New version	Enator Inforum
XH002-E2	99-09-13	Double drive unit (c/c106 mm)	TietoEnator
XH002-E3	08-10-23	Spare part kits added	JE
XH002-E4	09-03-19		JE
XH002-E5	10-07-07	Added new column	CB
XH002-E6	19-12-19	Updated sprocket wheel tables	ML
XH002-07	21-05-03	Updated logo and lists	TG
XH002-08	22-01-19	Side plate no updated	TG

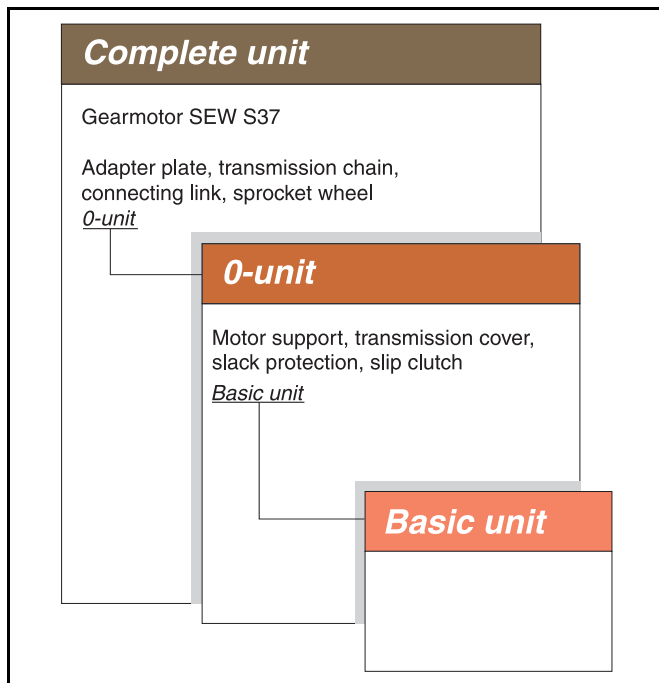

## Double drive unit (c/c 106 mm)

Complete unit – XHEB \_HLD/HRD/HLAD/HRAD106\*

For SEW S37 gearmotor

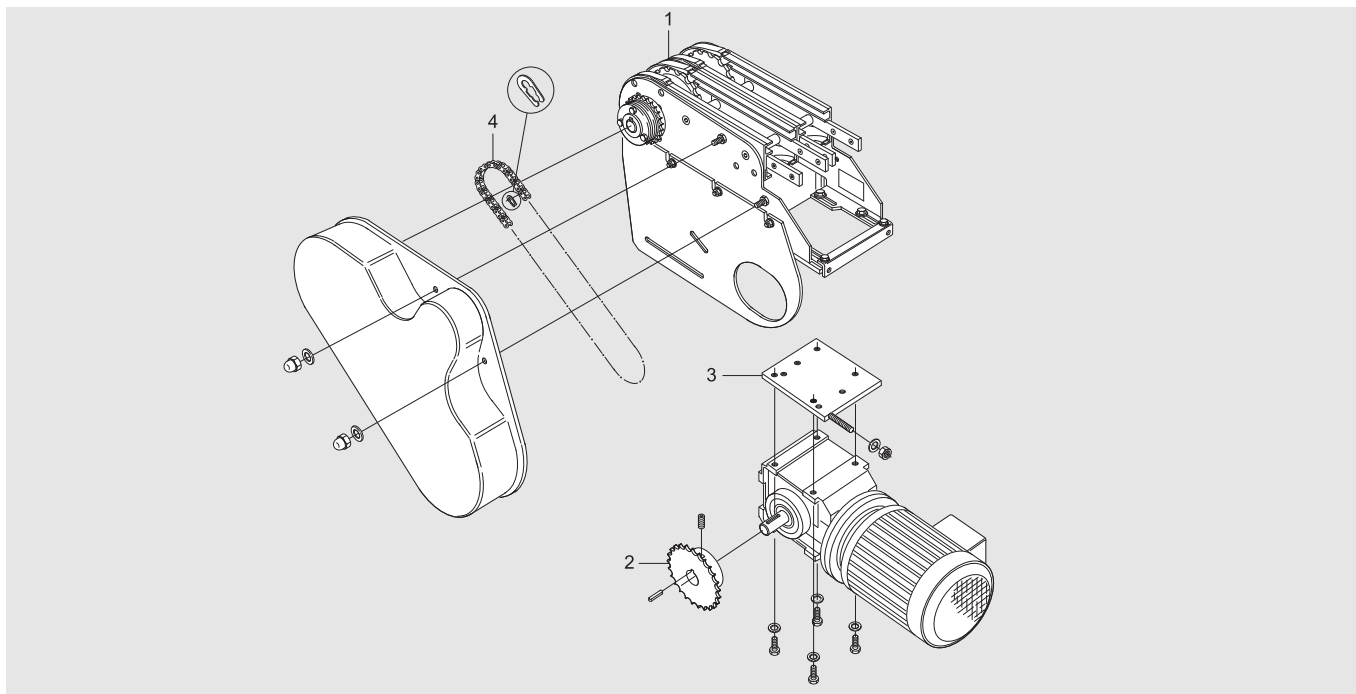

Item	Description	Part No	Qty	Comments	Recommended Spare parts
1	0-unit (left-hand version)	XHEB 0 HLD/HLAD106	1	See next page for details	
	0-unit (right-hand version)	XHEB 0 HRD/HRAD106	1	See next page for details	
2	Sprocket wheel 1/2" including grub screw		1	See table below	X
3	Adapter plate including bolts and washers	3924197	1	For SEW S37 gearmotor	
4	Transmission chain 1/2" including connecting link	3921638	1	ISO/R- 1967- 08B- 1 (ISO)	X
	Transmission chain 1/2" including connecting link	5044948	1	ISO/R- 1967- 08A- 1 (ANSI)	X

\* c/c 106 mm

Important  
Items 2-4 must be ordered separately when ordering a 0-unit (item 1). The sprocket wheel (item 2) should be specified in accordance with the following table:

Sprocket wheel 1/2"	Part No (SEW)	Shaft diameter
z=19 ISO	3924438	20
z=21 ISO	3924439	20
z=23 ISO	3924440	20
z=25 ISO	3921258	20
z=15 ANSI	5044935	19,05
z=17 ANSI	5044936	19,05
z=19 ANSI	5044937	19,05
z=21 ANSI	5044938	19,05
z=23 ANSI	5044939	19,05
z=25 ANSI	5044940	19,05

## Double drive unit (c/c 106 mm)

0-unit – XHEB 0 HLD/HRD/HLAD/HRAD106\*\*

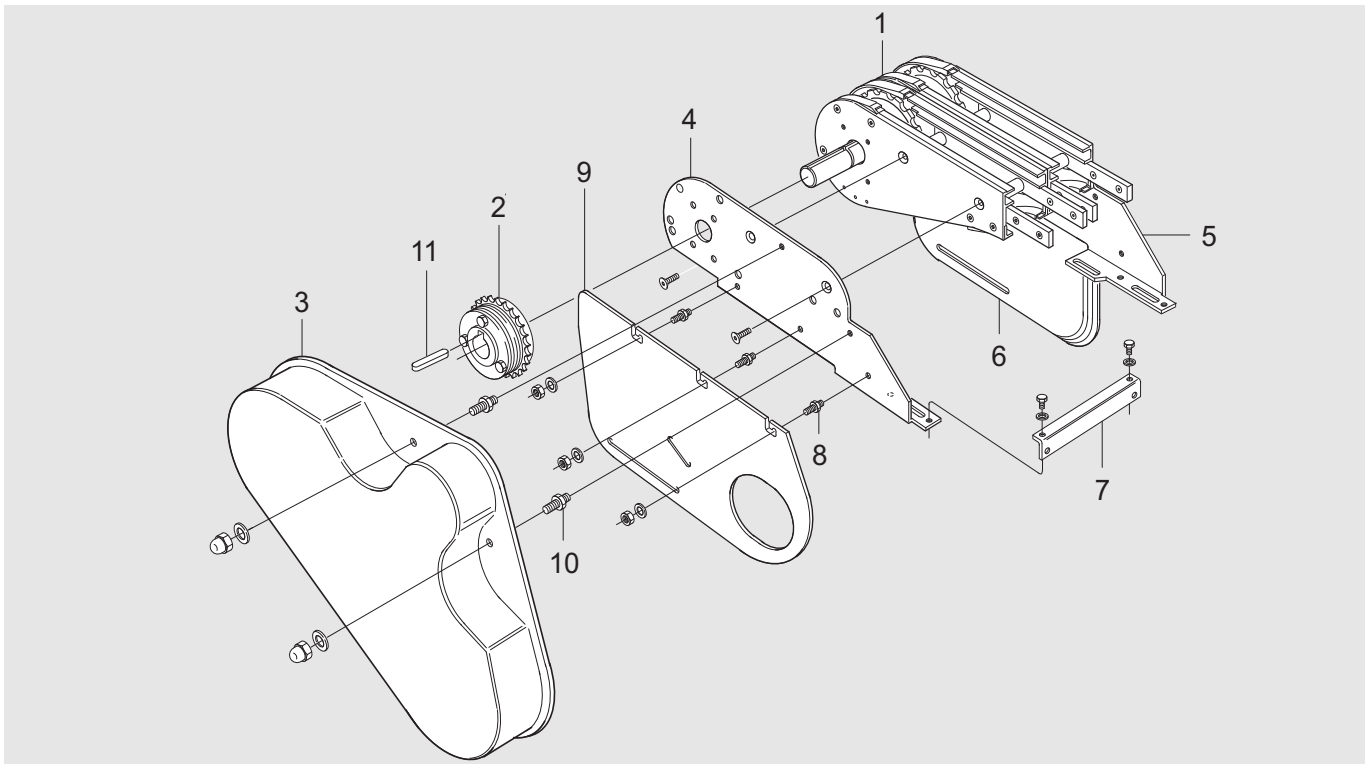

Item	Description	Part No	Qty	Comments	Recommended Spare parts
1	Basic unit	XHEB 0 HLDU106	1	See next page for details	
	Basic unit	XHEB 0 HRDU106	1	See next page for details	
2	Slip clutch Ø25 mm	5053981	1	ISO	
	-Slip clutch, Spare parts kit	5056817	1	ISO, incl. cup spring, ball, chain wheel	X
	Slip clutch Ø25 mm	5054000	1	ANSI	
	-Slip clutch, Spare parts kit	5056820	1	ANSI, incl. cup spring, ball, chain wheel	X
3	Transmission cover	3904431	1		
4	Motor bracket	3904527	1		
5	Motor bracket	3904528	1		
6*	Slack protection R	(3904665)	1	See kit below	
7	Adjusting block	3926279	1		
8*	Distance screw M6	(3904862)	5	See kit below	
9*	Slack protection L	(3904666)	1	See kit below	
10*	Distance screw M8	(3904855)	2	See kit below	
11	Adapter plate	3926310	1	c/c 106	
12	Thin parallel key	DIN 6885A h9	1	8×7×25	
*) 6+9	Slack protection kit	5111566	1	LH+RH	
*) 8	Distance screw kit	5111600	1	Kit contains 10 pcs	
*) 10	Distance screw kit	5111599	1	Kit contains 10 pcs	

\* \*c/c 106 mm

## Double drive unit

## Basic unit – Parts list

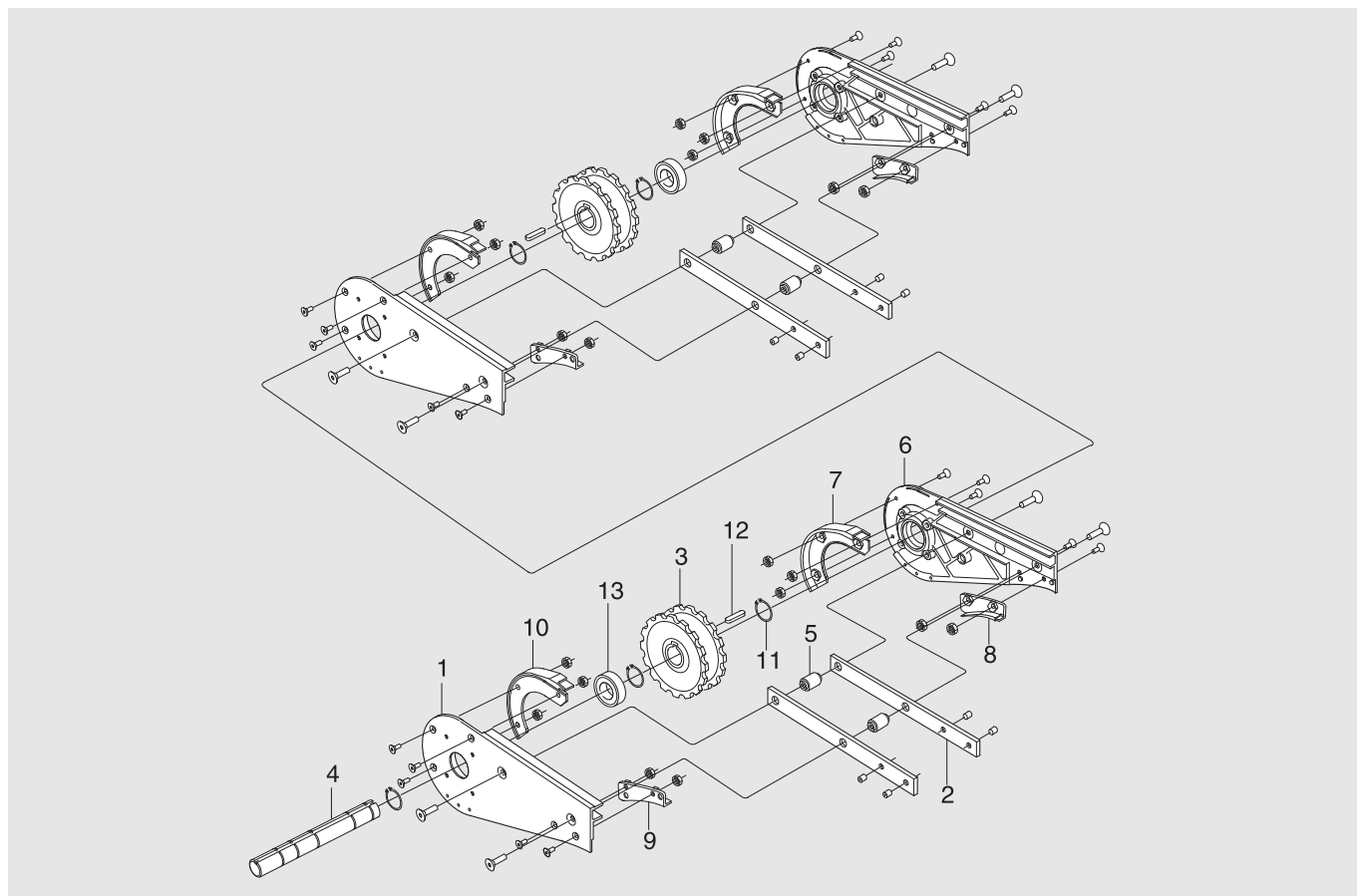

Item	Description	Part No	Qty	Comments	Recommended Spare parts
1*	Side plate L	(5130578)	2	See kit below	
2	Connecting strip	3904139	4		
3	Drive wheel	5111627	2	(3904299)	X
4	Drive shaft	3926311	1	c/c 106	
		3926277	1	c/c 150–350	
5	Spacer	3904140	4		
6*	Side plate R	(5130506)	2	See kit below	
7*	Steering guide	(3904312)	2	See kit below	
8*	Guide R	(3904313)	2	See kit below	
9*	Guide L	(3904744)	2	See kit below	
10*	Steering guide L	(3904745)	2	See kit below	
11	Retaining ring	DIN 471	5	25 st	
12	Thin parallel key	DIN 6885A h9	2	8×7×63	
13	Bearing	6205 2RS1/C3	2		
*) 1+6	Side plate kit	5111628	1	LH+RH	
*) 7+10	Spare parts kit Steering guide	5111629	1	LH+RH	X
*) 8+9	Spare parts kit Guide kit	5111622	1	LH+RH	X

## Double drive unit (c/c 150-350 mm)

Complete unit – XHEB\_HLD/HRD/HLAD/HRAD-\*

For SEW S37 gearmotor

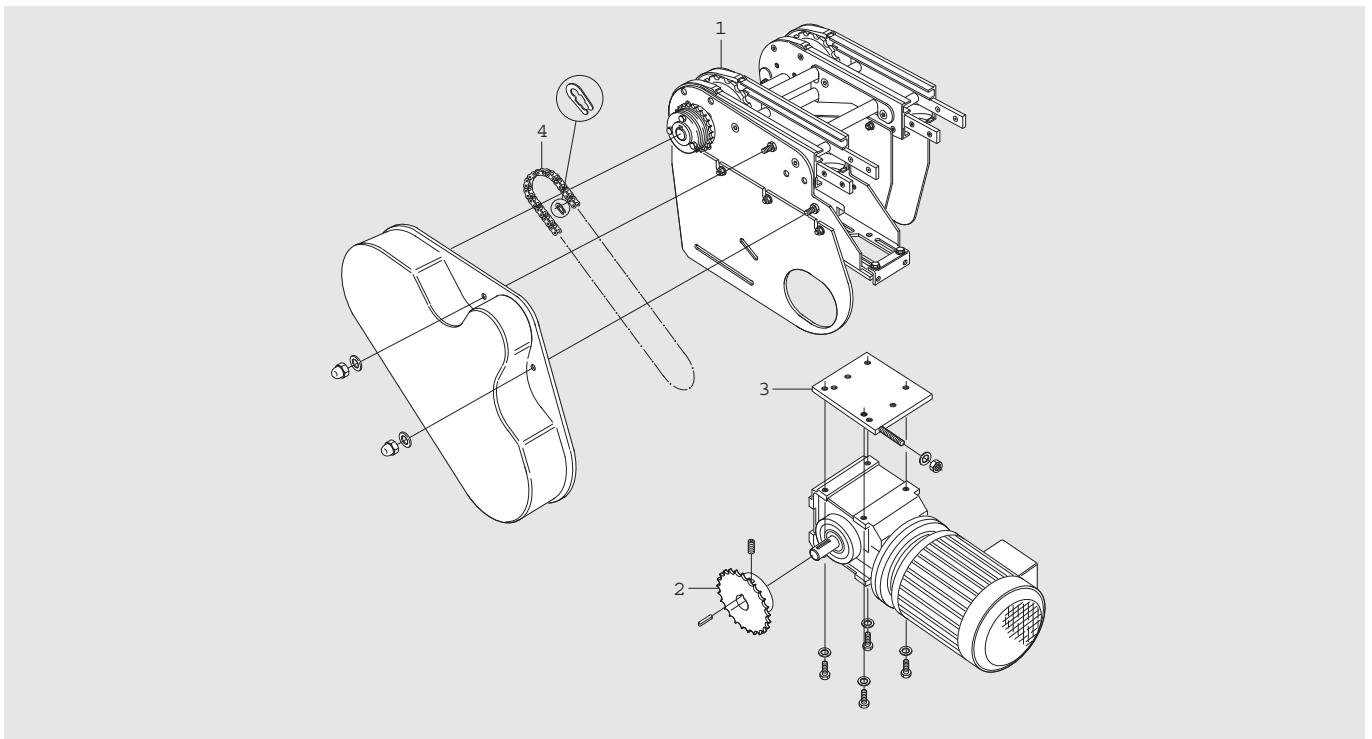

Item	Description	Part No	Qty	Comments	Recommended Spare parts
1	0-unit (left-hand version)	XHEB 0 HLD/HLAD-	1	See next page for details	
	0-unit (right-hand version)	XHEB 0 HRD/HRAD-	1	See next page for details	
2	Sprocket wheel 1/2" including grub screw		1	See table below	X
3	Adapter plate including bolts and washers	3924197	1	For SEW S37 gearmotor	
4	Transmission chain 1/2" including connecting link	3921638	1	ISO/R- 1967- 08B- 1 (ISO)	X
	Transmission chain 1/2" including connecting link	5044948	1	ISO/R- 1967- 08A- 1 (ANSI)	X

\* The dash (-) indicates a customer specified c/c distance in the range 150 mm to 350 mm.

Important

Items 2-4 must be ordered separately when ordering a 0-unit (item 1).

The sprocket wheel (item 2) should be specified in accordance with the following table:

Sprocket wheel 1/2"	Part No (SEW)	Shaft diameter
z=19 ISO	3924438	20
z=21 ISO	3924439	20
z=23 ISO	3924440	20
z=25 ISO	3921258	20
z=15 ANSI	5044935	19,05
z=17 ANSI	5044936	19,05
z=19 ANSI	5044937	19,05
z=21 ANSI	5044938	19,05
z=23 ANSI	5044939	19,05
z=25 ANSI	5044940	19,05

## Double drive unit (c/c 150-350 mm)

0-unit – XHEB 0 HLD/HRD/HLAD/HRAD-\*

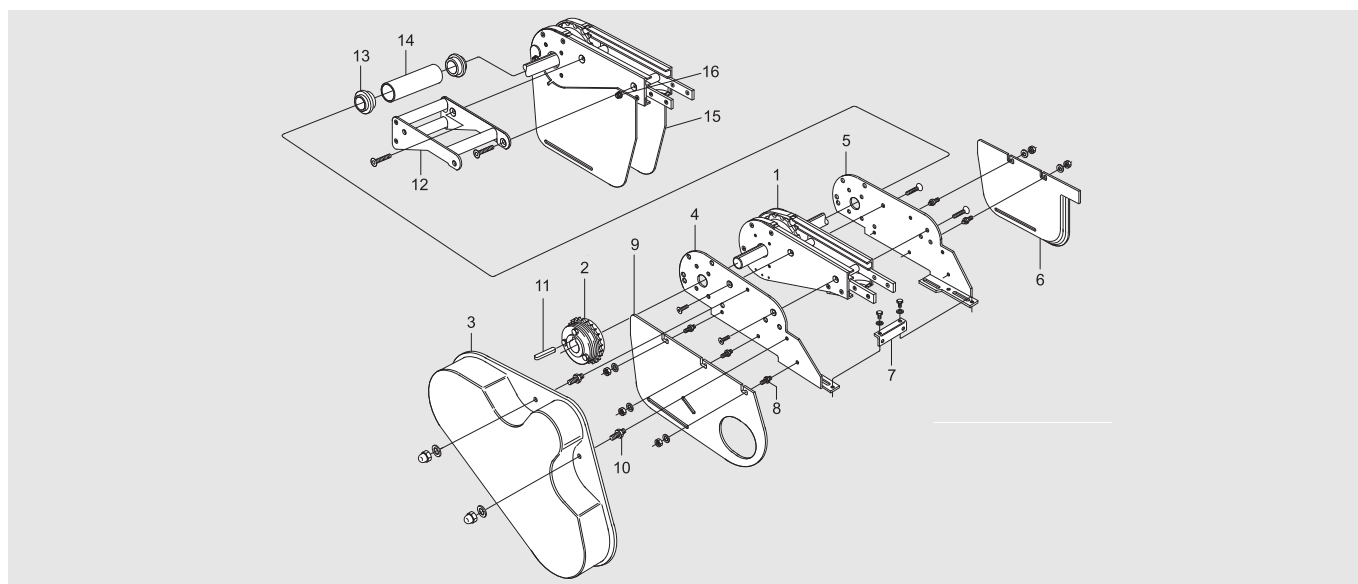

Item	Description	Part No	Qty	Comments	Recommended Spare parts
1	Basic unit	XHEB 0 HLDU-	1	See page 4 for details	
	Basic unit	XHEB 0 HRDU-	1	See page 4 for details	
2	Slip clutch Ø25 mm	5053981	1	ISO	
	-Slip clutch, Spare parts kit	5056817	1	ISO, incl. cup spring, ball, chain wheel	X
	Slip clutch Ø25 mm	5054000	1	ANSI	
	-Slip clutch, Spare parts kit	5056820	1	ANSI, incl. cup spring, ball, chain wheel	X
3	Transmission cover	3904431	1		
4	Motor bracket	3904527	1		
5	Motor bracket	3904528	1		
6*	Slack protection	(3904665)	1	See kit below	
7	Adjusting block	3925469	1		
8*	Distance screw M6	(3904862)	9	See kit below	
9*	Slack protection	(3904666)	1	See kit below	
10*	Distance screw M8	(3904855)	2	See kit below	
11	Thin parallel key	DIN 6885A h9	1	8×7×25	
12	Fastener yoke	5046915	1		
13	Bushing	5044695	2		
14	Sleeve	5046917	1		
15*	Slack protection	(3925673)	2	See kit below	
16	Distance screw	3925718	2		
*) 6+9	Slack protection kit	5111566	1	LH+RH	
*) 8	Distance screw kit	5111600	1	Kit contains 10 pcs	
*) 10	Distance screw kit	5111599	1	Kit contains 10 pcs	
*) 15	Slack protection kit	5111581	1		

\* The dash (-) indicates a customer specified c/c distance in the range 150 mm to 350 mm.

# Spare parts Intermediate drive unit -XH

Technical information from FlexLink

XH003-E7

## Intermediate drive unit- XH

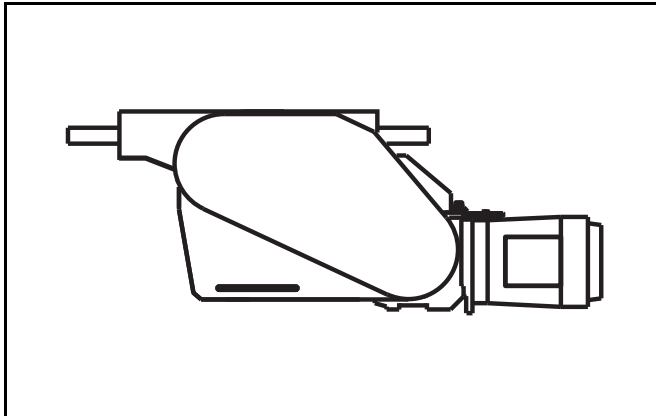

### Revision list

Document designation	Date	Type of revision	Entered by
XH003-E1	98-10-14	New version	Enator Inforum
XH003-E2	08-10-23	Spare part kits added	JE
XH003-E3	09-03-19		JE
XH003-E4	09-10-22	Ch. part no.	JE
XH003-E5	10-07-06	Added new column	CB
XH003-E6	19-12-09	Updated sprocket wheel table	ML
XH004-E7	21-05-03	Updated logo and lists	TG

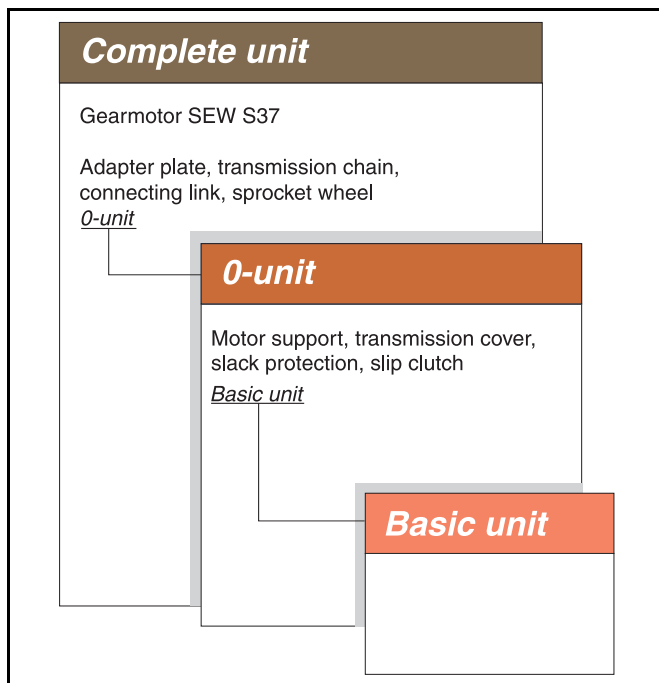

## Intermediate drive unit

Complete unit – XHER \_HL/HR/HLA/HRA

For SEW S37 gearmotor

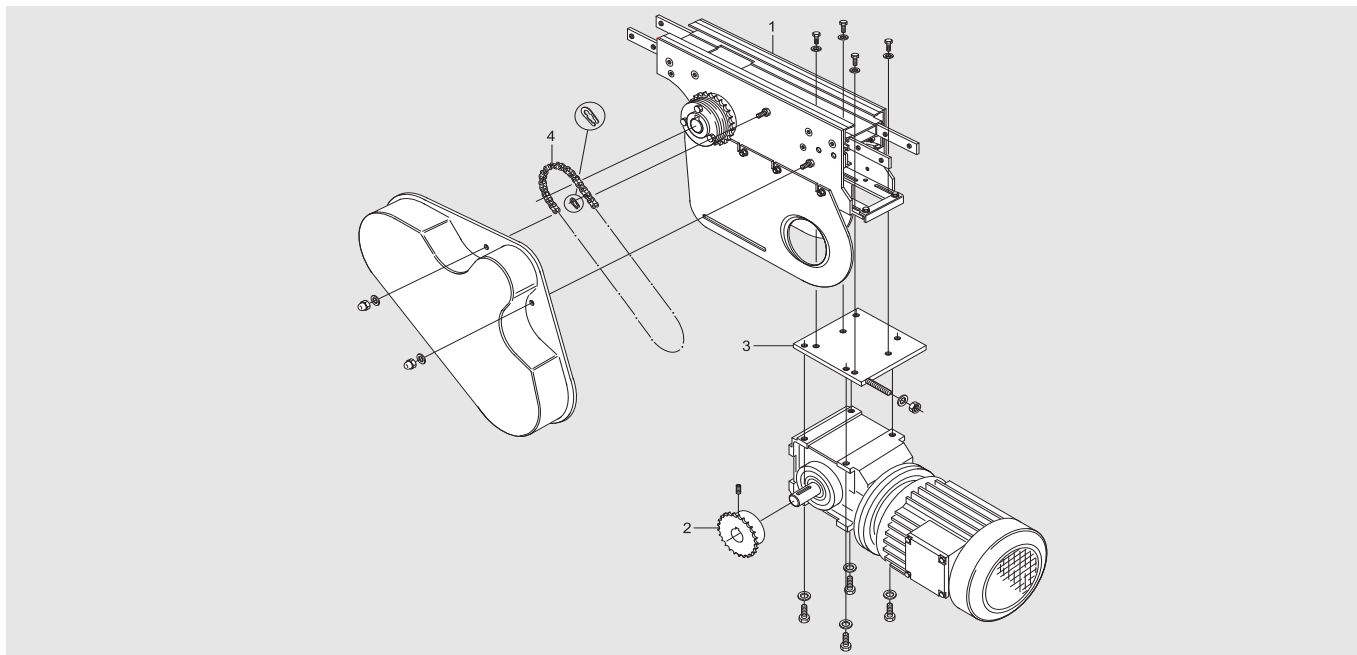

Item	Description	Part No	Qty	Comments	Recommended Spare parts
1	0-unit (left-hand version)	XHER 0 HL/HLA	1	See next page for details	
	0-unit (right-hand version)	XHER 0 HR/HRA	1	See next page for details	
2	Sprocket wheel 1/2" including grub screw		1	See table below	X
3	Adapter plate including bolts and washers	3924197	1	For SEW S37 gearmotor	
4	Transmission chain 1/2" including connecting link	3921638	1	ISO/R- 1967- 08B- 1 (ISO)	X
	Transmission chain 1/2" including connecting link	5044948	1	ISO/R- 1967- 08A- 1 (ANSI)	X

## Important

Items 2-4 must be ordered separately when ordering a 0-unit (item 1). The sprocket wheel (item 2) should be specified in accordance with the following table:

Sprocket wheel 1/2"	Part No (SEW)	Shaft diameter
z=19 ISO	3924438	20
z=21 ISO	3924439	20
z=23 ISO	3924440	20
z=25 ISO	3921258	20
z=15 ANSI	5044935	19,05
z=17 ANSI	5044936	19,05
z=19 ANSI	5044937	19,05
z=21 ANSI	5044938	19,05
z=23 ANSI	5044939	19,05
z=25 ANSI	5044940	19,05

## Intermediate drive unit

## 0-unit – XHER 0 HL/HR/HLA/HRA

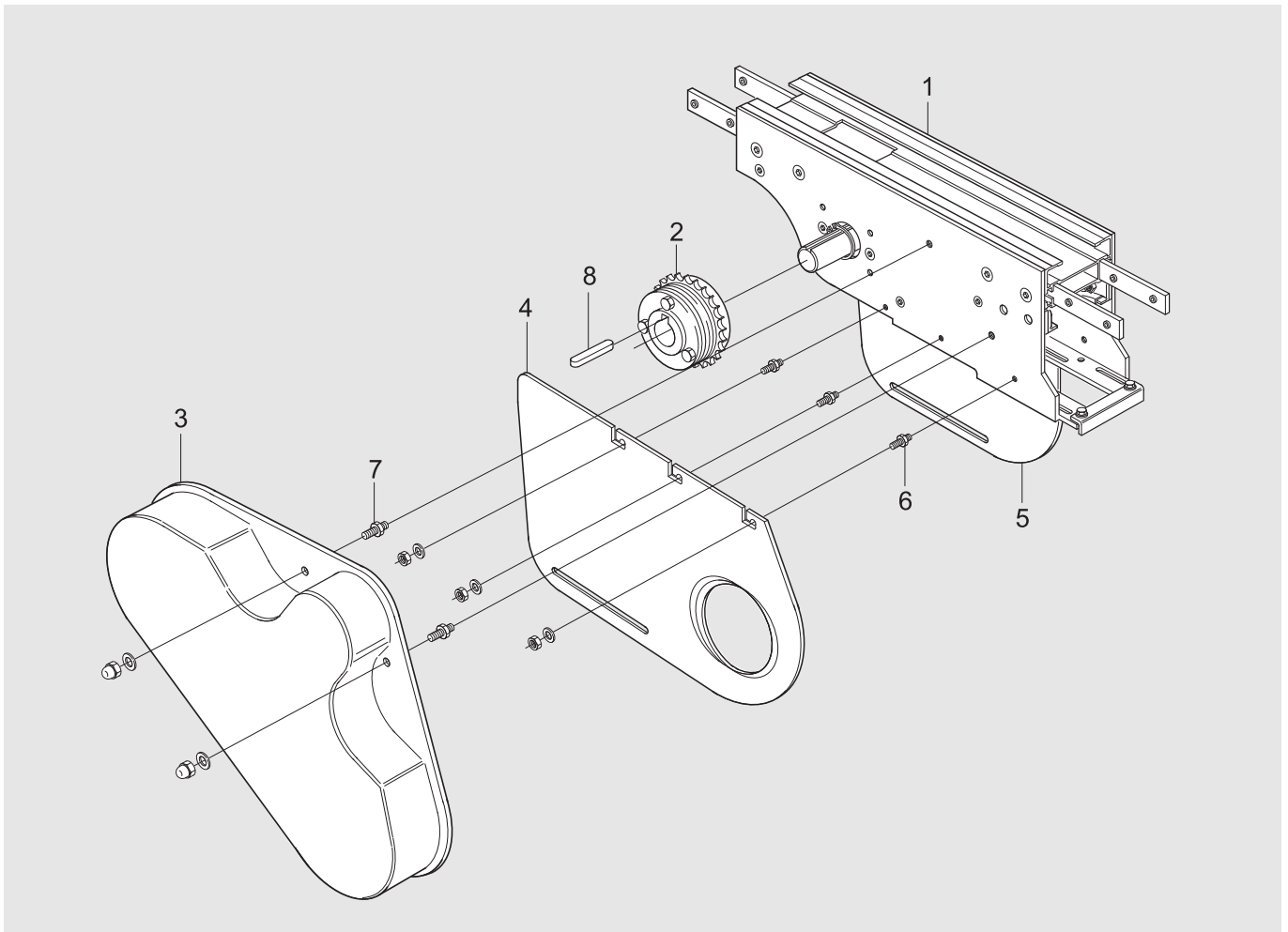

Item	Description	Part No	Qty	Comments	Recommended Spare parts
1	Basic unit (left-hand version)	XHER 0 HLU	1	See next page for details	
	Basic unit (right-hand version)	XHER 0 HRU	1	See next page for details	
2	Slip clutch Ø25 mm	5053981	1	ISO	
	-Slip clutch, Spare parts kit	5056817	1	ISO, incl. cup spring, ball, chain wheel	X
	Slip clutch Ø25 mm	5054000	1	ANSI	
	-Slip clutch, Spare parts kit	5056820	1	ANSI, incl. cup spring, ball, chain wheel	X
3	Transmission cover	3904431	1		
4*	Slack protection L	(3904666)	1	See kit below	
5*	Slack protection	(3904665)	1	See kit below	
6*	Screw	(3904862)	5	See kit below	
7*	Screw	(3904855)	2	See kit below	
8	Thin parallel key	DIN 6885A h9	1	8×7×25	
*)	Slack protection kit	5111566	1	LH+RH	
4+5					
*) 6	Distance screw kit	5111600	1	Kit contains 10 pcs	
*) 7	Distance screw kit	5111599	1	Kit contains 10 pcs	

## Intermediate drive unit

## Basic unit – XHER 0 HLU/HRU

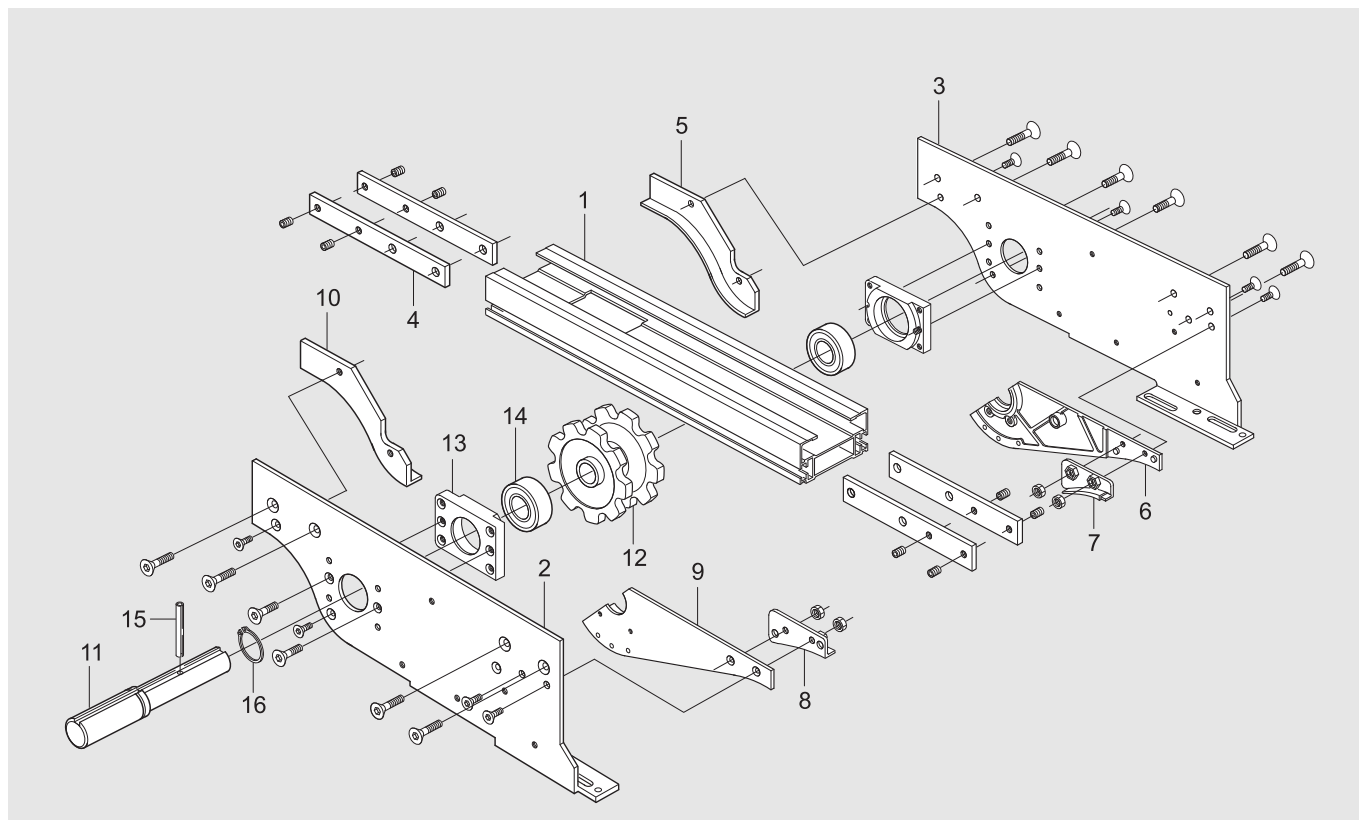

Item	Description	Part No	Qty	Comments	Recommended Spare parts
1	Beam	3926790	1		
2	Side plate LH	3927121	1		
3	Side plate RH	3927122	1		
4	Connecting strip	3924975	4		
5*	Steering guide RH	(3902661)	1	See kit below	
6	Side plate RH	3927180	1		
7*	Guide RH	(3904313)	1	See kit below	
8*	Guide LH	(3904744)	1	See kit below	
9	Side plate LH	3927181	1		
10*	Steering guide LH	(3924634)	1	See kit below	
11	Drive shaft	3926791	1		
12*	Drive wheel	(3902527)	1	See kit below	
13	Bearing house	3927119	2		
14	Bearing	6204-RS1/C3	2		
15	Tension pin	ISO 8752	1	6x 55	
16	Retaining ring	DIN 471	1	25 st	
*) 5+10	Spare parts kit Steering guide	5111621	1	LH+RH	X
*) 7+8	Spare parts kit Guide	5111622	1	LH+RH	X
*) 12	Wheel	5111623	1	(3902527)	X

# Catenary drive unit- XH

## Revision list

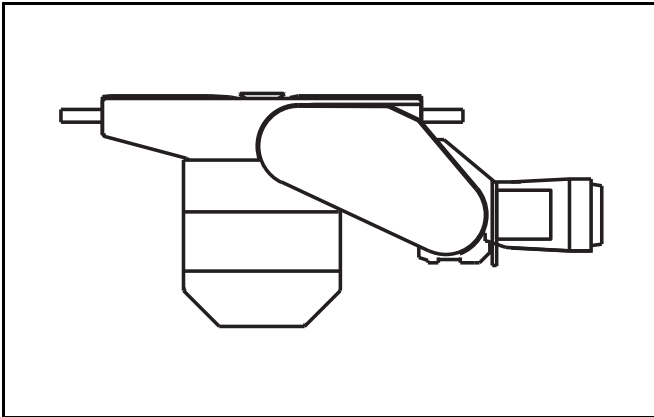

Document designation	Date	Type of revision	Entered by
XH004-E1	98-10-14	New version	Enator Inforum
XH004-E2	10-08-20	Added new col.	JE
XH004-E3	19-12-09	Updated sprocket wheel table	ML
XH004-E4	21-05-03	Updated logo and lists	TG
XH004-E5	22-01-19	Updated side plate no.	TG
XH004-E6	23-03-23	added steering guide kit p. 28, 29	TG
XH004-E7	25-08-26	Catenary drive unit, 0-unit – XHEC 0 HL/HR/HLA/HRA: Updated Chain guard, Cover, Thin parallel key info. Basic unit–XHEB 0 HLU/HRU: Refer to Basic unit–XHEB 0 HLU/HRU in XH001-E8 Idler unit–3921481: Updated image and list.	IR

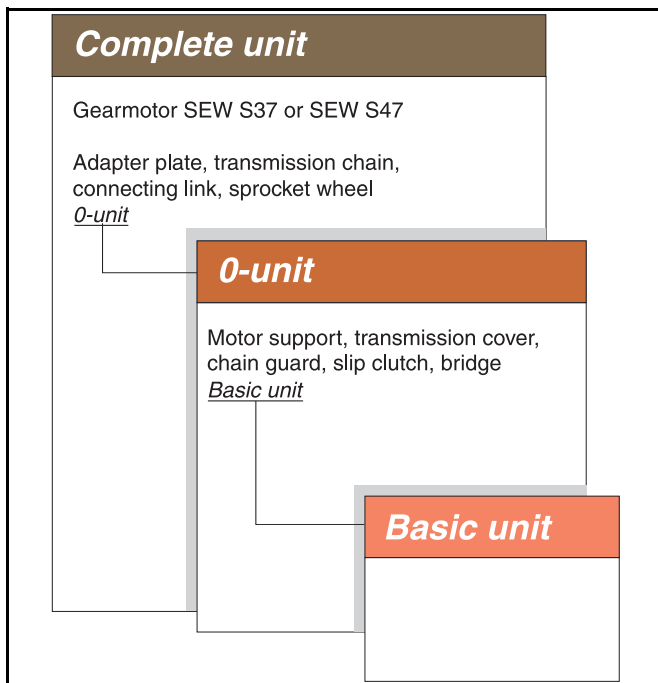

## Catenary drive unit

### Complete unit – XHEC\_HL/HR/HLA/HRA

For SEW S37 gearmotor

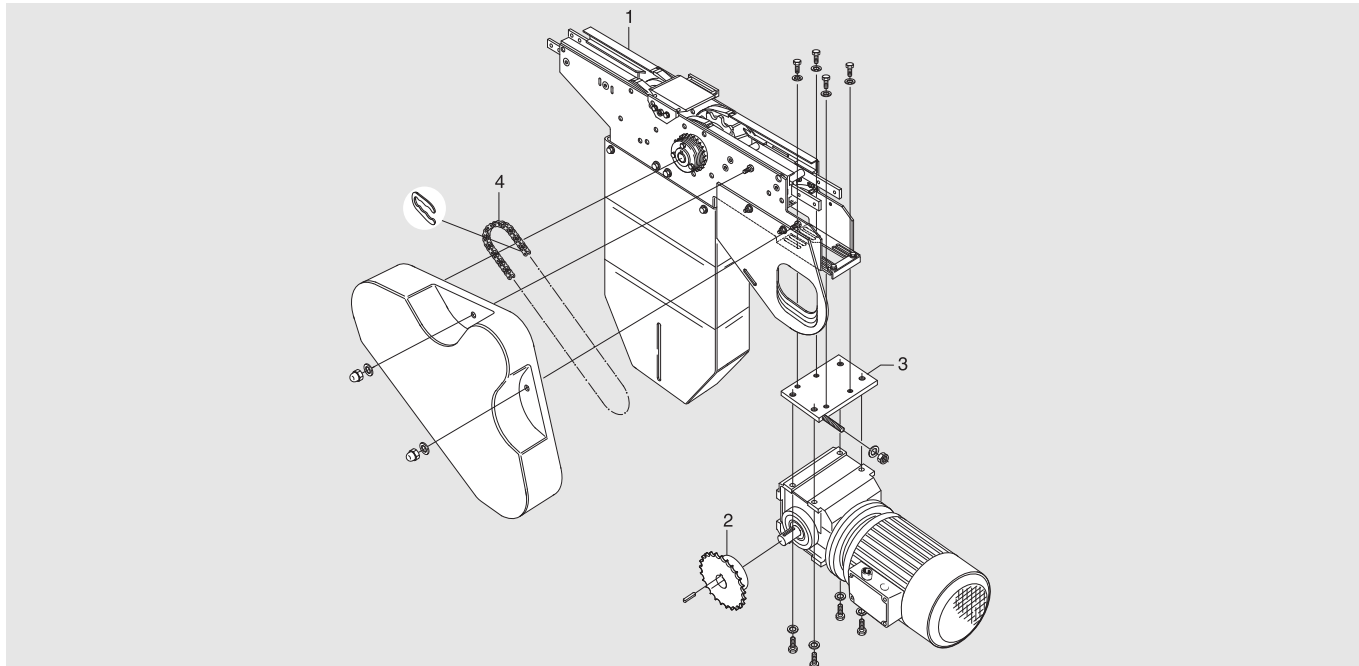

Item	Description	Part No	Qty	Comments	Recommended Spare parts
1	0-unit (left-hand version)	XHEC 0 HL/HLA	1	See next page for details	
	0-unit (right-hand version)	XHEC 0 HR/HRA	1	See next page for details	
2	Sprocket wheel 1/2" including grub screw		1	See table below	X
3	Adapter plate including bolts and washers	3924197	1	For SEW S37 gearmotor	
4	Transmission chain 1/2" including connecting link	3921638	1	ISO/R- 1967- 08B- 1 (ISO)	X
	Transmission chain 1/2" including connecting link	5044948	1	ISO/R- 1967- 08A- 1 (ANSI)	X

#### Important

Items 2-4 must be ordered separately when ordering a 0-unit (item 1). The sprocket wheel (item 2) should be specified in accordance with the following table:

Sprocket wheel 1/2"	Part No (SEW)	Shaft diameter
z=19 ISO	3924438	20
z=21 ISO	3924439	20
z=23 ISO	3924440	20
z=25 ISO	3921258	20
z=15 ANSI	5044935	19,05
z=17 ANSI	5044936	19,05
z=19 ANSI	5044937	19,05
z=21 ANSI	5044938	19,05
z=23 ANSI	5044939	19,05
z=25 ANSI	5044940	19,05

## Catenary drive unit

### 0-unit – XHEC 0 HL/HR/HLA/HRA

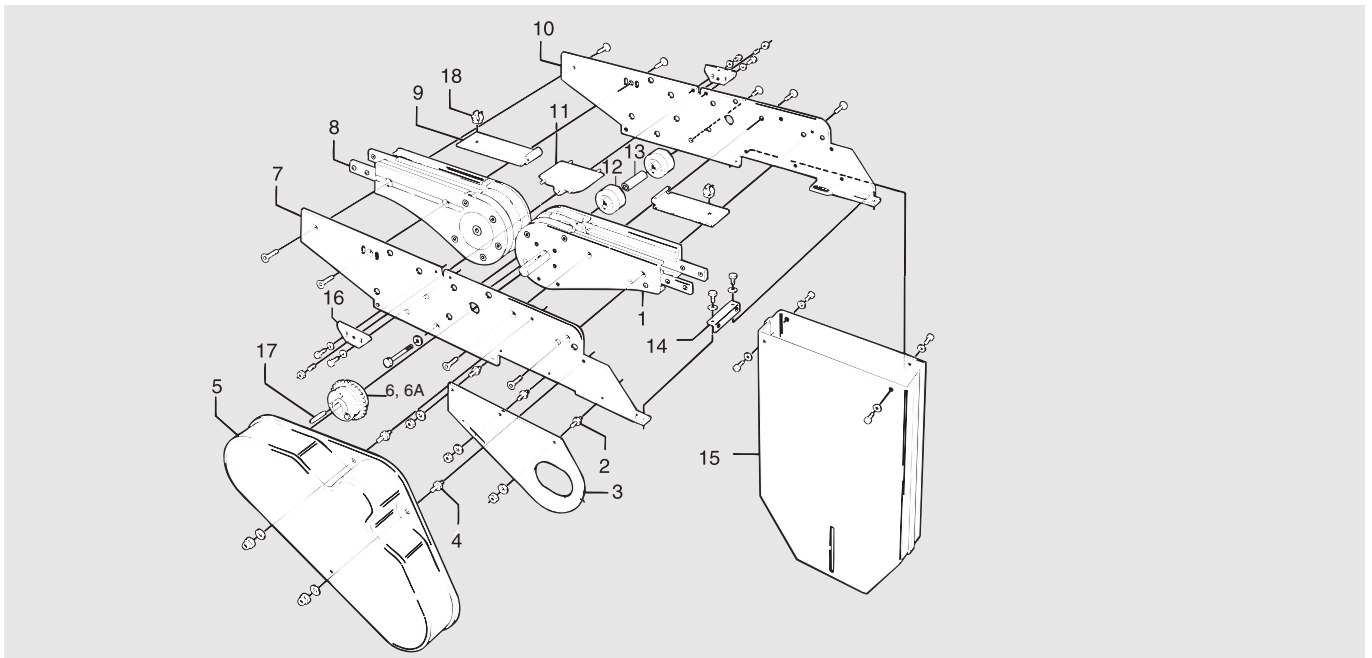

Item	Description	Part No	Qty	Comments	Recommended Spare parts
1	Basic unit (left-hand version)	XHEB 0 HLU	1	See next page for details	
	Basic unit (right-hand version)	XHEB 0 HRU	1	See next page for details	
2*	Distance screw	(3904862)	2	See kit below	
3	Chain guard	3904847	1		
4*	Distance screw	(3904855)	2	See kit below	
5	Transmission cover	3904431	1		
6	Slip clutch Ø25 mm	5053981	1	ISO	
	-Slip clutch, Spare parts kit	5056817	1	ISO, incl. cup spring, ball, chain wheel.	X
6	Slip clutch Ø25 mm	5054000	1	ANSI	
	-Slip clutch, Spare parts kit	5056820	1	ANSI, incl. cup spring, ball, chain wheel.	X
7	Motor bracket L	3921463	1		
8	Idler unit	3921481	1	See page 5 for details	
9	Cover plate	3924662	2		
10	Motor bracket R	3921464	1		
11	Bridge	3905610	1		
12	Support roller	3920087	4		
13	Distance pipe	3920010	2		
14	Adjusting block	3924287	1		
15	Cover	3902795	1		
16	Adjustment plate	3905278	2		
17	Thin parallel key	DIN 6885A h9	1	8×7×25	
18	Tube clamp	14062	2	Handimex	
*) 2	Distance screw kit	5111600	1	Kit contains 10 pcs	
*) 4	Distance screw kit	5111599	1	Kit contains 10 pcs	

## Catenary drive unit

---

Basic unit – XHEB 0 HLU/HRU

See “Basic unit – XHEB 0 HLU/HRU” on page 28

## Catenary drive unit

## Idler unit – 3921481

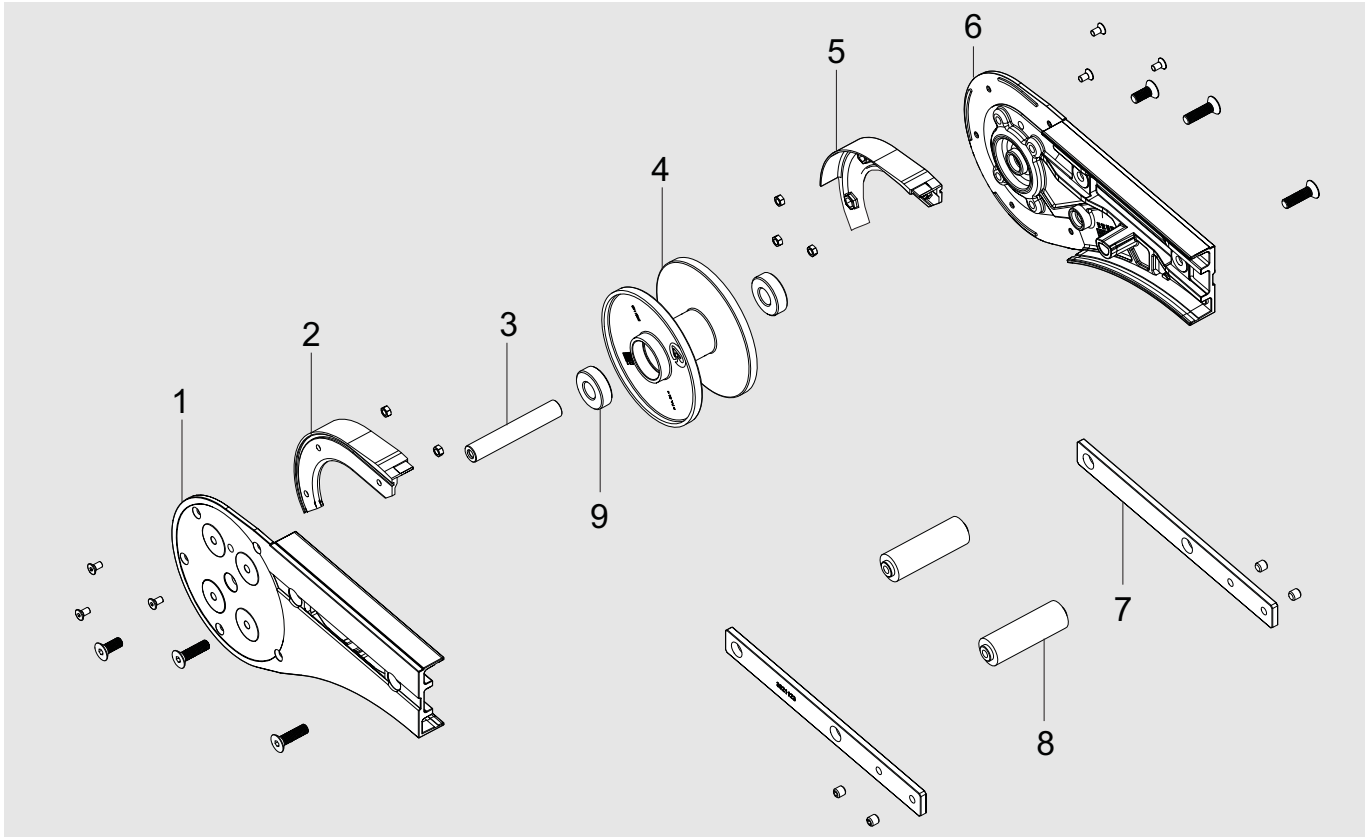

Item	Description	Part No	Qty	Comments	Recommended Spare parts
1	Side plate R	5130316	1		
2*	Steering guide	3921483	1		
3*	Shaft	(3921287)	1		
4*	Idler wheel	5111630	1	(3921163)	
5*	Steering guide	3921482	1		
6	Side plate L	5130314	1		
7	Connecting strip	3921123	2		
8	Spacer	3904140	2		
9*	Bearing	(6202-2Z)	2		
*)3+4+9	Wheel kit	5111625	1	(3924757)	X
*)2+5	Steering guide kit	5111631	1	set incl. L+R	X
*)1+6	Side plate kit	5111624	1	set incl. L+R	



# Spare parts Horizontal bend drive unit- XH

Technical information from FlexLink

XH005-E4

## Horizontal bend drive unit- XH

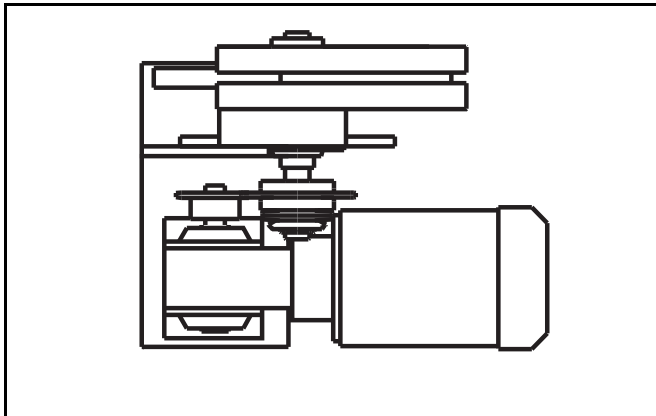

### Revision list

Document designation	Date	Type of revision	Entered by
XH005-E1	98-10-14	New version	Enator Inforum
XH005-E2	10-08-25	VP=>FM8	JE
XH005-E3	19-12-09	Updated sprocket wheel table	ML
XH005-E4	21-05-03	Updated logo and lists	TG

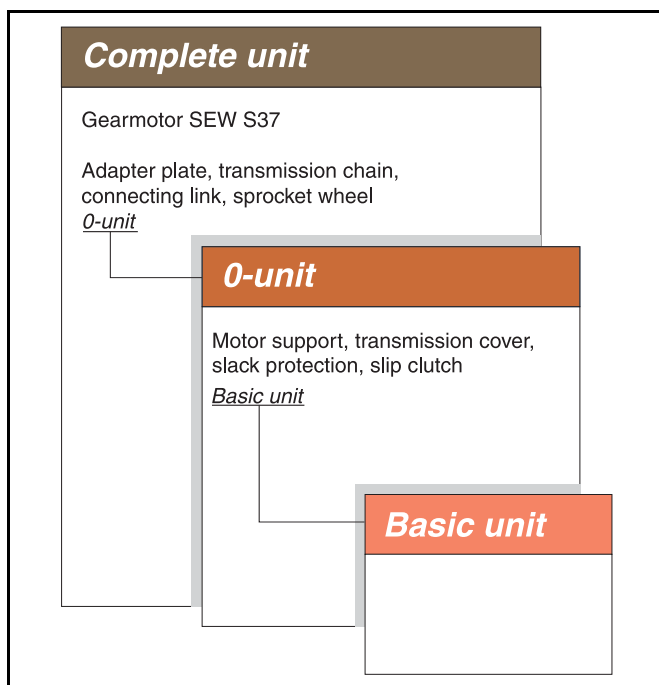

## Horizontal bend drive unit

Complete unit – XHEW 180/\_H/HA

For SEW S37 gearmotor

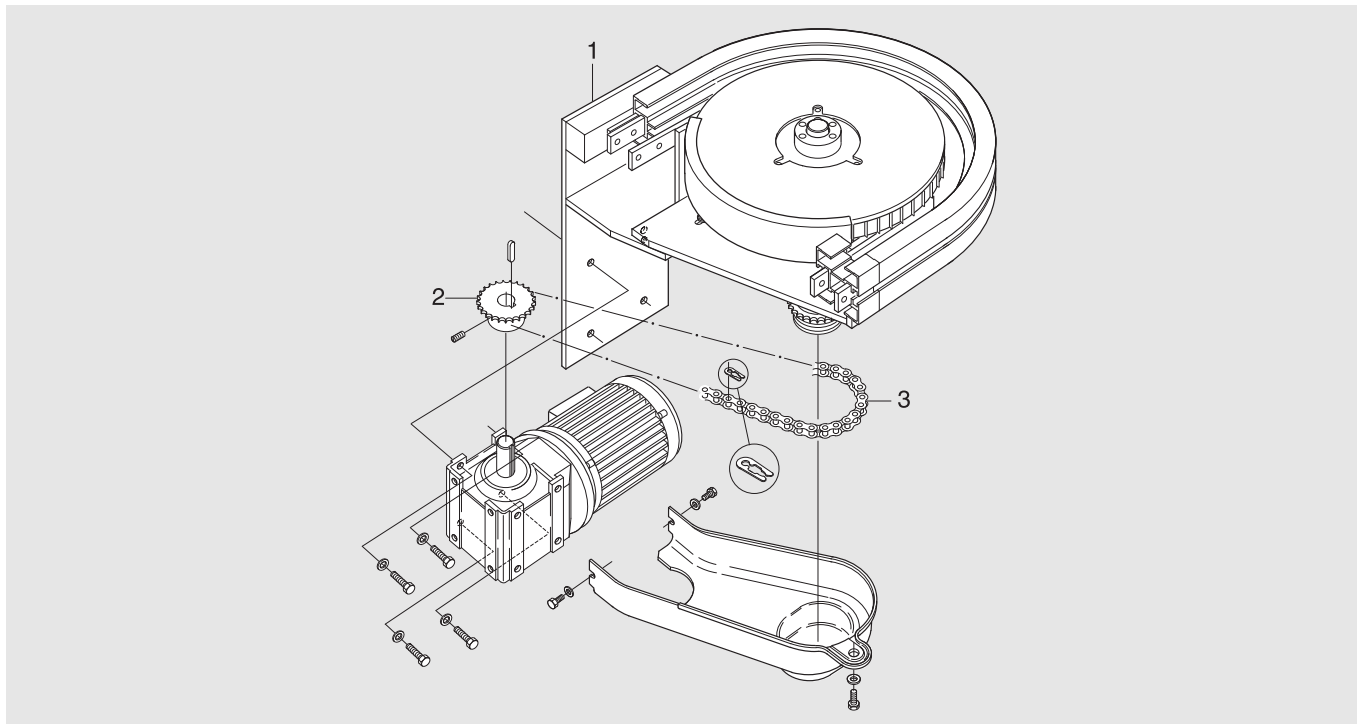

Item	Description	Part No	Qty	Comments	Recommended Spare parts
1	0-unit	XHEW 180/0 H/HA	1	See next page for details	
2	Sprocket wheel 1/2" including grub screw		1	See table below	X
3	Transmission chain 1/2" including connecting link	3921638	1	ISO/R- 1967- 08B- 1 (ISO)	X
	Transmission chain 1/2" including connecting link	5044948	1	ISO/R- 1967- 08A- 1 (ANSI)	X

## Important

Items 2-4 must be ordered separately when ordering a 0-unit (item 1). The sprocket wheel (item 2) should be specified in accordance with the following table:

Sprocket wheel 1/2"	Part No (SEW)	Shaft diameter
z=19 ISO	3924438	20
z=21 ISO	3924439	20
z=23 ISO	3924440	20
z=25 ISO	3921258	20
z=15 ANSI	5044935	19,05
z=17 ANSI	5044936	19,05
z=19 ANSI	5044937	19,05
z=21 ANSI	5044938	19,05
z=23 ANSI	5044939	19,05
z=25 ANSI	5044940	19,05

## Horizontal bend drive unit

## 0-unit – XHEW 180/0 H/HA

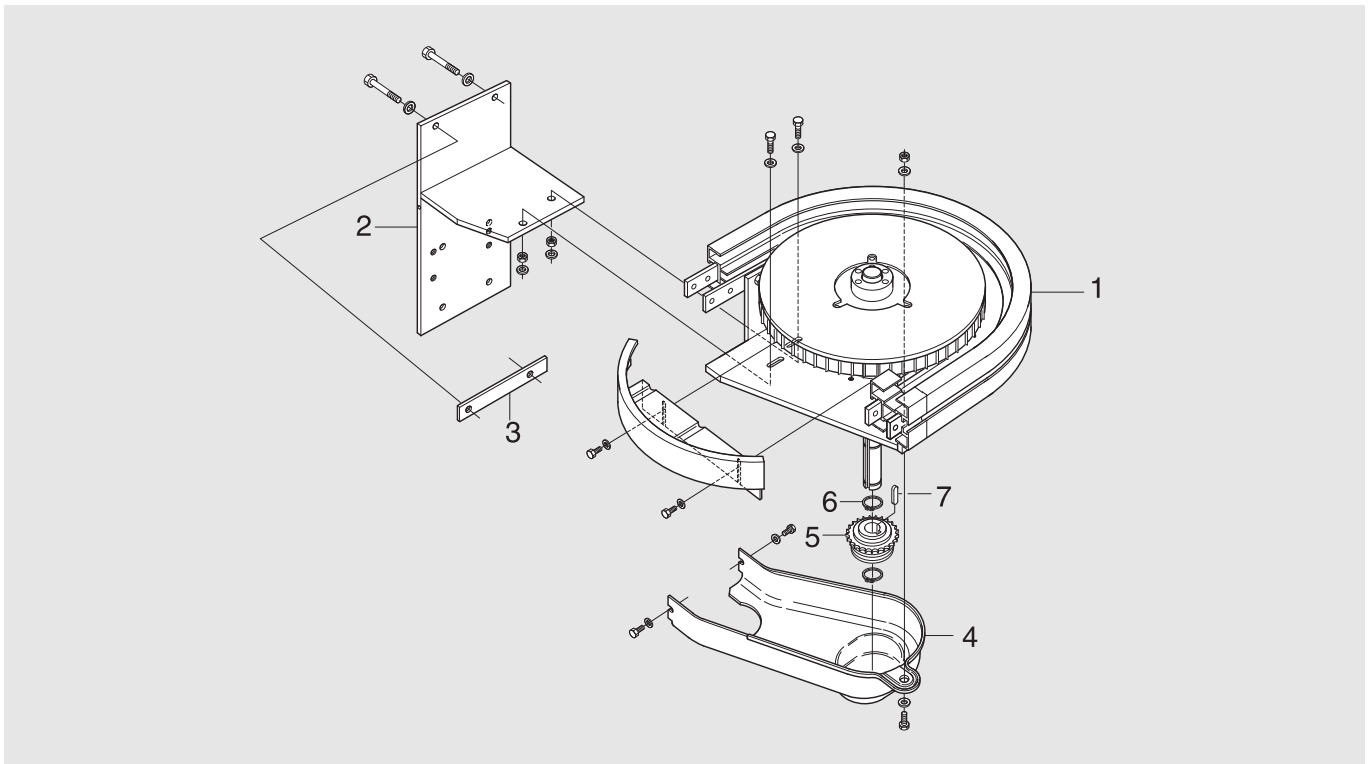

Item	Description	Part No	Qty	Comments	Recommended Spare parts
1	Basic unit	XHEW 180/0 HU	1	See next page for details	
2	Bracket	3926586	1		
3	Nut bracket	3903339	1		
4	Transmission cover	3926754	1		
5	Slip clutch Ø25 mm	5053981	1	ISO	
	-Slip clutch, Spare parts kit	5056817	1	ISO, incl. cup spring, ball, chain wheel.	X
	Slip clutch Ø25 mm	5054000	1	ANSI	
	-Slip clutch, Spare parts kit	5056820	1	ANSI, incl. cup spring, ball, chain wheel.	X
6	Retaining ring	DIN 471	2	25 st	
7	Thin parallel key	DIN 6885A h9	1	8×7×40	

## Horizontal bend drive unit

Basic unit – XHEW 180/0 HU

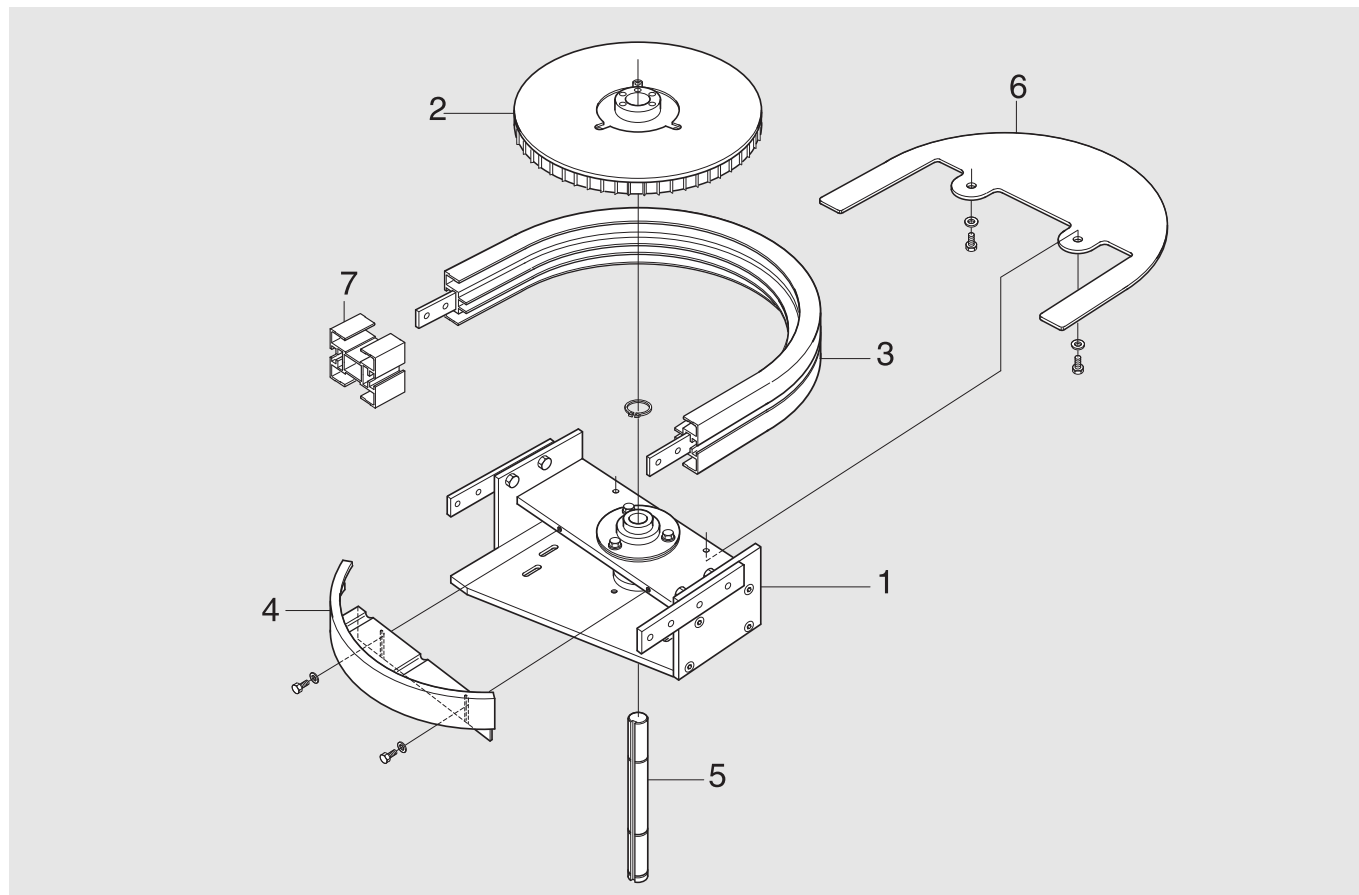

Item	Description	Part No	Qty	Comments	Recommended Spare parts
1	Bracket	3926575	1		
2	Drive wheel	3902723	1		X
3	Outer horizontal bend	XHBE 180R170	1		
4	Protective cover	3926718	1		
5	Shaft	3926450	1		
6	Cover	3926577	1		
7	Transport cover	3926716	2		

# Spare parts XHEB HNL P/HNR P

Technical information from FlexLink

5354EN-6

## End drive unit XH Type H, direct drive without slip clutch

### Revision list

Document designation	Date	Type of revision	Entered by
5354EN-1	06-06-30	Initial version	
5354EN-2	10-08-30	Added new column	CB
5354EN-3	15-08-19	BOM XHEB 0 HNLGP/HNRGP added	KR
5354EN-4	21-05-03	Updated logo and lists	TG
5354EN-5	23-11-08	Updated slack protection HNL P	TG
5354EN-6	23-12-14	Drive wheel kit added	TG

### Complete unit XHEB # HNL P/HNR P

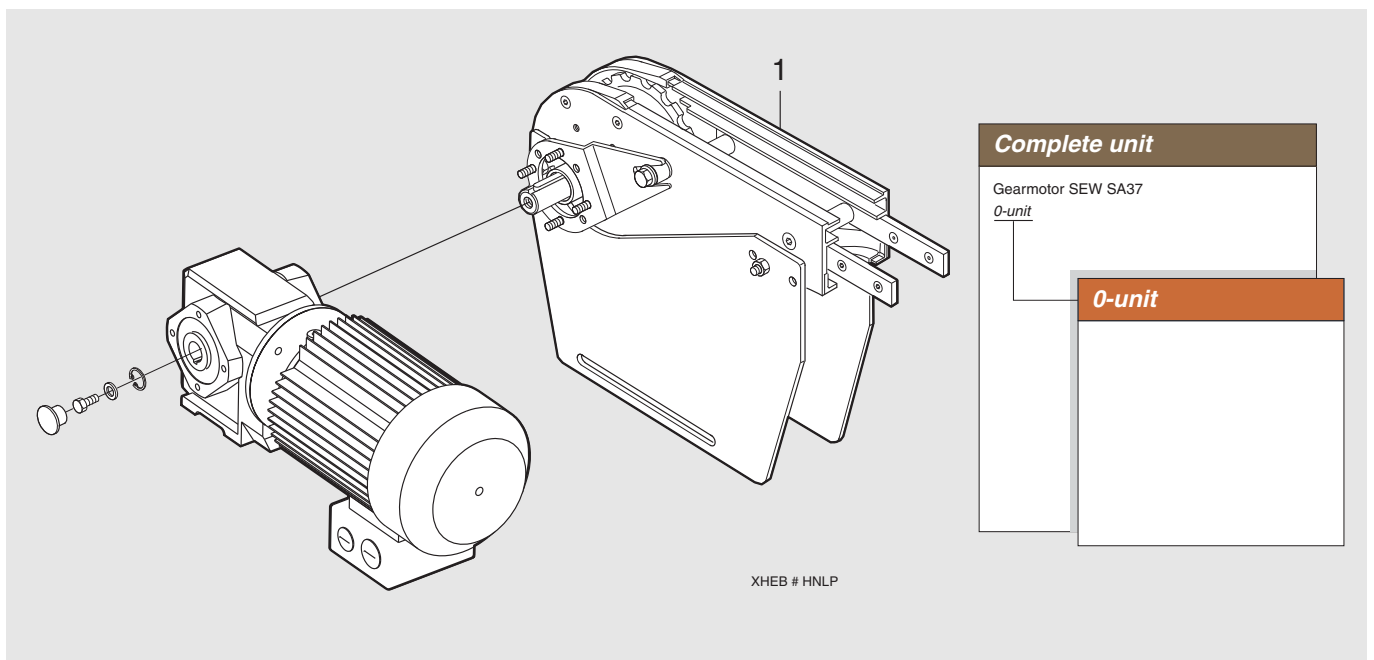

Item	Description	Part No	Qty	Comments	Recommended Spare parts
1	0-unit (left-hand version)	XHEB 0 HNL P	1	See next page for details	
	0-unit (right-hand version)	XHEB 0 HNR P	1	See next page for details	
	0-unit (left-hand version)	XHEB 0 HNLGP	1	See Page 37 for details	
	0-unit (right-hand version)	XHEB 0 HNRGP	1	See Page 37 for details	
For SEW SA37 gearmotor					

## 0-unit XHEB 0 HNLP/HNRP

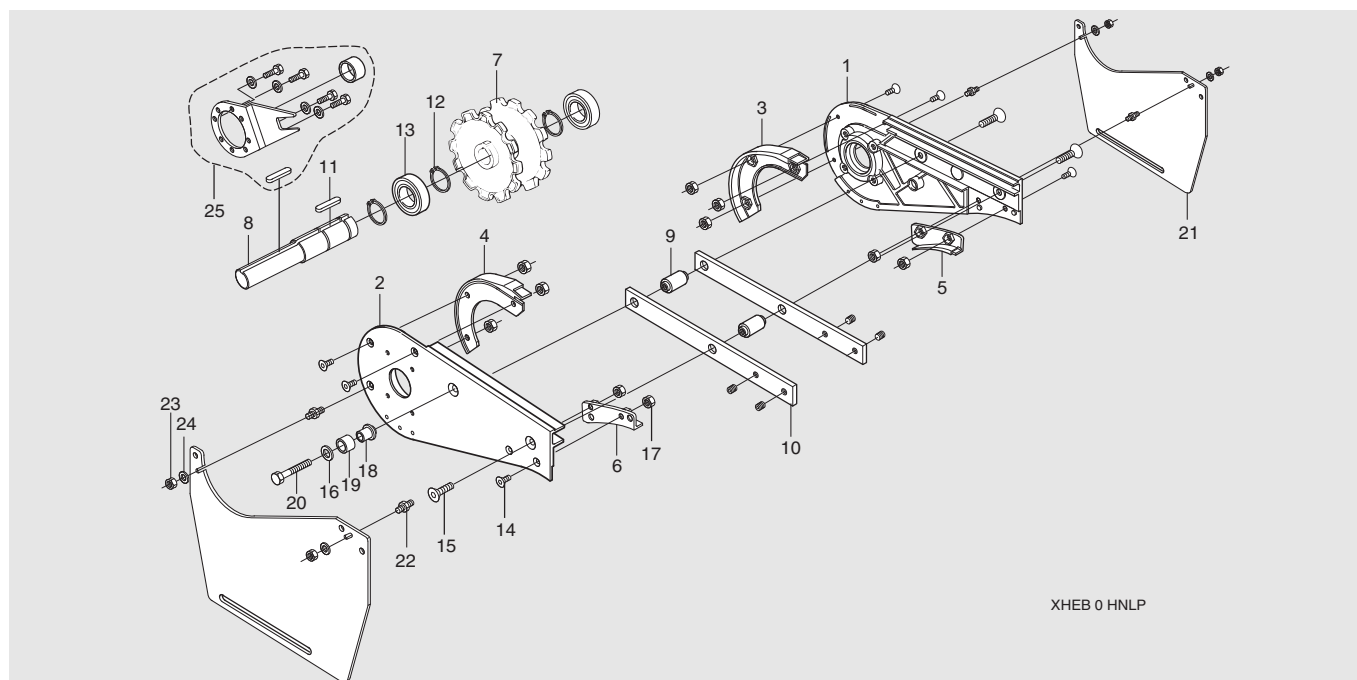

Item	Description	Part No	Qty	Comments	Recommended Spare parts
1	Side plate R	3904234	1		
2	Side plate L	3904746	1		
3*	Steering guide R	3904312	1		
4*	Steering guide L	3904745	1		
5*	Guide R	3904313	1		
6*	Guide L	3904744	1		
7*	Drive wheel	5111627	1	(3904299)	X
8	Shaft	5057047	1		
9	Spacer	3904140	2		
10	Connecting strip	3921123	2		
11	Wedge	DIN 6885 A h9	1	8x7-63	
12	Retaining ring	DIN 471	2	25 st	
13	Bearing	6205 2RS1/C3	2		
14	Screw	ISO 10642	6	M5X10 10,9 A2K	
15	Screw	ISO 10642	3	M8x30 10,9 A2K	
16	Washer for torque arm	5056635	1		
17	Nut	ISO 4032	10	M5 A2K	
18	Sleeve	5043873	1		
19	Torque absorber	5043874	1		
20	Screw	ISO 4014	1	M8X45 8,8 A2K	
21*	Slack protection	(3925673)	2		
22	Distance screw M5/M6	3925718	4		
23	Nut	ISO 4032	4	M6 A2K	
24	Washer	ISO 7089	4	6.4X12X1,6 A2K	
25	Torque arm kit	5057039	1	Torque arm, cover, screws, washers, wedge	
*) 3+4	Spare parts kit Steering guide	5111629	1		X
*) 5+6	Spare parts kit Guide	5111622	1		X
*) 21	Slack protection kit	FLX1009587	1	LH+RH	

## 0-unit XHEB 0 HNLGP/HNRGP

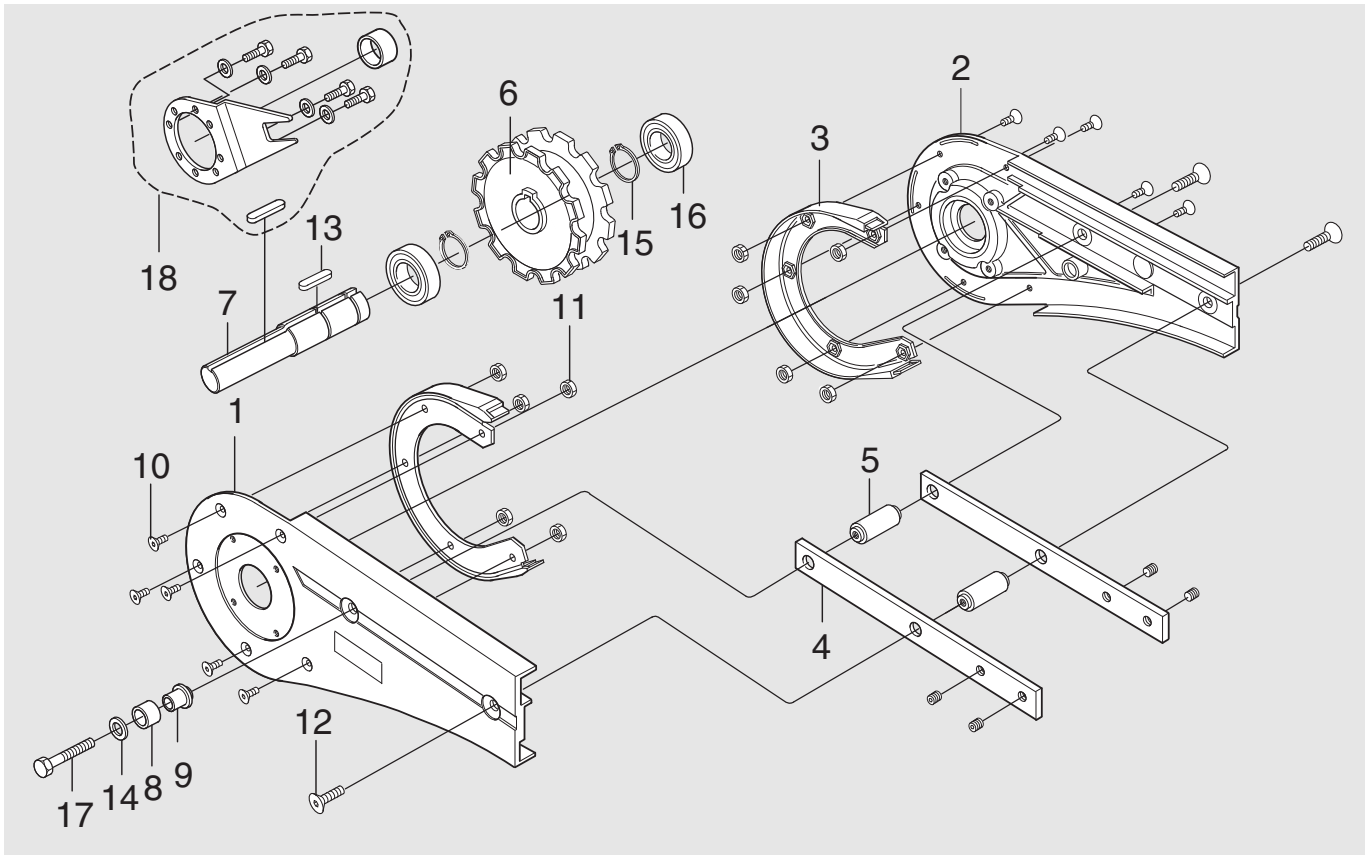

Item	Description	Part No	Qty	Comments	Recommended Spare parts
1*	Side plate L	3921685	1		
2*	Side plate R	3921684	1		
3*	Steering guide R	3921164	2		
4	Connecting strip	3921123	2		
5	Spacer	3904140	2		
6*	Drive wheel	5111627	1	(3904299)	X
7	Shaft	5057047	1	XH SEW SA37	
8	Torque absorber	5043874	1		
9	Sleeve	5043873	1		
10	Screw	ISO 10642	10	M5X10 10,9 A2K	
11	Nut	ISO 4032	10	M5 A2K	
12	Screw	ISO 10642	3	M8x30 10,9 A2K	
13	Thin parallel key	DIN 6885 A h9	1	8x7x50	
14	Washer for torque arm	5056635	1		
15	Retaining ring	DIN 471	2	25 St	
16	Bearing	6205 2RS1/C3	2		
17	Screw	ISO 4014	1	M8X45 8,8 A2K	
18	Torque arm kit	5057039	1	Torque arm, cover, screws, washers, wedge, sleeve	
*) 1+2	Side plate kit	5111634	1		X
*) 3	Steering guide kit	5111626	1		X
*) 8+9+14+17	Absorber kit	5118620	1		



# Spare parts Idler end unit- XH

Technical information from FlexLink

XH006-E3

## Idler end unit- XH

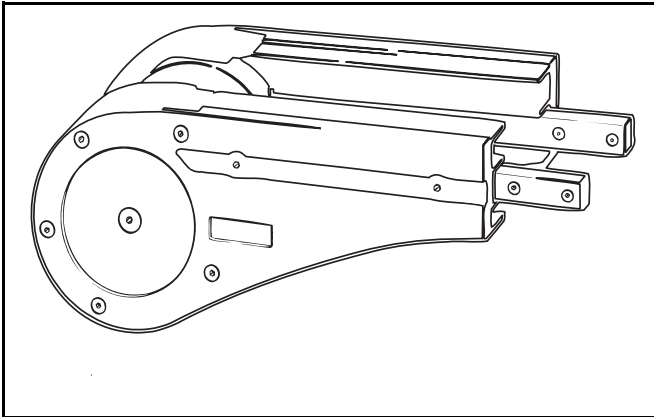

### Revision list

Document designation	Date	Type of revision	Entered by
XH006-E1	98-10-14	New version	Enator Inforum
XH006-E2	21-05-03	Updated logo	TG
XH007-E3	22-01-19	New no. Side plates	TG

## Idler end unit

## XHEJ 325

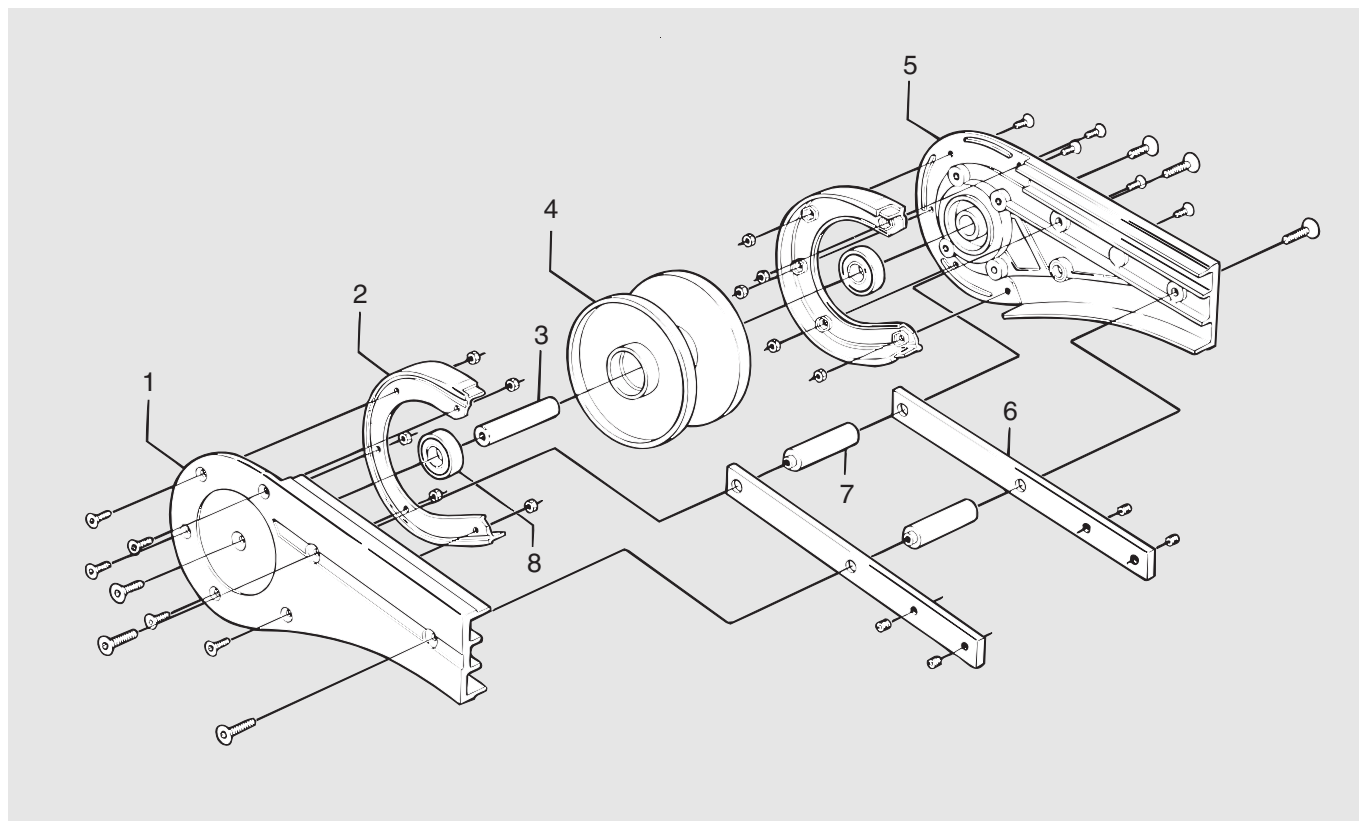

Item	Description	Part No	Qty	Comments	Recommended Spare parts
1	Side plate R	5130316	1		
2	Spare parts kit Steering guide	5111626	1	(3921164)	X
3*	Shaft	(3921287)	1		
4*	Idler wheel	5111630	1	(3921163)	
5	Side plate L	5130314	1		
6	Connecting strip	3921123	2		
7	Spacer	3904140	2		
8*	Bearing	(6202-2Z)	2		
*) 3+4+8	Wheel kit	5111625	1		X
*) 1+5	Side plate kit	5111624	1		

# Spare parts X\_BH

Wheel bends XSBH-, XLBH-, XBBH-, XMBH-, XHBH-, XKBH-, XTBH-

## Complete wheel bend

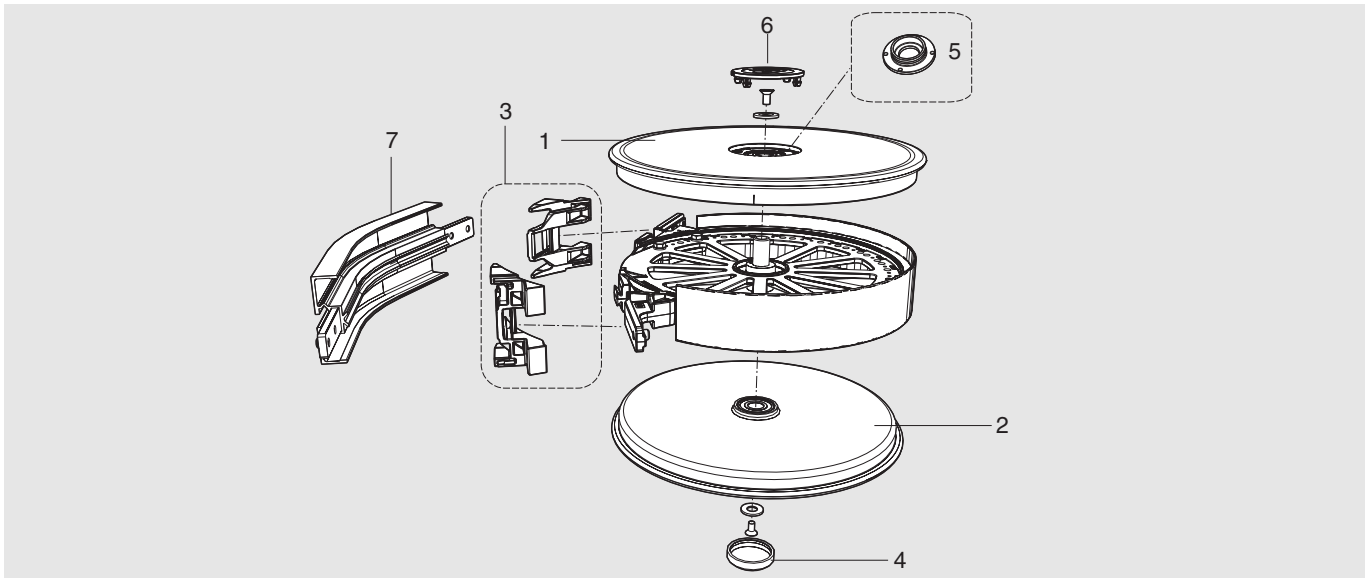

Item	Description	Part no							Recommended Spare parts
		XS	XL type A	X85	XM type A	XH type A	XK	XT	
1	Wheel disc* (upper)	3902168	5059247	5059247	5059247	5059247	3924966	5059247	
2	Wheel disc* (lower)	3902168	5059244	5059244	5059244	5059244	3924966	5059244	
3	Guides kit**	n.a.	5059235 (2pcs of 5057693)	5110507 (2pcs of 5059483)	5059236 (2pcs of 5057694)	5059237 (2pcs of 5057695)	n.a.	n.a.	X
4	Wheel cover	3901120	3901120	3901120	3901120	3901120	3901120	3901120	
5	Adapter kit	n.a.	5058559	5058559	5058559	5058559	3925714	5058559	
6	Wheel cover	5057697	5057697	5057697	5057697	5057697	n.a.	5057697	
7	Outer bend	XSBE 30R150	XLBE 30R150	XBBE 30A85R160	XMBE 30R160	XHBE 30R170	XKBE 30R200		
7	Outer bend	XSBE 45R150	XLBE 45R150	XBBE 45A85R160	XMBE 45R160	XHBE 45R170	XKBE 45R200	5048240	
7	Outer bend		XLBE 60R150		XMBE 60R160	XHBE 60R170			
7	Outer bend	XSBE 90R150	XLBE 90R150	XBBE 90A85R160	XMBE 90R160	XHBE 90R170	XKBE 90R200	5048482	
7	Outer bend	XSBE 180R150	XLBE 180R150	XBBE 180A85R160	XMBE 180R160	XHBE 180R170	XKBE 180R200	5048485	
7	Outer bend			XBBE EA85R160					
*	Including bearings								
**	One pair								

This page is intentionally left blank

# Spare parts Slide rails- XH

Technical information from FlexLink

## Spare parts Slide rails- XH

Slide rails – XH

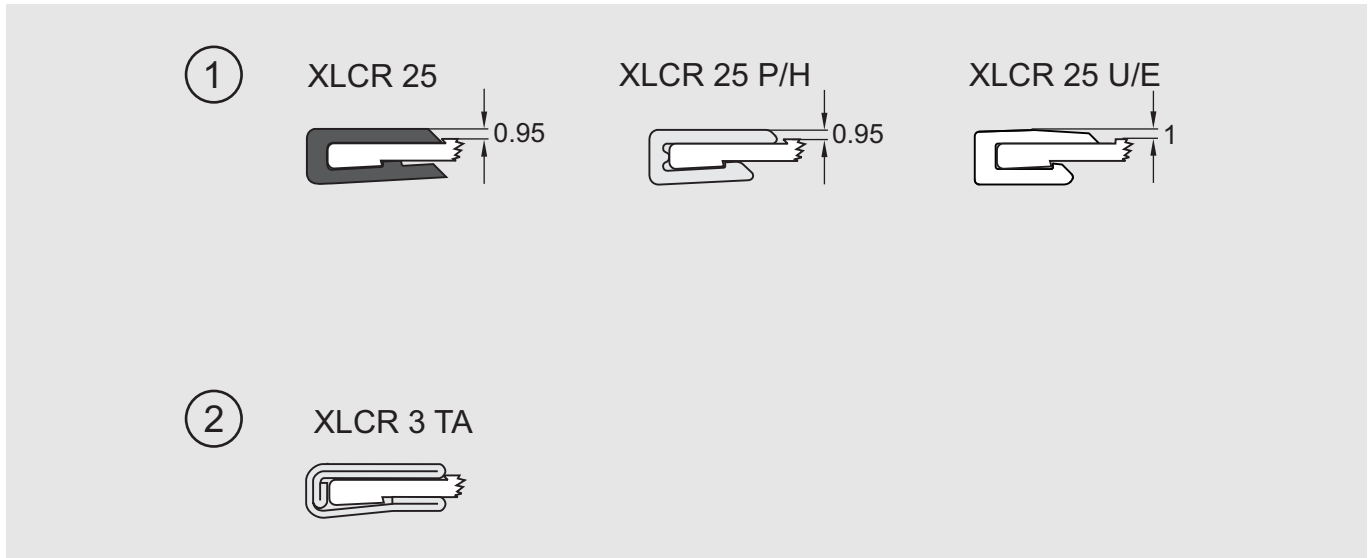

Item	Description	Part No	Qty	Comments	Recommended Spare parts
1	Plastic slide rails for XL, XH beams				
	HDPE ( $\mu=0,1-0,25$ ) (Black)	XLCR 25			
	PVDF ( $\mu=0,15-0,35$ ) (Transparent white)	XLCR 25 P			
	UHMW-PE ( $\mu=0,1-0,25$ ) (White)	XLCR 25 U			
	PA-PE ( $\mu=0,1-0,25$ ) (Grey)	XLCR 25 H			
	PE-UHMW conductive (Black)	XLCR 25 E			
2	Steel slide rail for XL, X85, XH beams				
	Slide rail ( $\mu=0,15-0,35$ )	XLCR 3 TA		Acid resistant stainless steel	



## Spare parts Chains- XH

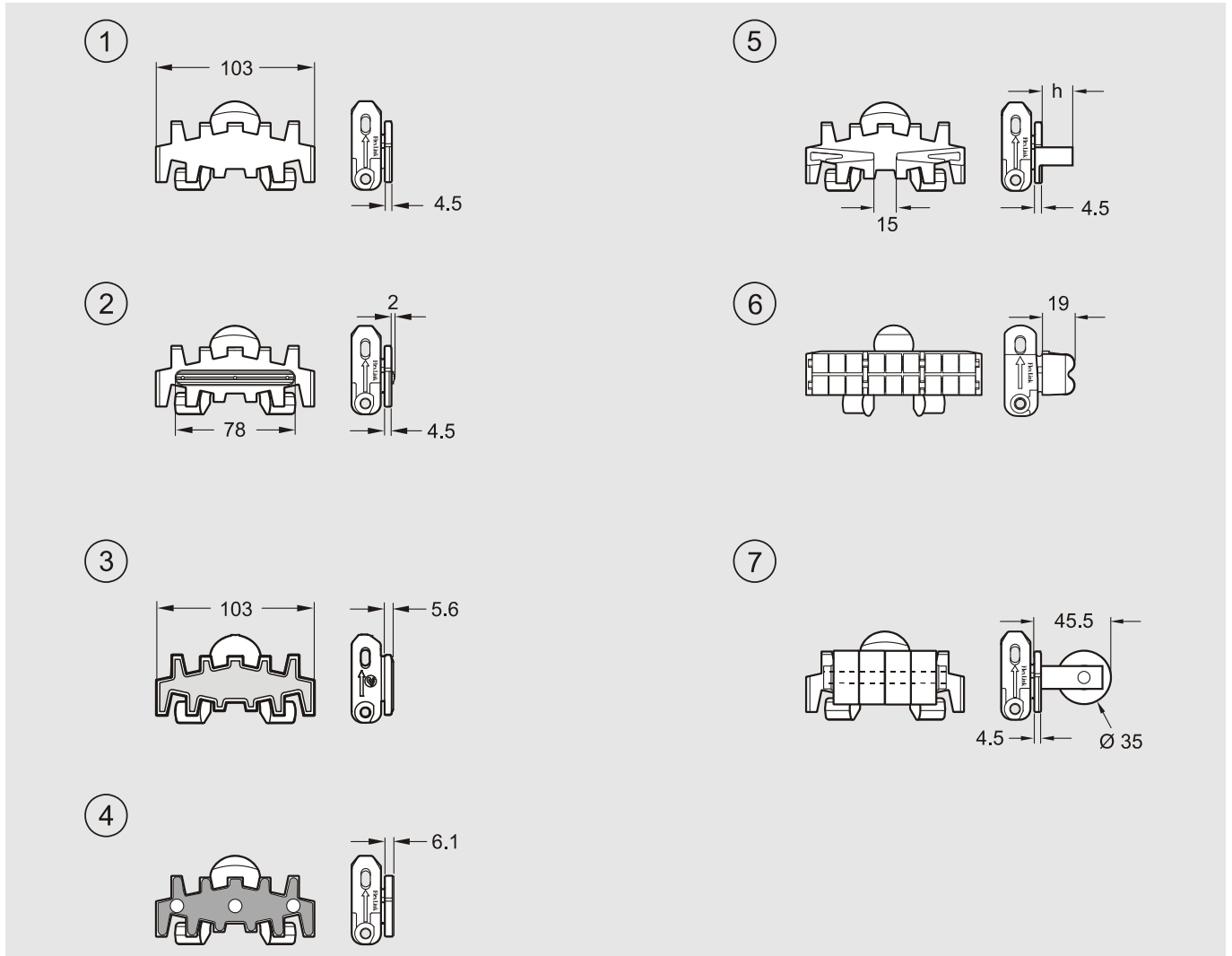

Item	Description	Part No	Qty	Comments	Recommended Spare parts (Based on previous chain in the Conveyor system)
1	Plain chain	XHTP 5			
	Plain link kit	5056312		Link kit contains 10 links, 10 pivots, 10 steel pins	
	Plain chain, (Ultra low wear)	XHTP 5 C			
	Plain link (Ultra low wear)	n.a.			
2	Friction top chain	XHTP 5 F#		Enter cleat frequency (1–10) instead of # in product designation	
	Friction top link kit	5056593		Link kit contains 10 links, 10 pivots, 10 steel pins	

Item	Description	Part No	Qty	Comments	Recommended Spare parts (Based on previous chain in the Conveyor system)
3	Flat top friction chain	XHTP 5 FA			
	Flat top friction link kit	5058544			
4	Steel top chain	XHTP 5 TF			
	Steel top link kit	5056594		Link kit contains 10 links, 10 pivots, 10 steel pins	
5	Cleated chain, Type A			Enter cleat frequency (1–20) instead of # in product designation	
	h=15 mm	XHTF 5x15 A#			
	h=20 mm	XHTF 5x20 A#			
	h=30 mm	XHTF 5x30 A#			
	h=40 mm	XHTF 5x40 A#			
	Cleated link kit				
	h=15 mm	5056595		Link kit contains 10 links, 10 pivots, 10 steel pins	
	h=20 mm	5056596		Link kit contains 10 links, 10 pivots, 10 steel pins	
	h=30 mm	5056597		Link kit contains 10 links, 10 pivots, 10 steel pins	
	h=40 mm	5056598		Link kit contains 10 links, 10 pivots, 10 steel pins	
6	Roller top chain	XHTR 5			
	Roller top link kit	5056603		This link cannot be combined with plain links. Link kit contains 10 links, 10 pivots, 10 steel pins	
7	Chain with roller cleats	XHTF 5x46 R#		Enter cleat frequency (1–20) instead of # in product designation	
	Link kit with roller cleats	5056604		1 link XHTL 103x46 R with pivot and steel pin	

## Spare parts Guide rail cover- XH

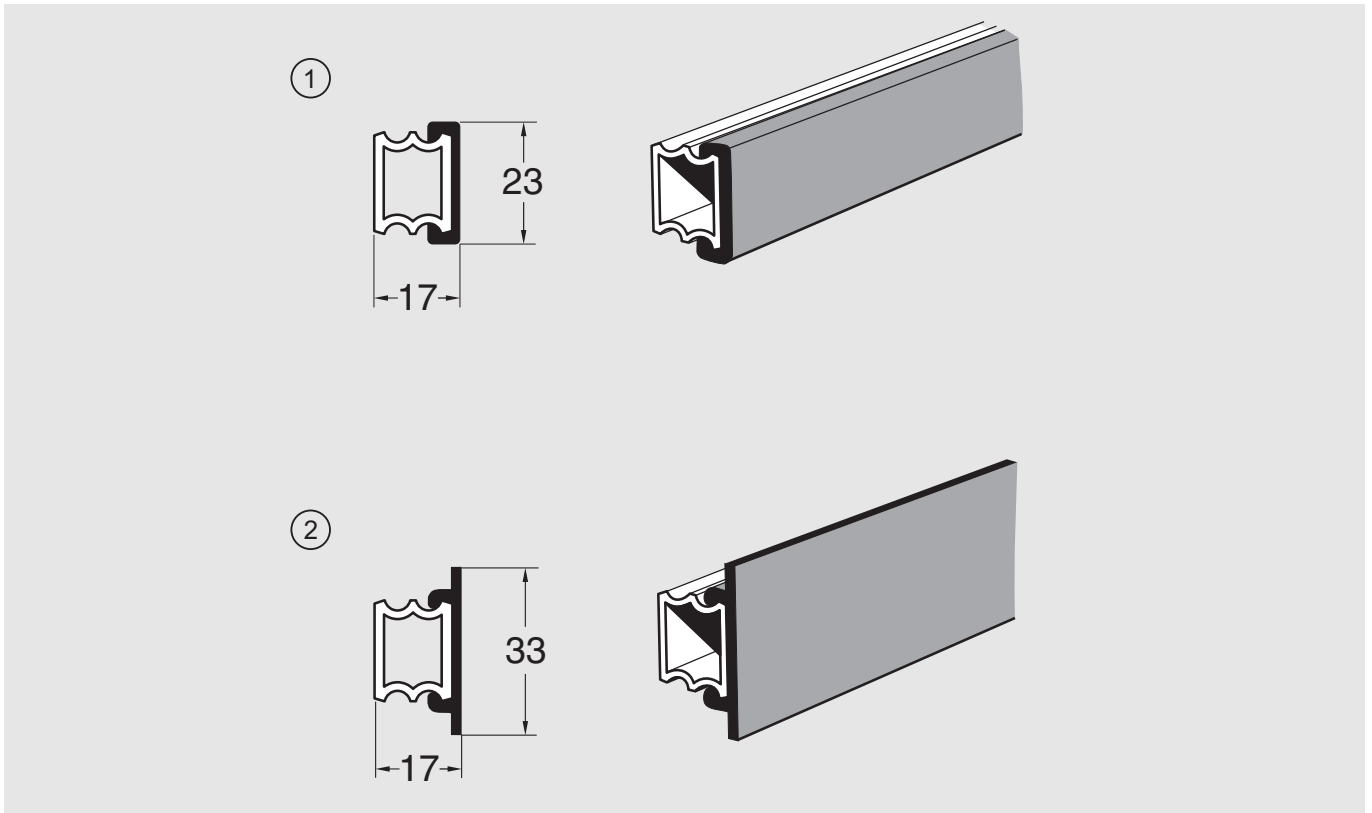

Item	Description	Part No	Qty	Comments	Recommended Spare parts
1	Guide rail cover for 15 mm aluminium guide rail				
	Polyethylene, length 3 m	XLRT 3×23			
	UHMW-PE, length 3 m	XLRT 3×23 U			
2	Guide rail cover, flanged, for 15 mm aluminium guide rail				
	Polyethylene, length 3 m, flanged	XLRT 3×33 D			



## Product designations in alphanumeric order

(3902527) .....	24	3901120 .....	41
(3902661) .....	24	3902168 .....	41
(3904312) .....	18	3902723 .....	34
(3904312) .....	4	3902795 .....	27
(3904313) .....	18	3903339 .....	33
(3904313) .....	24	3904139 .....	18
(3904313) .....	4	3904140 .....	13
(3904403) .....	13	3904140 .....	18
(3904403) .....	4	3904140 .....	29
(3904665) .....	17	3904140 .....	36
(3904665) .....	20	3904140 .....	37
(3904665) .....	23	3904140 .....	4
(3904665) .....	3	3904140 .....	40
(3904665) .....	6	3904234 .....	36
(3904666) .....	17	3904299 .....	36
(3904666) .....	20	3904299 .....	37
(3904666) .....	23	3904312 .....	36
(3904666) .....	3	3904313 .....	36
(3904666) .....	6	3904431 .....	12
(3904666) .....	6	3904431 .....	17
(3904744) .....	18	3904431 .....	20
(3904744) .....	24	3904431 .....	23
(3904744) .....	4	3904431 .....	27
(3904745) .....	18	3904431 .....	3
(3904745) .....	4	3904431 .....	6
(3904855) .....	10	3904527 .....	12
(3904855) .....	12	3904527 .....	17
(3904855) .....	17	3904527 .....	20
(3904855) .....	20	3904527 .....	3
(3904855) .....	23	3904528 .....	12
(3904855) .....	27	3904528 .....	17
(3904855) .....	3	3904528 .....	20
(3904855) .....	6	3904528 .....	3
(3904862) .....	10	3904744 .....	36
(3904862) .....	12	3904745 .....	36
(3904862) .....	17	3904746 .....	36
(3904862) .....	20	3904847 .....	27
(3904862) .....	23	3905278 .....	27
(3904862) .....	27	3905278 .....	6
(3904862) .....	3	3905610 .....	27
(3904862) .....	6	3905610 .....	6
(3921164) .....	13	3920010 .....	27
(3921287) .....	29	3920084 .....	8
(3921287) .....	40	3920087 .....	27
(3924634) .....	24	3920751 .....	10
(3925673) .....	20	3920903 .....	10
(3925673) .....	36	3920904 .....	10
(3925673) .....	8	3921123 .....	13
(3925718) .....	8	3921123 .....	29
(3925875) .....	12	3921123 .....	36
(5130476) .....	13	3921123 .....	37
(5130477) .....	13	3921123 .....	4
(5130506) .....	18	3921123 .....	40
(5130506) .....	4	3921164 .....	37
(5130578) .....	18	3921463 .....	27
(5130578) .....	4	3921463 .....	6

3921464	27	5043873	37
3921464	6	5043874	36
3921481	27	5043874	37
3921482	29	5044695	20
3921483	29	5044948	16
3921638	16	5044948	19
3921638	19	5044948	2
3921638	2	5044948	22
3921638	22	5044948	26
3921638	26	5044948	32
3921638	32	5046915	20
3921652	8	5046917	20
3921684	37	5048240	41
3921685	37	5048482	41
3924197	11	5048485	41
3924197	16	5053981	10
3924197	19	5053981	12
3924197	2	5053981	17
3924197	22	5053981	20
3924197	26	5053981	23
3924197	9	5053981	27
3924287	10	5053981	3
3924287	12	5053981	33
3924287	27	5053981	6
3924287	3	5054000	10
3924287	6	5054000	12
3924455	11	5054000	17
3924455	9	5054000	20
3924662	27	5054000	23
3924966	41	5054000	27
3924975	24	5054000	3
3925469	20	5054000	33
3925714	41	5054000	6
3925718	20	5054003	8
3925718	36	5056312	45
3926277	18	5056593	45
3926279	17	5056594	46
3926310	17	5056595	46
3926311	18	5056596	46
3926374/		5056597	46
3927191	10	5056598	46
3926375	10	5056603	46
3926450	34	5056604	46
3926575	34	5056635	36
3926577	34	5056635	37
3926586	33	5056817	10
3926716	34	5056817	12
3926718	34	5056817	17
3926754	33	5056817	20
3926790	24	5056817	23
3926791	24	5056817	27
3927119	24	5056817	3
3927121	24	5056817	33
3927122	24	5056817	6
3927180	24	5056820	10
3927181	24	5056820	12
5043873	36	5056820	17

SPARE PARTS

5056820	20	5111627	18
5056820	23	5111627	36
5056820	27	5111627	37
5056820	3	5111627	4
5056820	33	5111628	18
5056820	6	5111628	4
5057039	36	5111629	18
5057039	37	5111629	36
5057047	36	5111629	4
5057047	37	5111630	29
5057697	41	5111630	40
5058544	46	5111631	29
5058559	41	5111632	13
5059235	41	5111632	4
5059236	41	5111634	13
5059237	41	5111634	37
5059244	41	5117108	7
5059247	41	5118620	37
5110507	41	5130314	29
5111566	17	5130314	40
5111566	20	5130316	29
5111566	23	5130316	40
5111566	3	XBBE 180A85R160	41
5111566	6	XBBE 30A85R160	41
5111581	20	XBBE 45A85R160	41
5111581	8	XBBE 90A85R160	41
5111598	8	XBBE EA85R160	41
5111599	10	XH SEW SA37	37
5111599	12	XHBE 180R170	34
5111599	17	XHBE 180R170	41
5111599	20	XHBE 30R170	41
5111599	23	XHBE 45R170	41
5111599	27	XHBE 60R170	41
5111599	3	XHBE 90R170	41
5111599	6	XHEB 0 HL/HLA	2
5111600	10	XHEB 0 HLD/HLAD-	19
5111600	12	XHEB 0 HLD/HLAD106	16
5111600	17	XHEB 0 HLDU-	20
5111600	20	XHEB 0 HLDU106	17
5111600	23	XHEB 0 HLG/HLAG	11
5111600	27	XHEB 0 HLGU	12
5111600	3	XHEB 0 HLGU	8
5111600	6	XHEB 0 HLJ/HLAJ	5
5111608	12	XHEB 0 HLP/HLGP	7
5111621	24	XHEB 0 HLU	10
5111622	18	XHEB 0 HLU	27
5111622	24	XHEB 0 HLU	3
5111622	36	XHEB 0 HLU	6
5111622	4	XHEB 0 HLU	8
5111623	24	XHEB 0 HNLGP	35
5111624	29	XHEB 0 HNLP	35
5111624	40	XHEB 0 HNRGP	35
5111625	29	XHEB 0 HNRP	35
5111625	40	XHEB 0 HR/HRA	2
5111626	13	XHEB 0 HRD/HRAD-	19
5111626	37	XHEB 0 HRD/HRAD106	16
5111626	40	XHEB 0 HRDU-	20
5111627	13	XHEB 0 HRDU106	17

XHEB 0 HRG/HRAG .....	11	XSBE 45R150 .....	41
XHEB 0 HRGU .....	12	XSBE 90R150 .....	41
XHEB 0 HRGU .....	8		
XHEB 0 HRJ/HRAJ .....	5		
XHEB 0 HRP/HRGP .....	7		
XHEB 0 HRU .....	10		
XHEB 0 HRU .....	27		
XHEB 0 HRU .....	3		
XHEB 0 HRU .....	6		
XHEB 0 HRU .....	8		
XHEC 0 HL/HLA .....	26		
XHEC 0 HR/HRA .....	26		
XHEH 0 HL/HLA .....	9		
XHEH 0 HR/HRA .....	9		
XHEJ 325 .....	6		
XHER 0 HL/HLA .....	22		
XHER 0 HLU .....	23		
XHER 0 HR/HRA .....	22		
XHER 0 HRU .....	23		
XHEW 180/0 H/HA .....	32		
XHEW 180/0 HU .....	33		
XHTF 5x15 A# .....	46		
XHTF 5x20 A# .....	46		
XHTF 5x30 A# .....	46		
XHTF 5x40 A# .....	46		
XHTF 5x46 R# .....	46		
XHTP 5 .....	45		
XHTP 5 C .....	45		
XHTP 5 F# .....	45		
XHTP 5 FA .....	46		
XHTP 5 TF .....	46		
XHTR 5 .....	46		
XKBE 180R200 .....	41		
XKBE 30R200 .....	41		
XKBE 45R200 .....	41		
XKBE 90R200 .....	41		
XLBE 180R150 .....	41		
XLBE 30R150 .....	41		
XLBE 45R150 .....	41		
XLBE 60R150 .....	41		
XLBE 90R150 .....	41		
XLCR 25 .....	43		
XLCR 25 E .....	43		
XLCR 25 H .....	43		
XLCR 25 P .....	43		
XLCR 25 U .....	43		
XLCR 3 TA .....	43		
XLRT 3x23 .....	47		
XLRT 3x23 U .....	47		
XLRT 3x33 D .....	47		
XMBE 180R160 .....	41		
XMBE 30R160 .....	41		
XMBE 45R160 .....	41		
XMBE 60R160 .....	41		
XMBE 90R160 .....	41		
XSBE 180R150 .....	41		
XSBE 30R150 .....	41		