

# Spare parts



a coesia company

5950EN-03

## Spiral Elevator Compact X85

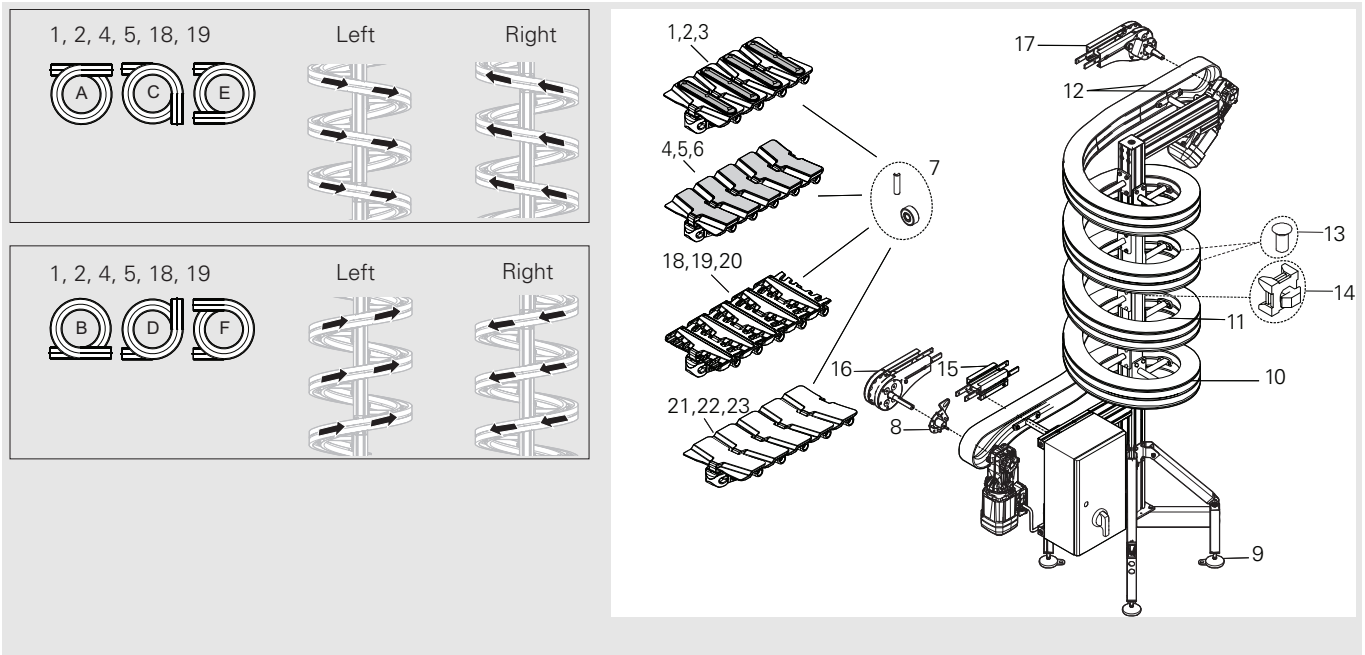

Item	Description	Part No	Qty	Comments	Recommended spare parts
1	Friction top Chain - Right	FLX1000776	3 m	(*) qty needed: Windings 4, 4,25 or 4,5: 6pcs 5, 5,25 or 5,5: 7pcs 6, 6,25, or 6,5: 8pcs	
2	Friction top Chain - Left	FLX1000774	3 m	*	
3	Link kit Friction top Chain - 10 links	FLX1000744	1	FLX1000745 included	X
4	Flat friction top chain- Right	FLX1005963	3 m	*	
5	Flat friction top chain- Left	FLX1005964	3 m	*	
6	Link kit Flat Friction top Chain - 10 links	FLX1005969	1	FLX1000745 included	X
7	Ball bearing kit	FLX1000745	1	10x bearings & pins	
8	Torque arm kit	FLX1000771	1		
9	Adjustable foot	FLX1000782	1		
10	Slide rail - outer edge	XBCR 25 H	25 m		X
11	Slide rail - inner edge	XTCR 25 H	25 m		
12	Slide rail - drive	5131199	2 m	4 m needed for both drives	
13	Rivet	XLAH 3x6	250		
14	Cable holder	TCCH 22x22 B	10		
15	Chain insert	FLX1000825	1		
16	End drive unit (Upper: Type B, D, F Lower: Type A, C, E)	FLX1004365	1	No motor included	
17	End drive unit (Upper: Type A, C, E Lower: Type B, D, F)	FLX1004366	1	No motor included	
18	Cleated chain- Right	FLX1006080	3 m	*	
19	Cleated chain- Left	FLX1006081	3 m	*	
20	Link Kit Cleated chain	FLX1006078	1	FLX1000745 included	X
21	Plain chain - Right	FLX1007997	3 m	*	
22	Plain chain - Left	FLX1007998	3 m	*	

Item	Description	Part No	Qty	Comments	Recommended spare parts
23	Link kit plain chain-10 links	FLX1008000	1	FLX1000745 included	X
24	Drive wheel kit X85	5111176	1		X
25	Drive wheel X85	5111617	1		
26	Guide kit	5111174	1		X
27	Absorber kit	5111548	1		X