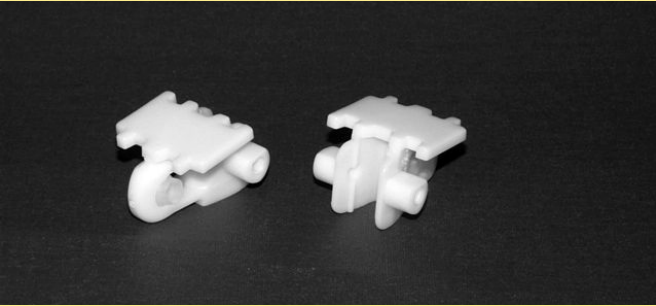
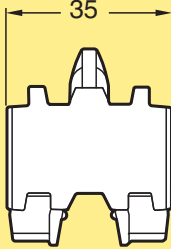
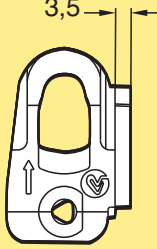

Conveyor system XT – links and chains

Each link kit contains 10 links, 10 plastic pivots, and 10 stainless steel pins, unless otherwise specified. Material abbreviations: See page III.

Plain chain

						
Chain	Link(s)	Link kit(s)	Dimensions	Link weight	Material, link	Material, pivot
XTTP 5	XTTL 35	5056659		12 g	POM B	See page III
XTTP 5 EC	5053718	5056660		12 g	POM A COND	PA66 ISD

Flat top friction chain

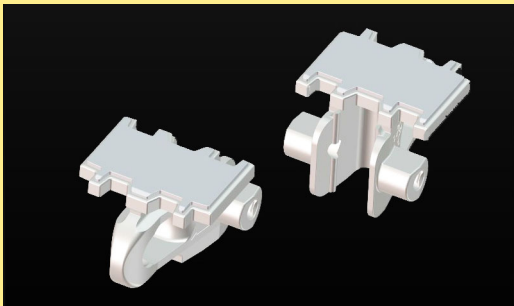
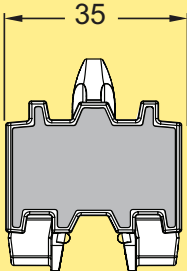
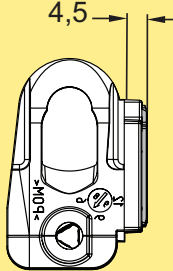
						
Chain	Link(s)	Link kit(s)	Dimensions	Link weight	Material, link	Material, pivot
XTTP 5 FA	FLX1002768	FLX1002865		12 g	POM B	See page III

