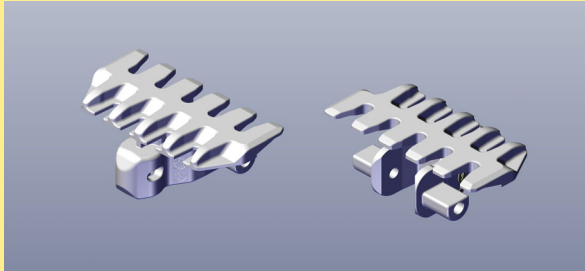
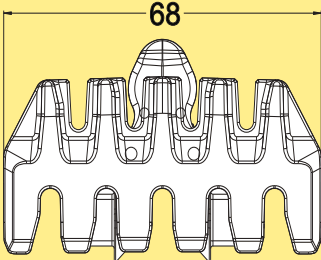
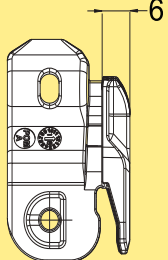

# Conveyor system X70X – links and chains

Each link kit contains 10 links, 10 plastic pivots, and 10 stainless steel pins, unless otherwise specified. Material abbreviations: See page III.

## Plain chain

|   |                |  |                   |   |                       |                        |
|---|----------------|--|-------------------|---|-----------------------|------------------------|
|  |                |  |                   |  |                       |                        |
| <b>Chain</b>  | <b>Link(s)</b> | <b>Link kit(s)</b>   | <b>Dimensions</b> | <b>Link weight</b>  | <b>Material, link</b> | <b>Material, pivot</b> |
| XLTPX 5A70 K  | FLX1002293     | FLX1001236   |                   |   | POM A                 | See page III           |

## Flat top friction chain

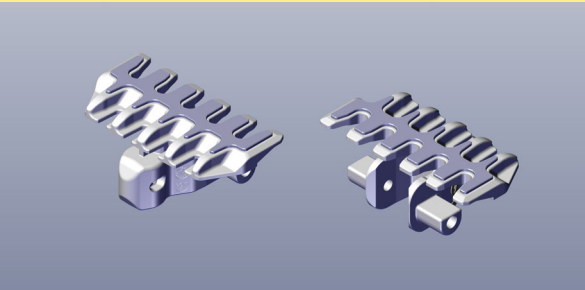
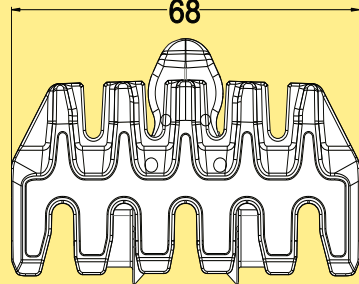
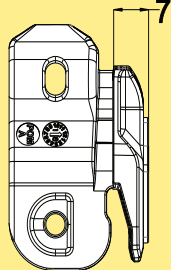
|   |                |   |                   |  |                       |                        |
|---|----------------|---|-------------------|--|-----------------------|------------------------|
|                                   |                |  |                   |  |                       |                        |
| Friction insert is polyether-polyamide. Slope <math><30^\circ</math>. Light goods: blister packs, small boxes, etc. |                |   |                   |  |                       |                        |
| <b>Chain</b>  | <b>Link(s)</b> | <b>Link kit(s)</b>  | <b>Dimensions</b> | <b>Link weight</b>   | <b>Material, link</b> | <b>Material, pivot</b> |
| XLTPX 5A70 KF   | FLX1000902     | FLX1001237  |                   |  | POM A                 | See page III           |

