

Product overview

Contents

Stainless steel conveyor systems.....	7	Technical data – conveyors	11
Conveyor accessories	8	Chains – configuration strings	15
Conveyor comparison chart	8	General safety and design considerations	17
Conveyor component overview	9	Maintenance	19

Stainless steel conveyor systems

Stainless steel conveyor system X70X, X85X, X180X, X300X (68, 83, 175, 295 mm chain)

Features

Split beams in stainless steel for easy cleaning. High resistance to aggressive chemicals. Matching drive units, idlers and guide rail and support components. Standard X180/X300 chains.

Series X are stainless steel designs adapted to the requirements of the food processing, pharmaceutical and hygiene industries. The Series X system is designed for easy integration with aluminium systems.

Examples of application areas

Aerosol cans, liquid soap in plastic bags, soft cheese, detergent powder, tissue paper rolls, food products, personal care products.

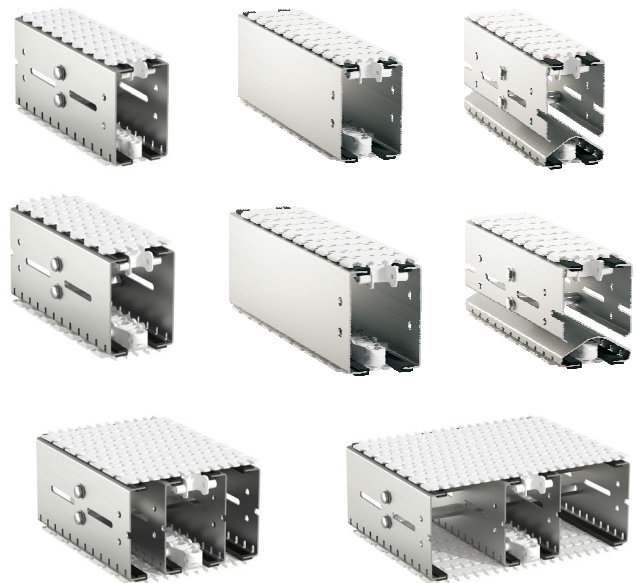

- PO
- X70X
- X85X
- X180X
- X300X

Stainless steel conveyor system WL222X, WL273X, WL374X, WL526X, WL678X (152/203/304/456/608 mm belt)

Features

FlexLink's newly developed stainless steel conveyor is designed to fit into demanding primary and secondary packaging applications. It addresses important aspects of today's packing processes, such as being easy to clean, smooth handling of products, safe for operators, robust design, long life, and easy to maintain with a low cost of ownership. The modularized and standardized design ensures fast set up, and facilitates rapid future extensions and changes.

Examples of application areas

Dry product handling such as bread or frozen products in primary packaging where there is a chance that the package could rupture should also be considered - the conveyor would be an easy to clean alternative to traditional conveyors.

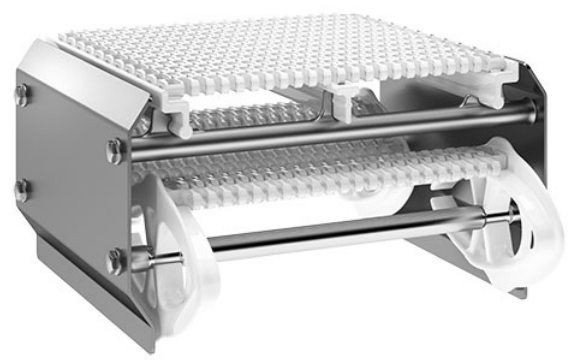

- WL 222X
- WL 273X
- WL 374X
- WL 526X
- WL 678X
- CSX
- GRX
- FSTX
- TR
- APX
- IDX

Conveyor accessories

Guide rail components (GRX)

Catalogue section *Guide rail components* deals with various types of guide rails and guide rail support components. Those products are used with several of the conveyor systems. A number of pre-designed guide rail structures are shown as examples. New components are available for building automatically adjustable guide rail systems, accommodating products with different widths.

Conveyor support components (CSX)

The conveyors are held in place by a well balanced range of support components, with beam support brackets, support beams, feet, etc.

A number of pre-designed support structures are shown as examples.

Conveyor structures built from aluminium beams with standardized T-slots simplify attachment of components and accessories.

Conveyor comparison chart

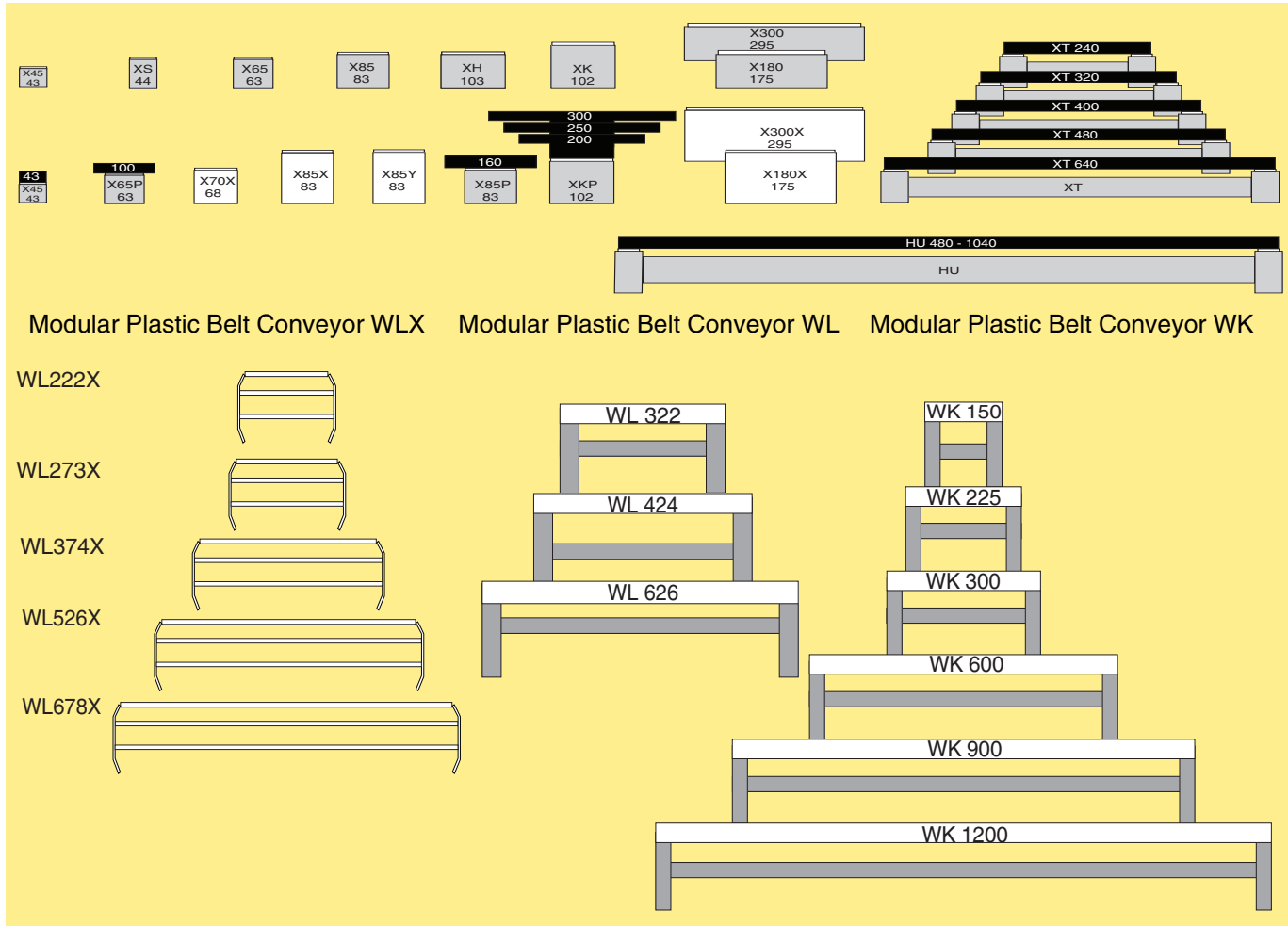

Simplified end views of conveyor beams, drawn to the same relative scale. Numeric values are widths in mm.

Legend

- Light grey: Conveyor beams
- Dark grey: Pallets or puck
- White: Chain/Belt
- X70X, X85X, X180X, X300X: Stainless steel conveyor
- WL222X, WL273X, WL374X, WL526X, WL678X

Conveyor component overview

Stainless steel conveyor system X70X, X85X, X180X, X300X – Chains

Plain chain

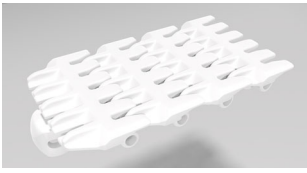

Friction top chain

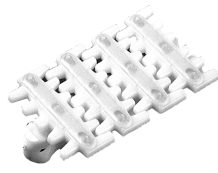

Stainless steel conveyor system X70X, X85X, X180X, X300X – beams and beam support brackets

Conveyor beam

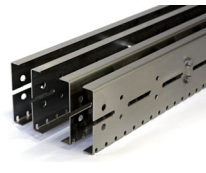

Beam support bracket



Stainless steel conveyor system X70X, X85X, X180X, X300X – drive units and idlers

End drive units



Idler end unit



Stainless steel conveyor system X70X, X85X, X180X, X300X – guide rail system

Guide rail profiles



Guide rail brackets



Stainless steel conveyor system X70X, X85X, X180X, X300X – bends

Wheel bends



Plain bends

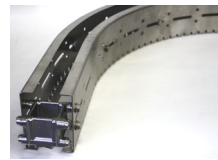

Vertical bends

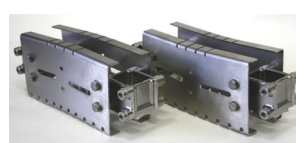

Stainless steel conveyor system X70X, X85X, X180X, X300X – support

Support components



PO

X70X

X85X

X180X

X300X

WL
222X

WL
273X

WL
374X

WL
526X

WL
678X

CSX

GRX

FSTX

TR

APX

IDX

Stainless steel conveyor system WL222X, WL273X, WL374X, WL526X, WL678X – Belts

Radius flush grid belt, Dry



Flat top belt



Stainless steel conveyor system WL222X, WL273X, WL374X, WL526X, WL678X – beams and beam support brackets

Conveyor beam



Beam support bracket



Stainless steel conveyor system WL222X, WL273X, WL374X, WL526X, WL678X – drive units and idlers

End drive units Idler end unit



Stainless steel conveyor system WL222X, WL273X, WL374X, WL526X, WL678X – bends

Stainless steel conveyor system WL222X, WL273X, WL374X, WL526X, WL678X– support

Plain bends

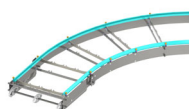

Vertical bends

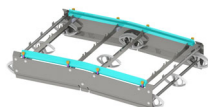

Support components



Drive unit capacity

The required motor output power P depends on

- Traction force F
- Chain speed v

The following equation applies:

$$P [W] = 1/60 \times F [N] \times v [m/min]$$

The maximum permissible traction force of the various drive units, and other useful parameters, are shown in the following tables. Also see diagrams on page 12.

More information

Detailed information about the drive units can be found in “Drive unit guide” and “Spare parts”. See “Technical library” on FlexLink’s website. For information about drive units with variable speed motors, see *Drive Unit Guide*.

Drive unit specifications

End drive unit

	X70X	X85X	X180X/ X300X	WLX
Number of teeth on sprocket wheel	H: 16	H: 12	12	2x16
Chain pitch (mm)	25,4	33,5	33,5	25,4
Maximum traction force (N)				See chapter WLX
Type H_P, HN_P Standard	800	1250	1250	

Temperatures

What temperatures can a FlexLink’s conveyor operate in?

A FlexLink conveyor can operate in temperatures between $-20\text{ }^{\circ}\text{C}$ and $+60\text{ }^{\circ}\text{C}$.

Temperatures up to $+100\text{ }^{\circ}\text{C}$ can be taken for short periods. This is mainly for cleaning and rinsing.

What happens if these limits exceed?

In cases where the recommended specifications have not been followed, such as in very warm and cold conditions, this will change the properties of the materials used.

FlexLink cannot guarantee components and their functionality in case these recommendations are not followed.

PO

X70X

X85X

X180X

X300X

WL
222X

WL
273X

WL
374X

WL
526X

WL
678X

CSX

GRX

FSTX

TR

APX

IDX

Chain tension limits

To determine the maximum chain tension allowed, it is necessary to take conveyor speed and conveyor length into consideration. Check diagram 1A and 2B-2E and use the lowest tension value obtained.

Note

The drive unit configurator on the web always proposes a motor strong enough to utilize the maximum permissible chain tension as specified in the diagrams below. Variable speed motors at very low frequencies can sometimes drop below the specified tension. Always check motor data if high pulling force is critical.

Maximum permissible chain tension

Diagram 1A

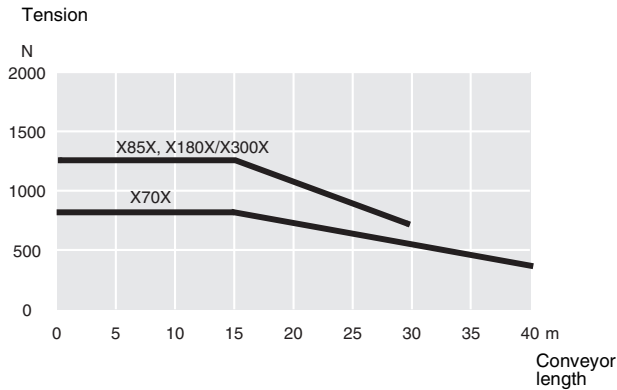

Tension/length diagram, X70X, X85X, X180X, X300X

Diagram 2A

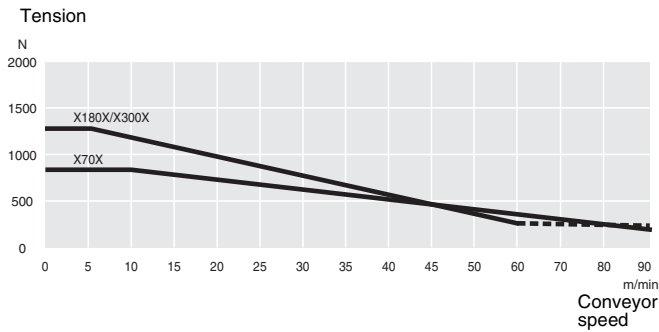

Tension/speed diagram, X70X, X180X/X300X conveyors

Diagram 2B

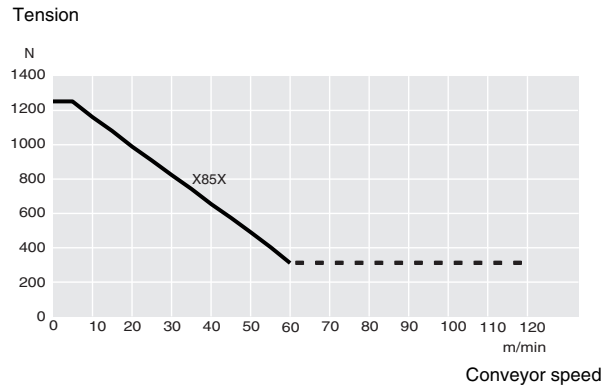

Tension/speed diagram, X85X

Selecting the right chain material

Links

The base link parts of the chain links have the same basic shape, and the same technical properties. Five different materials are used. The standard material is acetal resin (POM). Different materials are used.

- POM A: Copolymer Acetal with silicon
- POM B: Homopolymer Acetal, silicon free
- POM C: Copolymer Acetal, silicon free
- POM D: Homopolymer with ultra low wear additive

Properties	Copolymer POM A / C	Homopolymer POM B / D
Heat ageing	(+) Superior	0
Hot water resistance	(+) Superior	(-)
Chemical resistance	(+) Superior ph 4-14	(-) ph 4-10
Tensile strength	0	(+) Superior
Stiffness	0	(+) Superior
Impact Strength	0	(+) Superior

Strength values at 20 °C:

Product (POM)	X45	XS	X70X	X65	X85, XH, X180/X300	XK	XT, X45H	XT Compact
Maximum working tension [N]	200	500	800	1000	1250	2500	900	180

The other materials are not as strong as POM:

- Polyester (PBT): 50% of POM value
- Polyvinylidene fluoride (PVDF): 40% of POM value.
- Conductive POM: 40% of POM value
- High temperature resistant material, 50% of POM value
- Intrinsically static dissipative (ISD) POM: see the following table..

Product (POM ISD)	X65	X85	XH	XT X45H	XT Compact
Maximum working tension	400 N	400 N	550 N	450 N	180 N

Pivots

Most pivots are made in materials as specified in the table below. Otherwise the material is specified next to the link designation.

Link	POM	POM (ISD)	PBT	PVDF
Pivot	PA66	PA66 (ISD)	PA66	PVDF

Chain pitch and weight

The *Chain guide* lists the weight of most links. To calculate chain weight, you need to know the chain pitch (see picture below), the weight of the plastic pivot, the weight of the steel pin, and the cleat separation. See the following table.

Parameter	Conveyor type		
	X70X	X85X	X180X/X300X
Chain pitch, mm	25,4	33,5	33,5
Plastic pivot weight, g	1	2	2
Steel pin weight, g	4	10	10

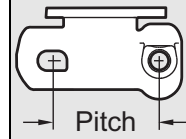

Note

Some of the chains require modification of the drive units. There may also be limitations on minimum bend radius.

Material abbreviations

Material abbreviation	Material
POM*	Acetal resin
POM* polished	Acetal resin, polished surface
POM*, pivot PVDF	Acetal resin, pivot: PVDF
POM* GY	Acetal resin, grey
POM* BK	Acetal resin, black
POM* COND	Acetal resin, conductive
POM* ISD NAT	Acetal resin ISD, natural colour
POM* ISD GY	Acetal resin ISD, grey
PBT	Polyester
PVDF	Polyvinylidene fluoride
PVDF, pivot PA66	Polyvinylidene fluoride, pivot: PA66
POM* + steel	Acetal resin, steel top
POM* + SS	Acetal resin, stainless steel top
PA	Polyamide

Chain strength and expansion vs. temperature

Temperature °C	-20	0	20	40	60	80	100	120
Tensile strength factor	1,2	1,1	1,0	0,9	0,8	0,6	0,5	0,3
Linear expansion%	-0,4	-0,2	0	0,2	0,5	0,8	1,0	1,3

Service factor

The maximum permissible chain tension (see diagrams 1A and 2A-2E on Page 12) depends on the number of conveyor starts and stops per hour. Many conveyors run continuously, whereas others start and stop frequently. It is obvious that frequent starts and stops increase the stress on the chain.

The service factor (see table below) is used to derate for high frequency of starts and stops and for high chain speeds. Divide the tension limit obtained from the graphs by the service factor to get the derated tension limit. A high service factor can be reduced by providing a soft start/stop function.

Operating conditions	Service factor
Low to moderate speed or max. 1 start/stop per hour	1,0
Max. 10 starts/stops per hour	1,2
Max. 30 starts/stops per hour	1,4
High speed, heavy load, or more than 30 starts/stops per hour	1,6

Important

The chain tension calculations are made to ensure that the capacity of the drive unit is sufficient, but not excessive, in relation to the strength and friction of the chain. The calculations do not take into account the increased wear resulting from the higher friction in plain bends.

Chain tension calculations

Chain tension

The tension building up in the chain can be divided into several components:

- 1 Friction between unloaded chain and slide rails, for example on the underside of the conveyor beam.
- 2 Friction between loaded chain and slide rails (Figure A).

Figure A

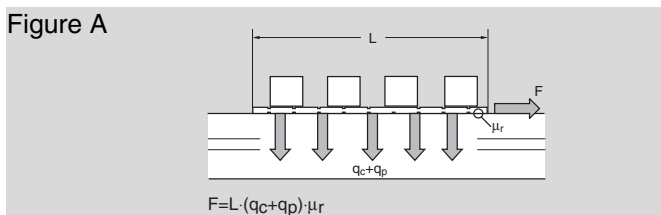

- 3 Friction between accumulating products and top surface of chain (Figure B).

Figure B

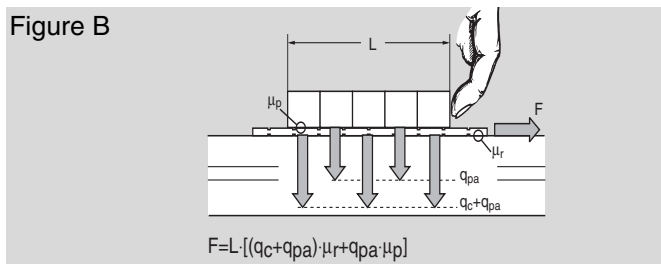

- 4 Gravity force acting on products and chain in inclines and verticals (Figure C).

Figure C

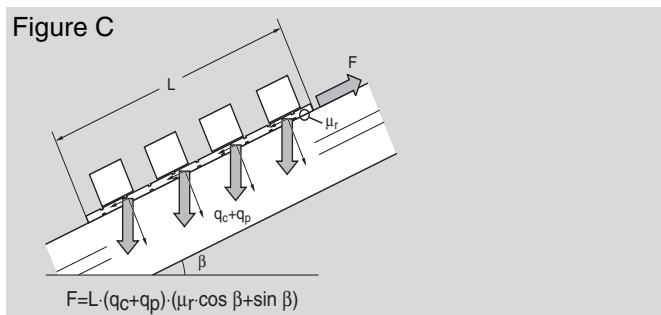

- 5 Added friction in plain bends. This friction is proportional to the chain tension on the low-tension side of the bend. This means that the actual friction depends on the position of the bend in the conveyor (Figure D).

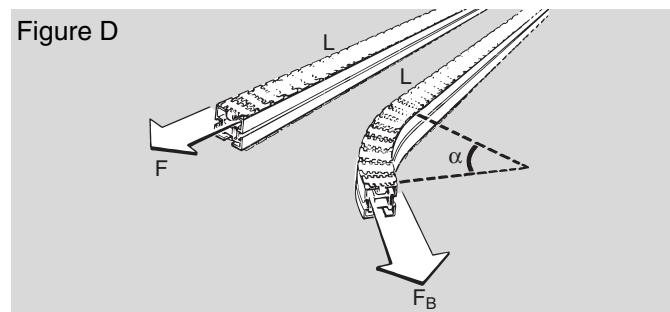

Traction force

The traction force F required to move the chain depends on the following factors:

Conveyor length.....	L
Product gravity load per m Transport.....	q_p
Accumulation	q_{pa}
Chain gravity load per m	q_c
Friction coefficient	
Between chain and slide rail	μ_r
Between chain and products.....	μ_p
Bend factor, α° plain bend (hor./vert.).....	$k\alpha$
Inclination angle	β

Chains – configuration strings

Below, example of text strings obtained from the configurator with explanations.

Input

Platform: “X85”

Chain type: “XBTF 5A85 U”

CC distance (mm) [133..167]: “167” (depending on the PAR value, the CC distance will change.)

PAR 1-20: “5” (depending on the CC distance, the PAR value will change.)

Total desired length (m): “26”

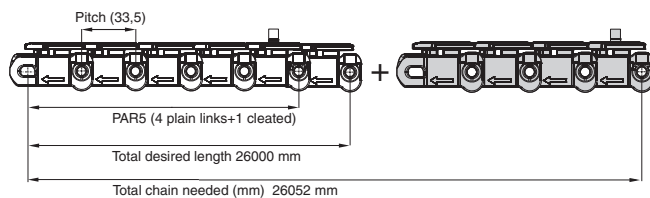
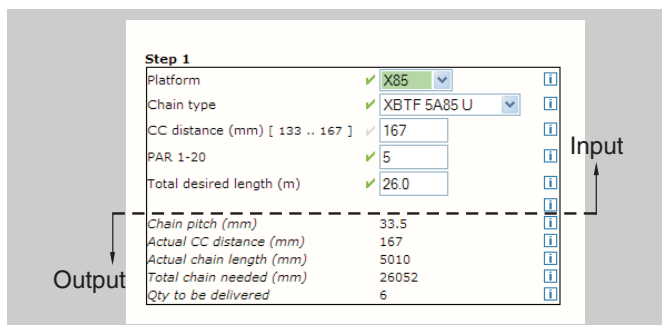

Qty to be delivered: “6” (The desired length is 26 m and items will be delivered in multiples of 5 -meter lengths; to cover demand of necessary length, 6 packages of chains are needed.)

Configuration result:

Item no	Qty	Description
XBTF 5A85 U	6	XBTF 5A85 U PAR5

Output

Chain pitch: “33,5” (see table below)

Parameter	Conveyor type				
	X70X, XS, X45H, X65, XT	X85	XH	XK	X180/X300
Chain pitch, mm	25,4	33,5	35,5	38,1	33,5

The diagram shows a chain link with a pitch measurement of 33.5 mm.

Actual CC distance (mm): The selected CC distance will be round off to the closest value which matches the chain pitch.

E.g. for value 400, PlatformX85 (pitch 33,5 mm), CC distance= 400 mm, the Actual CC will be 402 mm.

Actual chain length (mm): The actual length depending on the CC/PAR value and that the chain always ends with a cleated link. This causes the length to vary from 3000-3250 mm or 5000 to 5500 mm depending on selected platform.

Total chain needed (mm): “26 052” (All configurable chains starts with a number of plain links in this case 4 links before the cleat link (PAR5). The desired length is 26 000 mm and the chain pitch for X85 is 33,5 mm. This creates an incorrect number of plain links before the last cleat link. The length is corrected by adding plain links (according to the desired PAR value) and a cleated link after the “last” cleat link. See picture.

PO
X70X
X85X
X180X
X300X
WL
222X
WL
273X
WL
374X
WL
526X
WL
678X
CSX
GRX
FSTX
TR
APX
IDX

Bend factors

Each plain bend introduces a bend factor $k\alpha$. This factor is defined as the ratio between chain tension measured just after the bend and that measured before the bend. The bend factor depends on

- the amount of direction change of the bend (angle α)
- the coefficient of friction, μ_r , for the friction between chain and slide rails.

When the conveyor is dry and clean, the friction coefficient, μ_r , will be close to 0,1.

The bend factor must be used since the frictional force of a plain bend depends not only on the chain and product weight and the coefficient of friction, but also on the actual tension of the chain through the bend. This tension causes additional pressure to the conveyor beam and slide rail from the chain. The additional force is directed towards the centre of the bend.

Calculation of this additional force is more complicated, since the chain tension varies through the conveyor, being maximum at the “pull” side of the drive unit, and virtually zero at the inlet of the return chain. The bend factor provides a means of including the added friction in bends into the calculations.

The same bend factors apply to horizontal and vertical plain bends. See the table.

Note

Plain bends should only be used in exceptional cases. For normal applications, use wheel bends.

Bend type (Vertical or Plain bend)	30°	45°	60°	90°
Bend factor $k\alpha$	1,2	1,3	1,4	1,6

Introduction

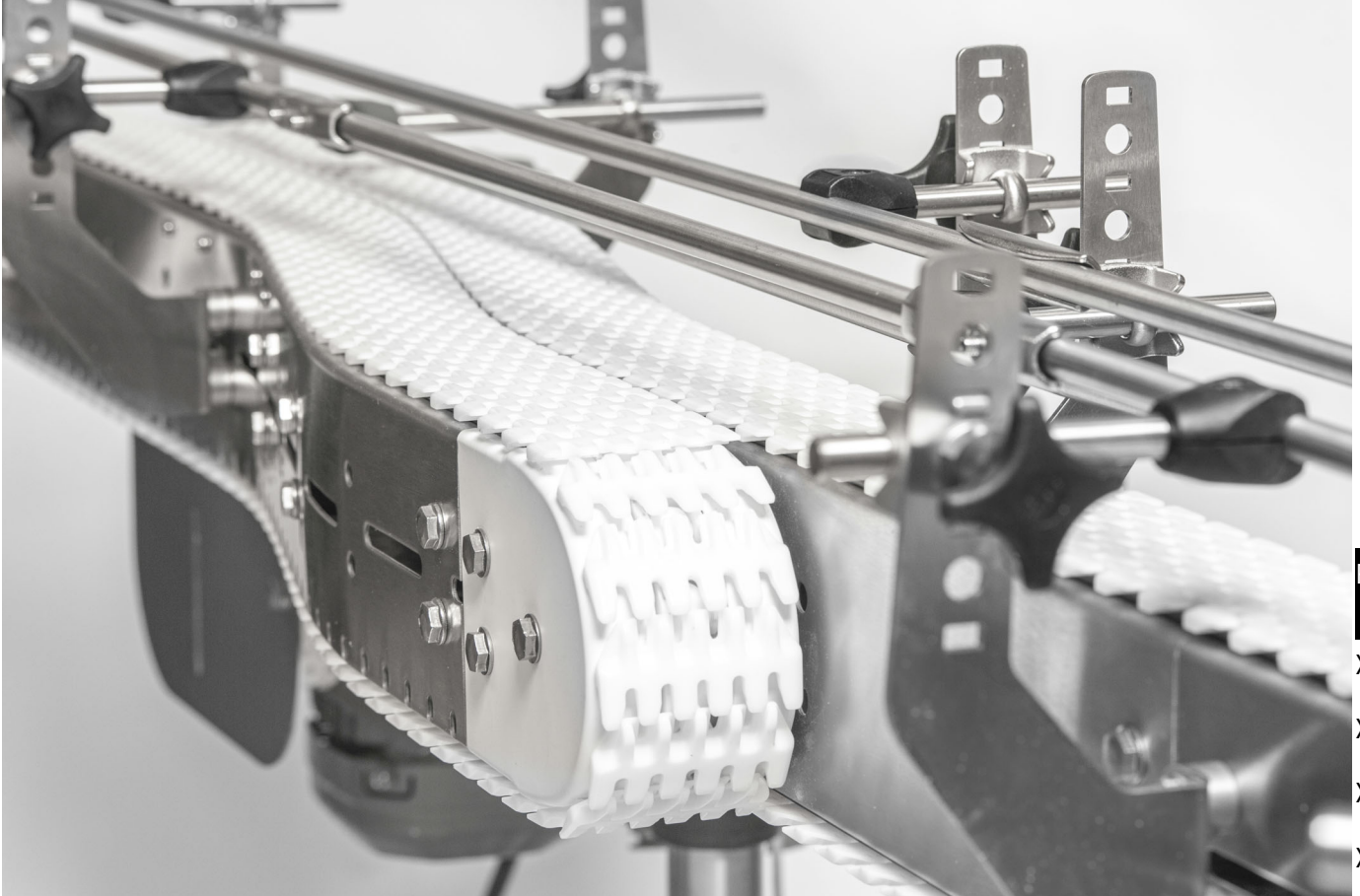

PO

X70X

X85X

X180X

X300X

WL
222X

WL
273X

WL
374X

WL
526X

WL
678X

CSX

GRX

FSTX

TR

APX

IDX

Critical factor

To achieve an operational installation which is reasonably safe for all people involved in its use and maintenance, it is necessary to consider certain aspects. This is done when designing a conveyor system. The chain is generally the critical factor to consider with guarding.

Safeguarding

All pinch and shear points as well as other exposed moving parts that present a hazard to people at their workstations or their passageways must be safeguarded. Overhead conveyors must be guarded to prevent objects falling. Cleated conveyor chains are more hazardous in creating more pinch and shear points than plain conveyor chains.

Safeguarding can be achieved by:

- Location
Location of the hazardous area away from the area occupied by personnel, wherever possible.
- Guards
Mechanical barriers preventing entry into the hazardous areas or protecting against falling objects.

- Control devices
Machine controls which prevent the interruption of hazardous operations/conditions.
- Warnings
Instructions, warning labels, or sound/light signals which alert to hazardous conditions.

Safeguarding should be designed to minimize discomfort or difficulties to the operator. Bypassing or overriding the safeguarding during operation should be difficult.

Warning labels etc. should only be used when all other means of safeguarding will impair the function of the installation or are not cost effective.

The degree of safeguarding required should be identified during the implementation of the essential safety requirement during the design process.

Special considerations

When correctly applied, FlexLink family of components are safe to use and maintain. It is however necessary for those responsible for design, installation, operation and maintenance of installations to be aware of certain areas where special attention is required.

Note

The slip clutch is not a personnel safety device, but a device to protect the conveyor equipment.

End drive units

- The chain slack (catenary) of the end drive units must be maintained during the system lifetime.
- If side plates are fitted, the chain must be shortened if the chain becomes visible below the level of the side plates.
- The opening between the links when they turn round the end roller could be a risk. Drive ends should not be accessible during conveyor operation wherever possible.

For coupled drive units, safety protection should be applied to the connecting shaft.

Idler units

- The opening between the links when they turn round the idler roller could be a risk. Idler ends should not be accessible during conveyor operation wherever possible.

Wheel bends

- Guarding may be required at wheel bends depending upon location of bends and load applied to the conveyor.

Cleated chains

- Any application incorporating cleated chains requires careful safety consideration. Pinch and shear points are generated throughout the assembly of the incorporated components. Therefore generous guarding should always be employed to fully protect within user operating limitations.
- There is a higher risk of product damage when using cleated chains. Special attention must be given to operator access in the event of products becoming trapped or similar.

Maintenance

The maintenance routine of FlexLink's conveyors should also include procedures to ensure that the guarding remains securely fastened and effective (if not interlocked via control system etc.).

FlexLink's components are continuously reviewed to improve performance either by design modification or material upgrade. In all these reviews user safety is our primary consideration.

All associated technical data are retained at the manufacturer's address.

Control system

Before operating or completing any maintenance on control system, read the associated section as supplied with the equipment documentation.

If there are any questions as to the safe operating procedures of the equipment supplied, please contact FlexLink immediately.

System maintenance

Introduction

The following section is designed to offer assistance for your planned maintenance schedule. It may become evident that the suggested maintenance intervals can be extended to accommodate your local environmental conditions.

Maintenance of the conveyor systems should only be carried out by competent persons, who are familiar with FlexLink's equipment. If there is any doubt as to the most suitable procedure for maintenance, consult your FlexLink supplier.

Run-in period

Two to three weeks are usually enough as a run-in period. During this time, the conveyor should be cleaned a couple of times, to remove dust. After run-in, wear will be minimal, unless particles from the product or process reach the conveyor continuously.

Chain elongation

Especially during the run-in period, and if the load is heavy, the conveyor chain will slowly increase in length. This effect will be most obvious for long conveyors. After continuous operation for two weeks, it is often possible to remove a couple of chain links. After this period, we recommend a check every 3–6 months.

Non FlexLink equipment

Equipment and components which are not from the FlexLink family of products should be maintained and serviced in accordance with their respective manufacturer's instructions.

Safety considerations

Before starting any maintenance on your FlexLink equipment, the following safety instructions must be observed:

- All electricity must be switched off.
- Make sure that the motor switch is also switched off and locked in the "off" position.
- Pneumatic and/or hydraulic power must be disconnected and any pressure accumulation released.
- Products being transported should, if possible, be removed from the conveyor chain.
- Staff affected must be informed that maintenance work is being undertaken.

Warning

Do not climb onto the equipment.

PO

X70X

X85X

X180X

X300X

WL
222X

WL
273X

WL
374X

WL
526X

WL
678X

CSX

GRX

FSTX

TR

APX

IDX

