

# RC12 Collaborative Palletizer



## Introducing the RC12 standardized collaborative palletizer

The new RC12 has been designed and standardized to be faster, safer, and easier to use than ever before. With the latest upgrades, this palletizing cell is ready to meet all global standards while providing unparalleled efficiency in production or logistics operations.

## Revolutionized palletizing with the latest technology

FlexLink's collaborative palletizing cells do not require a fence system, cage, or other safety elements and allows operators to work safely side-by-side with the robot. The use of collaborative robots reduces the footprint significantly compared to industrial robots. The RC12 is quick to move, install, and easy to configure.

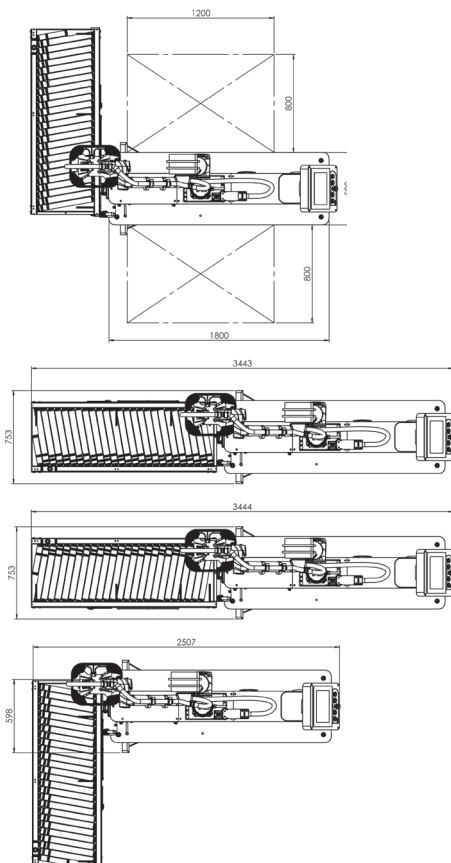

## Key features

### Standardized and open for customization

The reliability of a standardized product with the flexibility of a customized application layer.

### Latest robot arm: Omron TM12-S

The RC12 is equipped with Omron's TM12-S, the latest collaborative robot arm technology that ensures efficient and seamless operations.

### New base design

The RC12 complies with the machinery and robotics regulations (ISO/TS 15066) for improved safety. The standard unit will be delivered with CE certification and is UL compliant. Its enlarged electrical cabinet allows easy customization, access, and maintenance.

### Optimized gripper and safety paddings

The updated gripper and safety paddings reduce the risk of injury, making the RC12 the safest cobot palletizer available on the market.

### Intuitive interface and software

The intuitive interface and Robot Config palletizing software guides users in creating pallet patterns without programming skills, enabling production start in minutes.

## Benefits

- **Standardized and open for customization:** The standardized base is designed for easy customization, allowing the RC12 to be adapted to specific project requirements with minimal effort.
- **Unmatched safety keeping high throughput:** The RC12 is the safest collaborative palletizer available on the market, with advanced safety mechanisms to protect operators, keeping high throughput even when the operator is close by.
- **Ease-of-use:** The intuitive software and user-friendly interface make it easy to operate, reducing the learning curve and minimizing downtime.



## Robot Config

The RC12 features an intuitive, user-friendly interface, allowing seamless operations. With the Robot Config palletizing software integrated directly into the HMI, configuring new SKUs is quick and efficient. In just 5 minutes, users can set up a new pallet pattern and resume production, maximizing line efficiency and minimizing downtime.

## Standard features

- Robot Arm: Omron TM12-S
- In-feed conveyor: Height adjustable support legs: 700, 744, 774, 818 and 862 mm
- In-feed conveyor positions: 4 positions available (center right, center left, left, right)
- Power supply: 110/230 VAC, single-phase
- Vacuum system: Integrated vacuum pump, or venturi on request
- Footprint: Less than 10 m<sup>2</sup>
- Palletizing capacity: Up to 8 (or 14 with double pick) parts per minute (PPM)
- Max box weight: Up to 10 kg
- Min box size: From 150 × 150 × 100 mm
- Max box size: Up to 600 × 400 × 500 mm
- Pallet height: Up to 2040 mm
- Control system: Omron or Allen Bradley PLC
- Conveyor: 2 zones, 1512 mm

## Options

- Gripper: Single-pick or double-pick, safety enhanced
- 500 mm electrical pedestal or 800 mm
- Palletizing and depalletizing modes
- Maintenance and emergency kits
- Remote assistance
- Docking station

## Customization examples

- Safety scanners, fences
- Custom gripper
- Reject stations
- QR/bar codes reading
- Rigid or flexible interlayers magazine, etc.

## Certification

- Certification: CE certified, UL compliant