

PRE-REQUISITES

Recommended tools

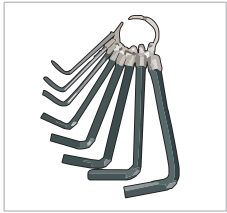

SAFETY



WARNING
The system must not be operated without safety equipment properly mounted.



WARNING
At installation, maintenance and service, make sure the motor is shut off.



WARNING
Pinch Point



CAUTION
Due to heavy weight - 2 person lift, or mechanical lift equipment.

PRODUCTS

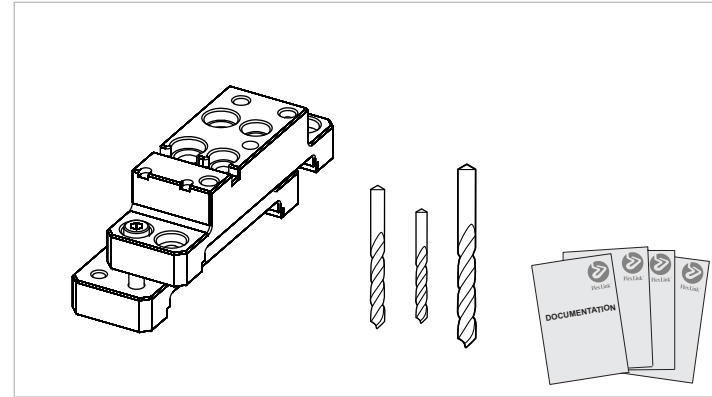

Drilling

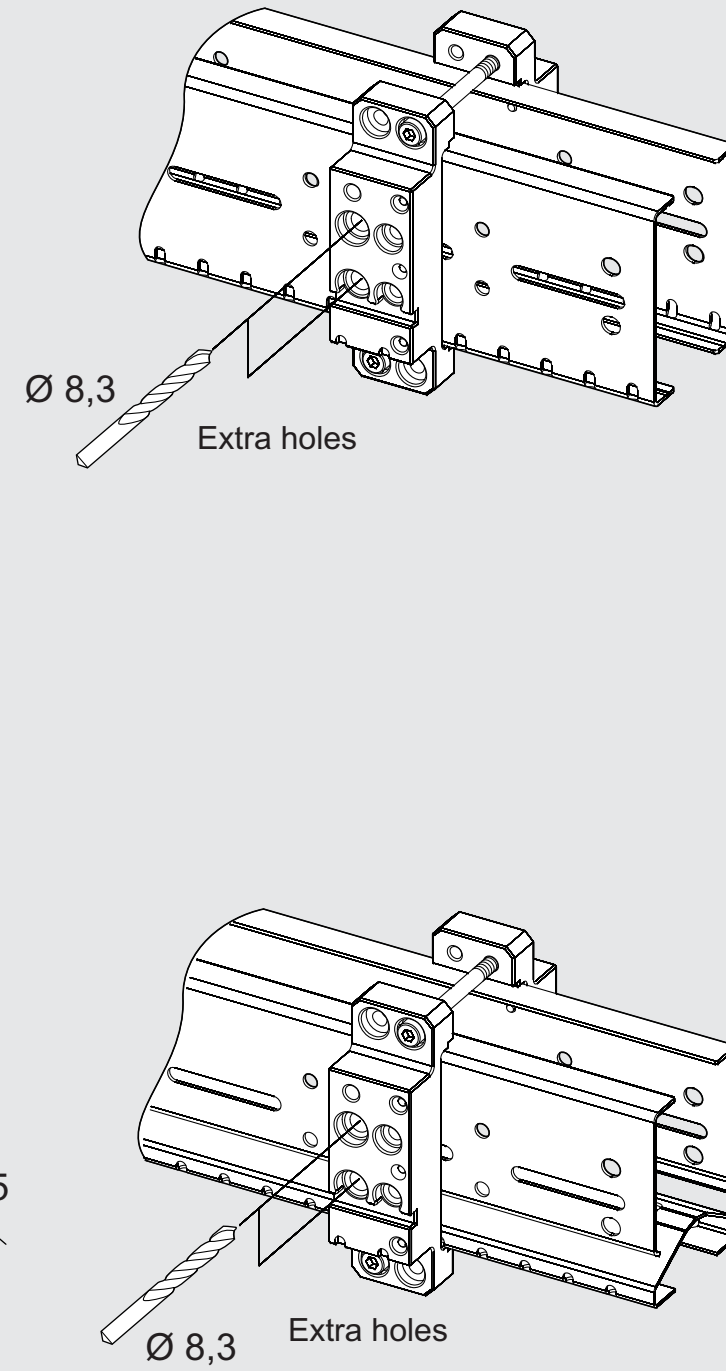
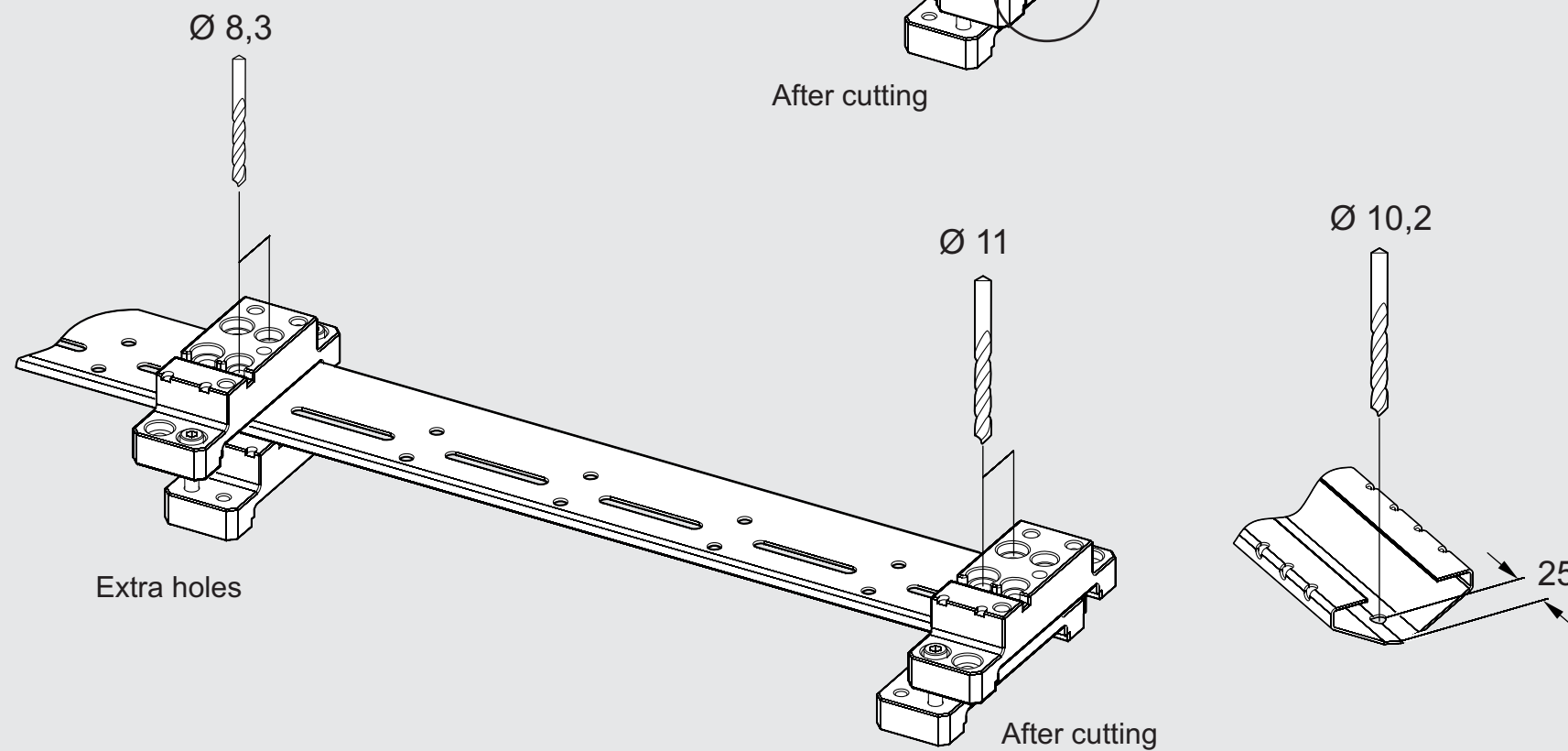
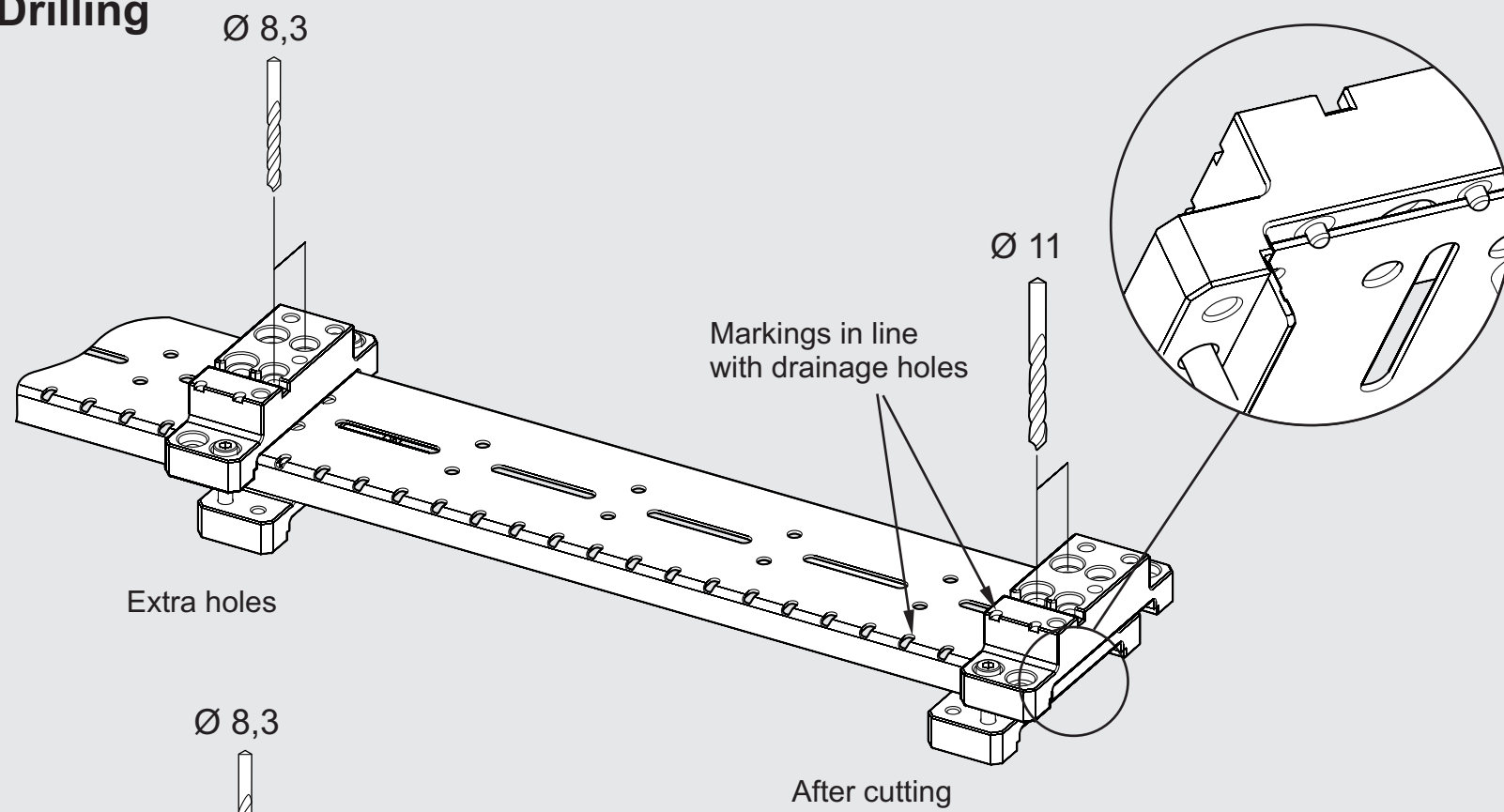

Example, drilling equipment

Cutting



Clean carefully

Type X



This side up
Cut with moderate feeding speed
and gentle pressure

Type Y



Do not tighten too hard

Type Y



This side up

ASSEMBLY INSTRUCTION

Drill fixture
5114621

