

Modular belt conveyor WL678X

Contents

System information.....	153	End Drive Units - Introduction.....	162
Conveyor sections.....	154	Drive units – configuration strings.....	163
Modular Belts - Introduction.....	155	End drive units.....	164
Modular belts.....	156	Idler end units – Introduction.....	166
Conveyor Beams - Introduction.....	158	Idler units.....	166
Conveyor frame components.....	160	Plain Bends - Introduction.....	167
Slide rail.....	161	Support System Modules - Introduction.....	169

System information



PO
X70X
X85X
X180X
X300X

WL
222X

WL
273X

WL
374X

WL
526X

WL
678X

CSX

GRX

FSTX

TR

APX

IDX

System overview

FlexLink's newly developed stainless steel conveyor is designed to fit into demanding primary and secondary packaging applications. It addresses important aspects of today's packing processes, such as being easy to clean, smooth handling of products, safe for operators, robust design, long life, and easy to maintain with a low cost of ownership.

The modularized and standardized design ensures fast set up, and facilitates rapid future extensions and changes.

Technical specifications

Maximum speed:	40 m/min
Maximum conveyor length:	20 m
Max single item weight:	up to 30 kg
Total load on a conveyor:	300 kg
Max product weight per belt pitch:	1,5 kg/slide rail
Max permissible pull force (with bends):	1000 N
Max permissible pull force (without bends):	1200 N

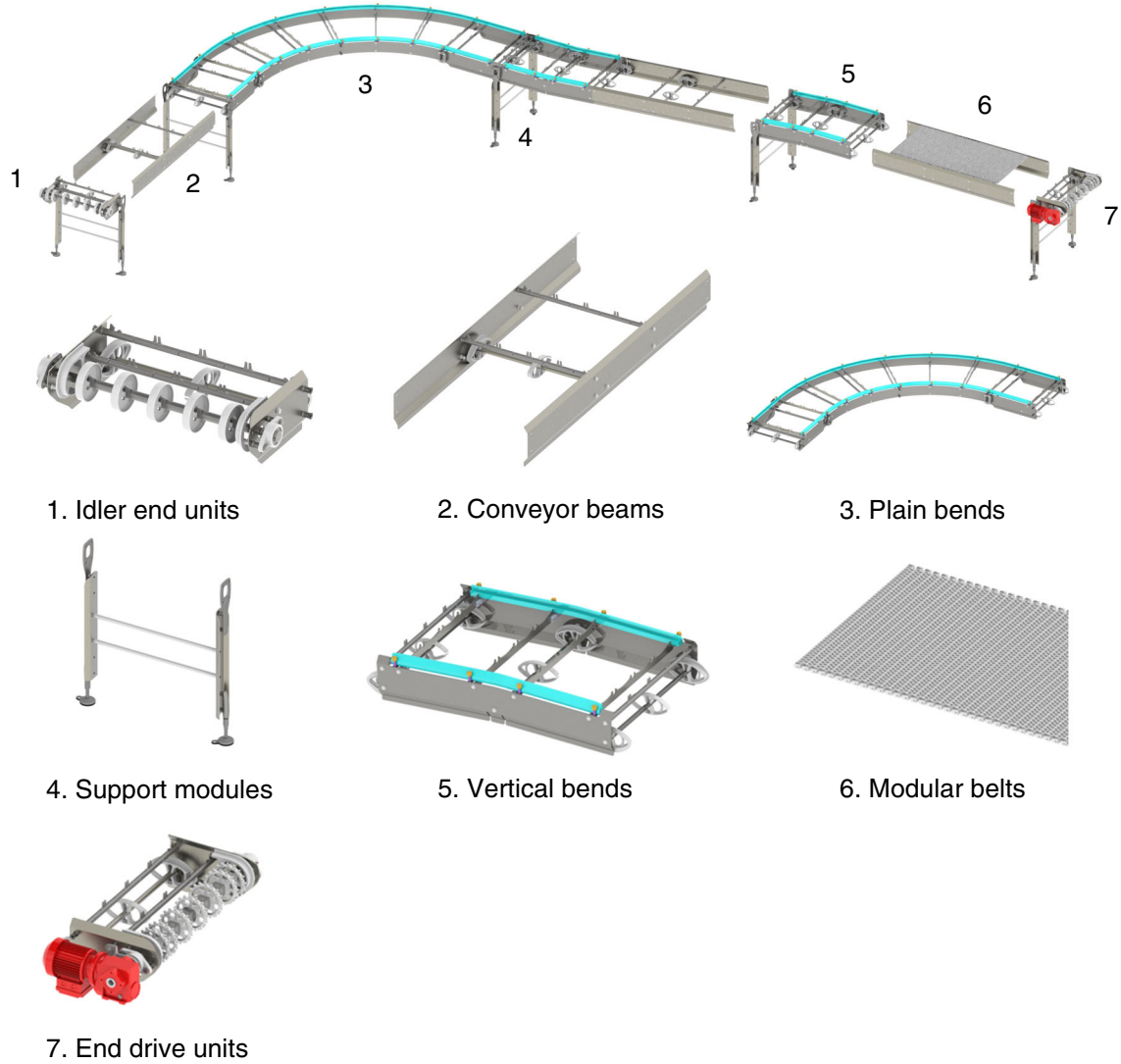

The modular plastic belt conveyor in five widths – 222, 273, 374, 526 and 678 mm – can be built as straight sections or in S, U or L-shape with 30, 45, 60, 90° (180° only for 222 and 273) horizontal bend, or combinations thereof. Vertical bends are available in 5° (3° only for 222 and 273) positive or negative.

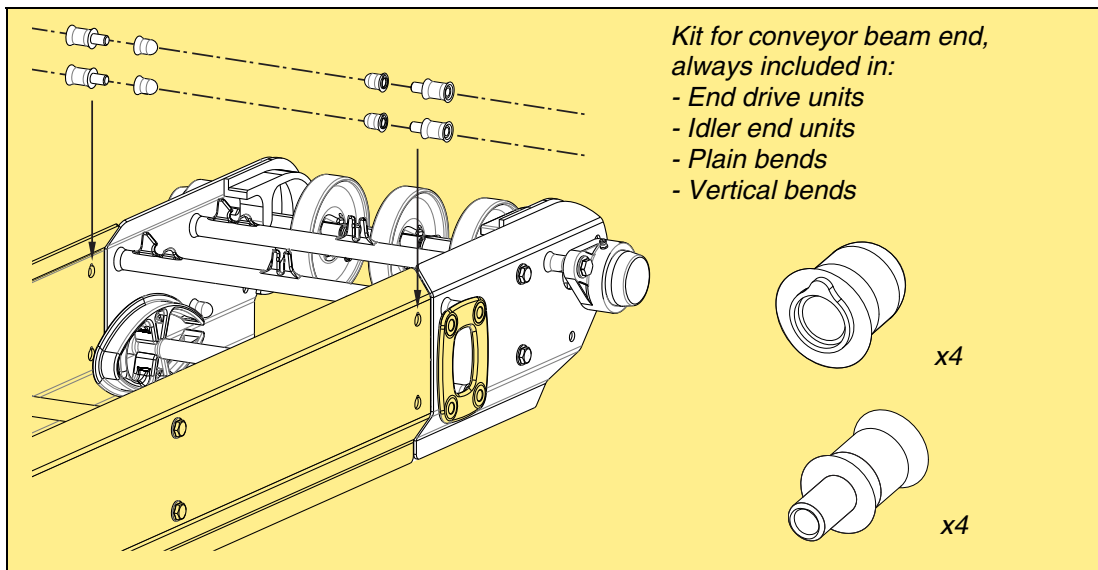

Modular Belts - Introduction



Modular belt, Radius flush grid, curve-running

The belt consists of plastic hinged links connected by plastic rods. The wide belts are woven together by links that are 102 mm, 124 mm, and 180 mm wide. The assembled belt forms a wide, flat, and tight conveyor surface. Five standard widths of belt can be delivered: 152 mm, 203 mm, 304 mm, 456 mm, and 608 mm.

Standard belt color is white but blue belts can also be ordered.

Belts with polyamide pins are available for dry or semi-wet applications. In constant wet applications, belts with acetal pins must be used. This is due to the fact that polyamide pins will absorb water and swell in wet applications, and acetal pins will squeak in dry environments.

Flat top belt, straight running

The belt has a minimal number of seams and has open hinges that are easy to clean. The belt is white and is available with acetal pins for wet applications

Travel direction of the belts:

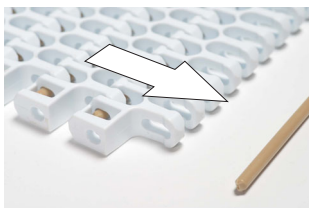

Radius flush grid

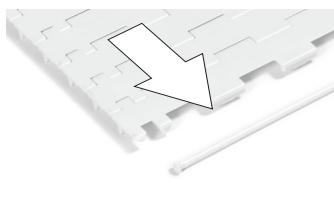

Flat top belt

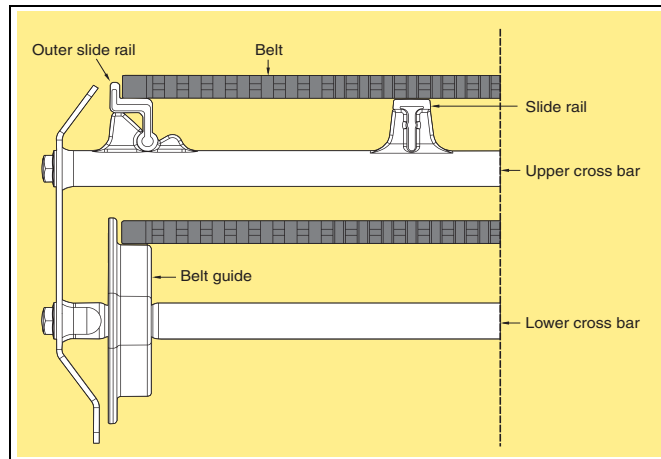

Technical characteristics

Belt width	608 mm	
Modular belt weight (Acetal)		
Radius flush grid	4,57 kg/m	
Flat top belt	4,78 kg/m	
Modular belt height		
Radius flush grid	13 mm	
Flat top belt	10 mm	
Belt pitch	25,4 mm	PO
Max. permissible belt tension		
Belt width 304	670 N	X70X
Belt width 456 and 608	1000 N	
With bend	1000 N	
Without bend	1200 N	X85X
Temperature range (Acetal)	1 °C to +40 °C	
	For other temperatures request for quotation	X180X
		X300X

Tools and accessories

The belt should be pretensioned with a return slack of about 25 mm. Too much belt slack is a safety risk as the belt can hang below the side of the conveyor beam. A belt tensioner tool (51 18803) is available in order to facilitate installation of the belt and minimize the amount of slack in the return belt.

Ordering information

The belt is delivered in assembled 1 m lengths. To calculate the total length required, remember to add for belt consumed by the idler and drive units.

WL 222X
WL 273X
WL 374X
WL 526X
WL 678X
CSX
GRX
FSTX
TR
APX
IDX

Modular belts

Radius flush grid belt, Wet



Plain belt

Belt material Acetal (POM)
Pin material Acetal (POM),
white
Length 1 m
608 mm wide, White
608 mm wide, Blue

WLTP 1A608L W
WLTP 1A608L WB

Flat top belt



Flat top belt

Belt material Acetal (POM)
Pin material Acetal (POM), white
Length 1 m
608 mm wide

WLTP 1B608 W

Radius flush grid belt, Dry



Plain belt

Belt material Acetal (POM)
Pin material Polyamide (PA),
brown
Length 1 m
608 mm wide, White
608 mm wide, Blue

WLTP 1A608L
WLTP 1A608L B

Radius flush grid belt, Wet



Plain belt

Belt material Acetal (POM)
Pin material Acetal (POM),
white
Length 1 m
608 mm wide, White
608 mm wide, Blue

WLTP 1A608L W
WLTP 1A608L WB

Belt tensioner tool for radius flush grid

Belt tensioner tool

5118803

Radius flush grid belt, Wet (Spare part - Available as request for quote item)



Plain belt

Belt material Acetal (POM)
Pin material Acetal (POM),
white
Length 1 m
608 mm wide, White
608 mm wide, Blue

WLTP 1A608 W
WLTP 1A608 WB

Note! For use with belt delivered before April 2019

Radius flush grid belt, Wet (Spare part - Available as request for quote item)



Plain belt

Belt material Acetal (POM)
Pin material Acetal (POM),
white
Length 1 m
608 mm wide, White
608 mm wide, Blue

WLTP 1A608 W
WLTP 1A608 WB

Note! For use with belt delivered before April 2019

Radius flush grid belt, Dry (Spare part only)



Plain belt

Belt material Acetal (POM)
Pin material Polyamide (PA),
brown
Length 1 m
608 mm wide, White
608 mm wide, Blue

WLTP 1A608
WLTP 1A608 B

Note! For use with belt delivered before April 2019

PO

X70X

X85X

X180X

X300X

WL
222X

WL
273X

WL
374X

WL
526X

WL
678X

CSX

GRX

FSTX

TR

APX

IDX

Conveyor Beams - Introduction

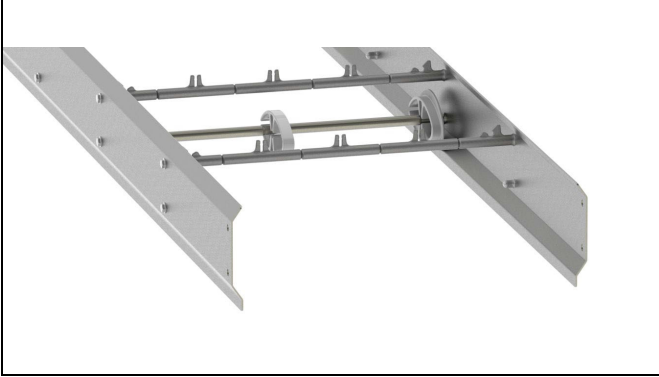

Conveyor frame structure

when connecting to an End drive unit is 844 mm. This ensures a sufficient amount of return belt tension directly after the drive sprocket to avoid slack close to the sprocket wheel. The return belt hanging between the first two belt guides provides this belt tension (called back tension). For more information see WLX Engineering guidelines.

Connecting brackets have to be ordered separately when joining End drives, idler ends, conveyor beams, etc.

When joining two conveyor beams, a beam spacer kit must be ordered separately.

Conveyor dimensions

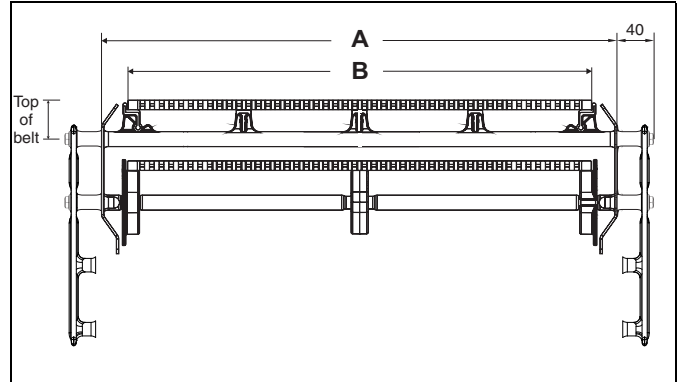

	WL678X
Conveyor width A	678 mm
Usable belt width B	608 mm
Top of belt:	
WLTP 1A	52 mm
WLTP 1B	49 mm

Frame profiles and cross bars

In order to facilitate cleaning, the top belt can be lifted up and the outer slide rails can be folded back.

For hygiene reasons, the WLX system is based on an easy-to-clean, free hanging return belt.

Elongation of the belt due to load is normally evenly distributed on the return side and along the whole conveyor, and placement of the belt guides for the return belt is critically important for proper conveyor system performance. Conveyor beams can be ordered from 142 mm up to 3000 mm and are always pre-engineered and configured according to the rules that must be followed.

Conveyor beams are normally not symmetrical, which is why they have an upstream and downstream end. An arrow label on the conveyor beam side indicates the appropriate top belt travel direction to ensure correct assembly.

Components such as plain bends, etc., cannot be placed too close to an End drive unit. Therefore, the minimum permissible length for conveyor beam sections

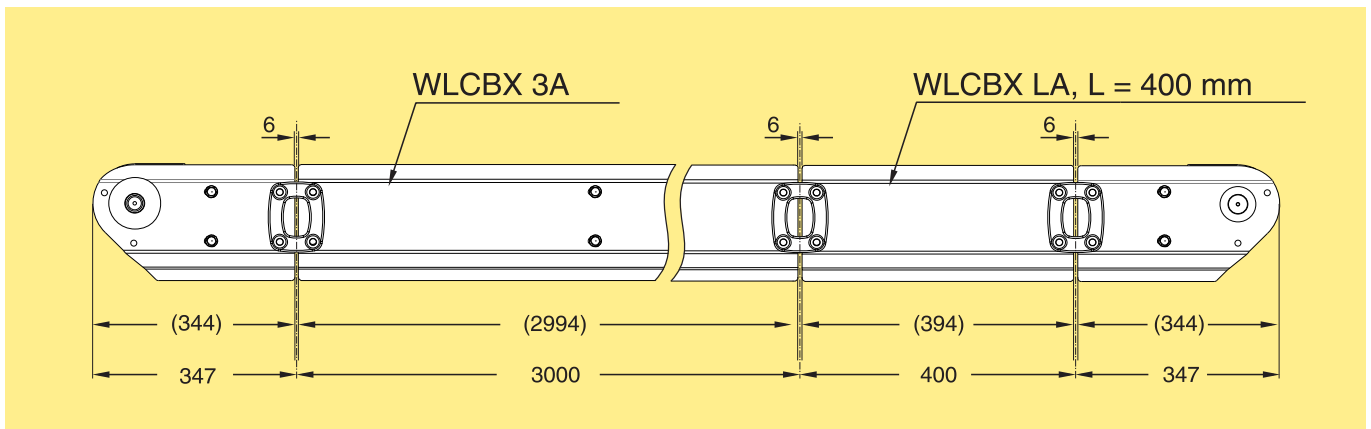

Technical specifications

Minimum permissible conveyor beam length to be connected:

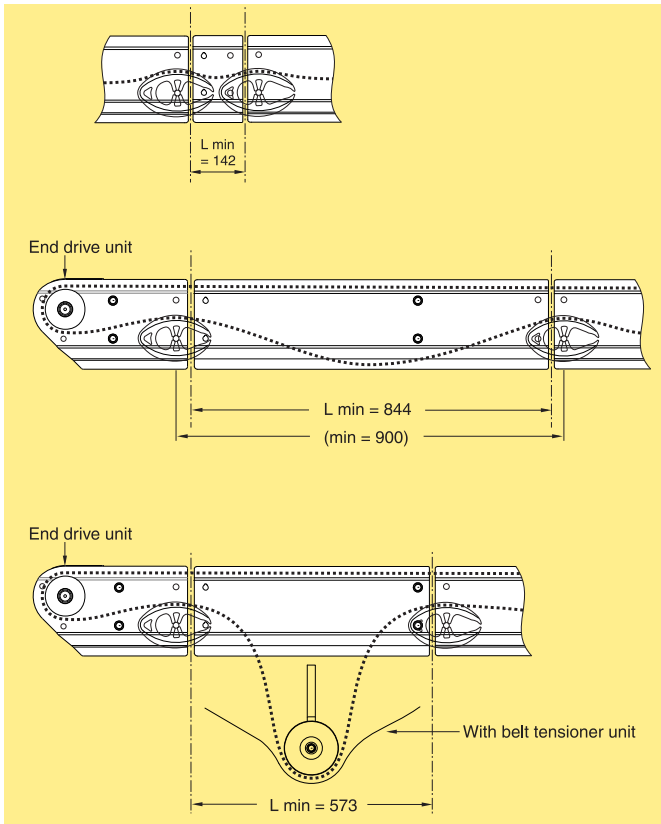

In order to simplify the cleaning process FlexLink can offer belt lift arms for straight conveyors. Contact FlexLink for more information.

- PO
- X70X
- X85X
- X180X
- X300X

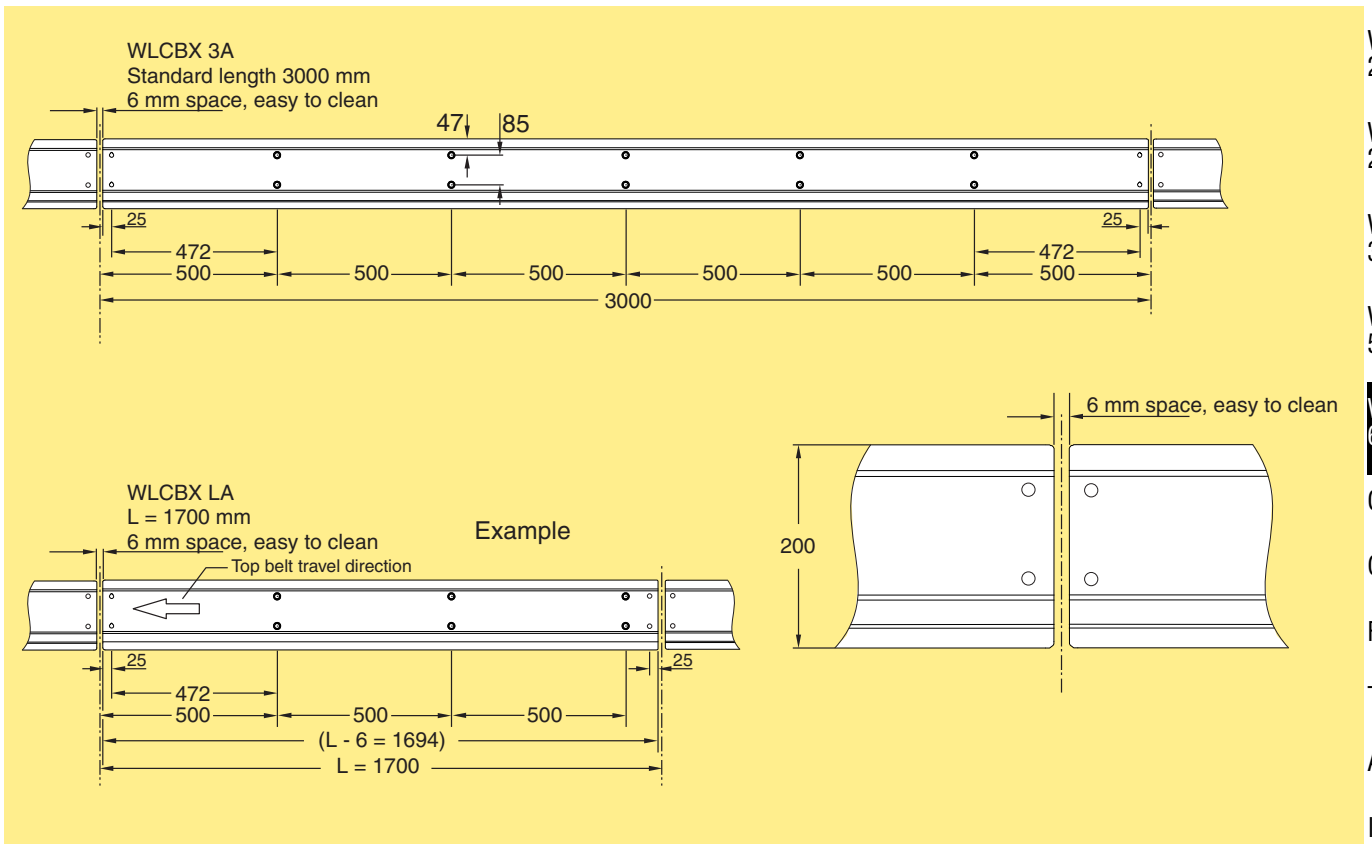

- WL 222X
- WL 273X
- WL 374X
- WL 526X
- WL 678X
- CSX
- GRX
- FSTX
- TR
- APX
- IDX

Conveyor beam, Easy Clean

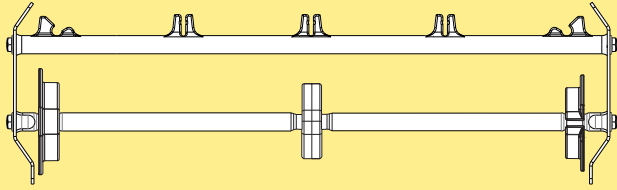

Conveyor beam, WL678X
 Length 3 m (3000 ±1,2 mm) **WLCBX 3A678**
 Length to order (142- 2999 mm) **WLCBX LA678**
 Weight, 1 m, incl. belt: 25 kg/m

Connecting bracket kit

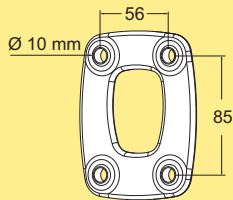

Connecting Bracket
 For beam
 Including 4 pcs M10 screws **WLCJX 10X56**

Beam support brackets

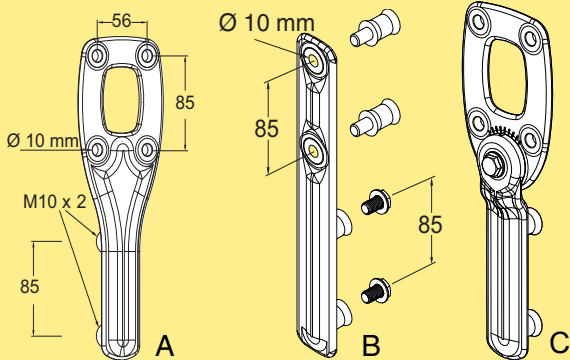

Beam support bracket (A) **WLCSX 10X56**
 Including 6 pcs M10 screws

Beam support bracket (B)
 Including 2 pcs M10 screws and
 2 pcs spacer WLRDX M10X25 **WLCSX 10**

Beam support bracket (C)
 Adjustable ±40° **WLCSX 10X56V40**

Beam spacer Kit for WL678

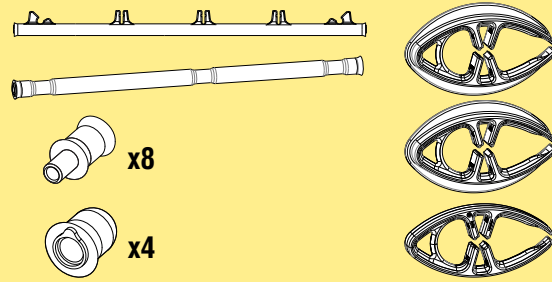

x8

x4

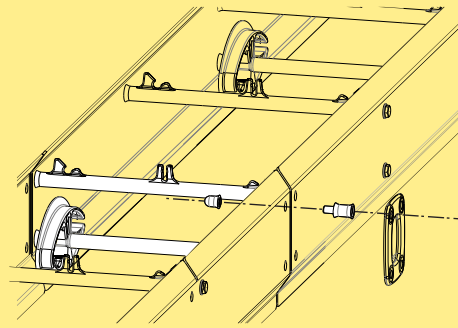

Beam spacer kit **WLCEX A678**

Recommended Torx tool for fasten spacer
 Size T30

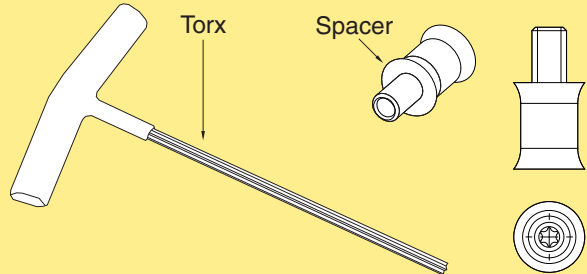

Slide rail

Slide rail

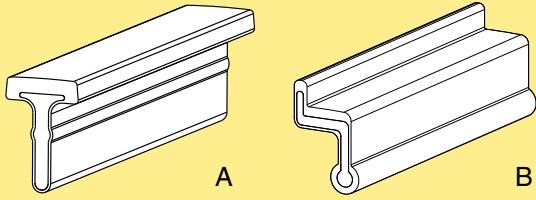

Slide rail, length 3 m
Slide rail (A)
Outer slide rail (B)

WLCRX 3
WLCRX 3 B

Connecting Strip

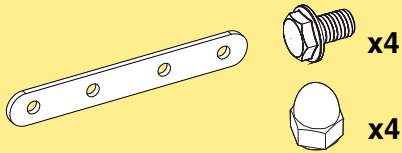

Connecting strip kit
Contains 10 pcs.

WLAHX 100

Drill fixture for connecting strip

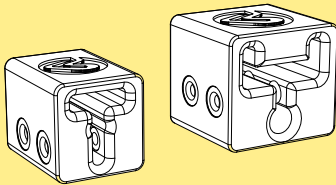

Contains drill fixtures for both
WLCRX 3 and WLCRX 3B

5118922

PO

X70X

X85X

X180X

X300X

WL
222X

WL
273X

WL
374X

WL
526X

WL
678X

CSX

GRX

FSTX

TR

APX

IDX

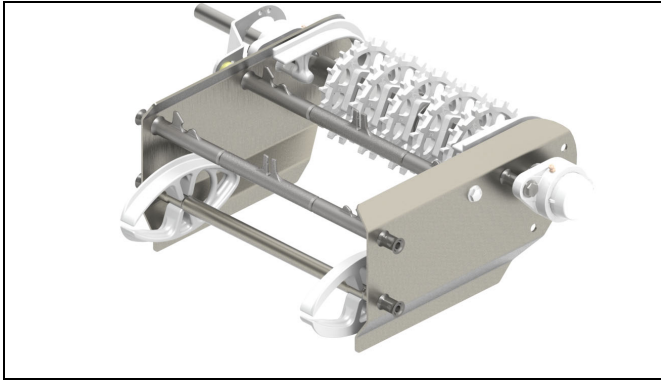

End drive unit

Technical specifications

Maximal speed..... 40 m/min
 Number of teeth on sprocket wheel ... 16

Belt tensioner unit

A belt tensioner unit should always be placed near the End drive unit and its use is recommended:

- for long conveyors >20 meters
- for long conveyors >15 m and a speed of >30 m/min
- for conveyors with frequent starts/stops, especially if the load is high
- if an End drive unit needs to be placed close to a plain bend
- if an End drive unit needs to be placed on the lower part next to a conveyor slope section
- for short conveyors where the belt slack length is insufficient to lift the belt for cleaning

End drive units

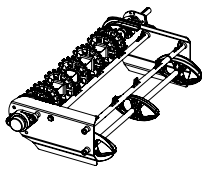
Size	Direct drive, no slip clutch
Drive unit types	 F, V

Drive unit types

A soft motor start is recommended for use with high-speed and long conveyors. This is because these types of modular belts are quite heavy, and the free hanging return belt can begin to oscillate momentarily during startup.

A grease nipple is included in all flange bearings. The bearings are initially filled with FDA-approved, food-grade grease (NSF H1).

End drive units including SEW motors IP 65, can be ordered with food-grade oil and stainless steel hollow shafts in the web-based configurator.

Motor specifications

Motors are available for 230/400 V, 50 Hz and 230/460 V, 60 Hz. Variable speed motors are SEW Movimot, 380–500 V. Note that variable speed motors include a control box that adds 120 mm to the width of the motor.

IP55 available with standard oil.

IP65 available with food grade oil.

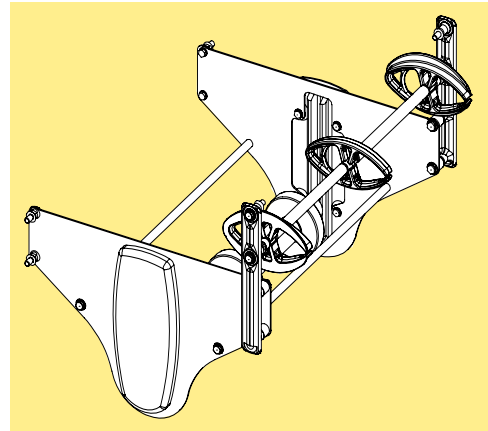

Ordering information

Drive units with motors must be specified using the web-based configurator. The configurator provides detailed information and step-by-step guidance in the specification process. A product code string is generated, containing the specification details. See next page for examples of code strings.

Drive units *without* motors can be ordered using the designations in the catalogue.

- Connecting brackets have to be ordered separately.
- Slide rail must be ordered separately.

Dimension

Note that dimensions relating to drive unit motors depend on the motor specified during the configuration.

Drive units – configuration strings

Below are two examples of text strings obtained from the configurator with explanations.

Drive unit with fixed speed motor

Item no	A	B	D	E	G	H	I
	HNP	- L	- V4	- SA37	- 50/230	- 0,18kW	- TF

Drive unit with variable speed motor

Item no	A	B	D	E	F	G	J	K
	HPV	- L	- V6-15	SA37	- MM03	- 50/380-500	- C	- P

Item no - Drive type

WLEBX: End drive

A – 0-Unit

HNP: Direct drive, no slip clutch
V: Variable speed

B – Motor position

L: Left
 R: Right

D – Speed

V...: Fixed speed... m/min
 V... -...: Variable speed range...-... m/min

E – Gearbox

SA37: SEW motor type SA37
 WA30: SEW gear box type WA30

F – Movimot size

MM03: SEW Movimot type, 0,37 kW
 MM05: SEW Movimot type, 0,55 kW
 MM07: SEW Movimot type, 0,75 kW
 (position is omitted for fixed speed motors)

G – Electrical environment

50/230: 50 Hz, 230 V
 50/400: 50 Hz, 400 V
 60/230: 60 Hz, 230 V
 60/460: 60 Hz, 460 V
 50/380-500: SEW Movimot variable speed motor

H – Motor power

... kW: Motor power, kW
 (position is omitted for variable speed motors
 see position F)

I – Thermal protection

No: No thermal protection
 TF: Thermal protection type TF
 TH: Thermal protection type TH
 (position is omitted for variable speed motors)

J – Hybrid cable

No: No hybrid cable
 C: Hybrid cable included in SEW Movimot
 (position is omitted for fixed speed motors)

PO
 X70X

K – Fieldbus

No: No fieldbus
 P: Profibus fieldbus, maintenance switch
 D: DeviceNet fieldbus, maintenance switch
 (position is omitted for fixed speed motors)

X85X
 X180X
 X300X

WL
 222X

WL
 273X

WL
 374X

WL
 526X

WL
 678X

CSX

GRX

FSTX

TR

APX

IDX

End drive unit Easy Clean, Radius flush grid 678

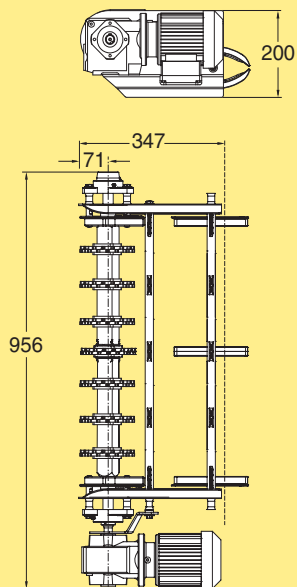

End drive unit **WLEBX A678**
 Fixed/variable speed*
 Without motor:
 Transmission on left side **WLEBX0A678NLP**
 Transmission on right side **WLEBX0A678NRP**

* Use online configurator when ordering
 Effective track length: 0,80 m
 Weight, incl belt: 24 kg

End drive unit Easy Clean, Flat top 678

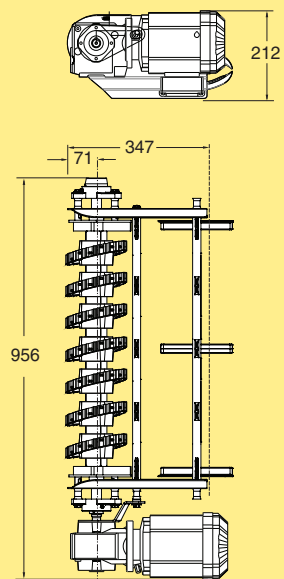

End drive unit **WLEBX B678**
 Fixed/variable speed*
 Without motor:
 Transmission on left side **WLEBX0B678NLP**
 Transmission on right side **WLEBX0B678NRP**

* Use online configurator when ordering
 Effective track length: 0,80 m
 Weight, incl belt: 25 kg

End drive unit S, Radius flush grid 678

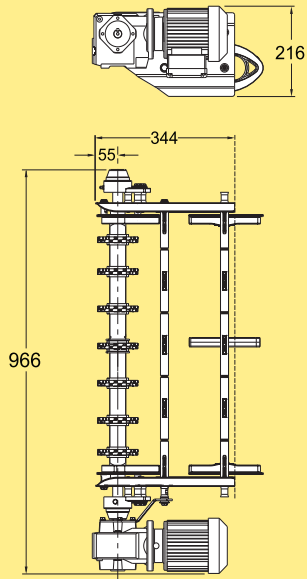

End drive unit
 Fixed/variable speed* **WLEBX A678 S**
 Without motor:
 Transmission on left side **WLEBX0A678NLP S**
 Transmission on right side **WLEBX0A678NRP S**

* Use online configurator when ordering
 Effective track length: 0,75 m
 Weight, incl belt: 23,2 kg

End drive unit J, Radius flush grid 678

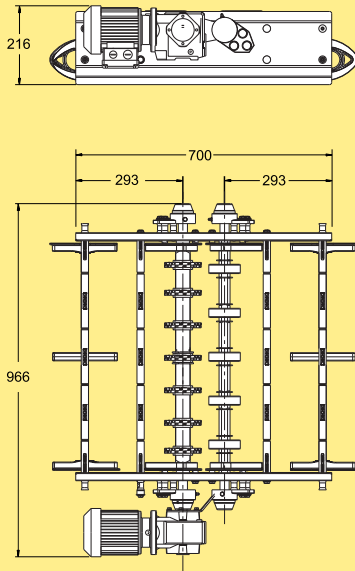

End drive unit
 Fixed/variable speed* **WLEBX A678 J**
 Without motor:
 Transmission on left side **WLEBX0A678NLPJ**
 Transmission on right side **WLEBX0A678NRPJ**

* Use online configurator when ordering
 Effective track length: 1,5 m
 Weight, incl belt: 39,1 kg

Belt tensioner unit

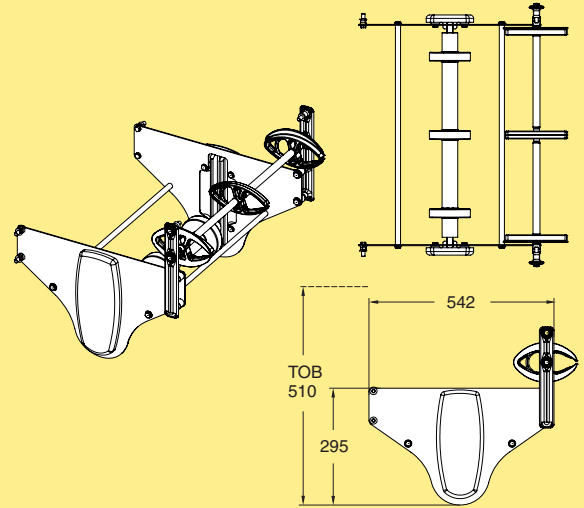

Belt tensioner for: WL678X **5118763**

Required extra belt length **0,55 m**

Weight, incl belt: 23 kg

- PO
- X70X
- X85X
- X180X
- X300X
- WL 222X
- WL 273X
- WL 374X
- WL 526X
- WL 678X**
- CSX
- GRX
- FSTX
- TR
- APX
- IDX

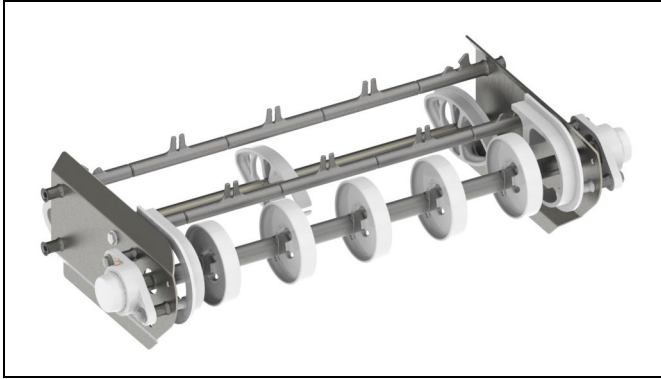

Idler end unit

Chain guidance at end of conveyor

The idler end unit is used to guide the chain from the return side of the conveyor up to the top side with a minimum of friction. The chain is guided by two or more idler wheels on a common, rotating shaft supported by ball bearings.

Ordering information

- Connecting strips are included with the idler end units.
- Slide rail must be ordered separately.

Idler units

Idler end unit, WL678

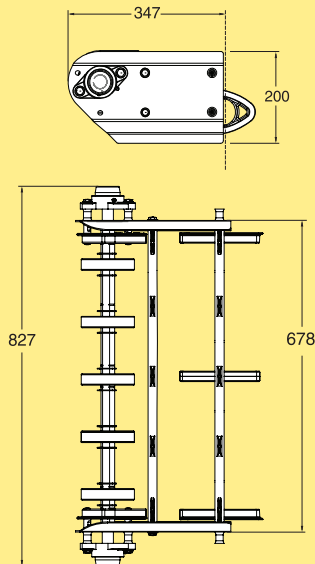

Idler end unit (For conveyors with plain bends)

WLEJX 300A678

Idler en unit (Only for straight conveyors)

WLEJX 300B678

** Use online configurator when ordering*
 Effective track length: 0,80 m
 Weight, incl belt: 22 kg

Idler end unit, WL678 S

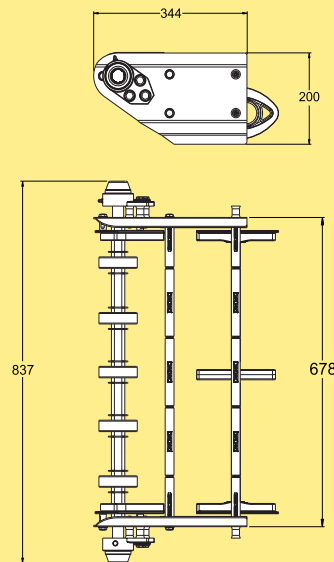

Idler end unit

WLEJX 300A678 S

** Use online configurator when ordering*
 Effective track length: 0,75 m
 Weight, incl belt: 18,2 kg

Plain Bends - Introduction

When using radius flush grid belts in plain bends, the belt pull force will be concentrated on the outer part of the belt. A certain straight section is needed before and after the bend in order to transfer the load between the outer belt section and evenly distribute it to the straight belt section. This is critical before entering another plain bend, end drive unit, etc. This required straight section is always integrated in the plain bend itself (300 mm for WL374X, 450 mm for WL526X, and 600 mm for WL678X).

Plain bend placement, as for all other Flexlink conveyors, should always be considered. A plain bend placed too far downstream on a conveyor generates unnecessary belt pull. Also, placement of a plain bend too close to an end drive unit can lead to an unnecessary slack increase and a separate slack unit must be added. Always use the Flexlink calculation tool (FLCT) to calculate the resulting pull forces.

Plain bend, Easy Clean, 45°

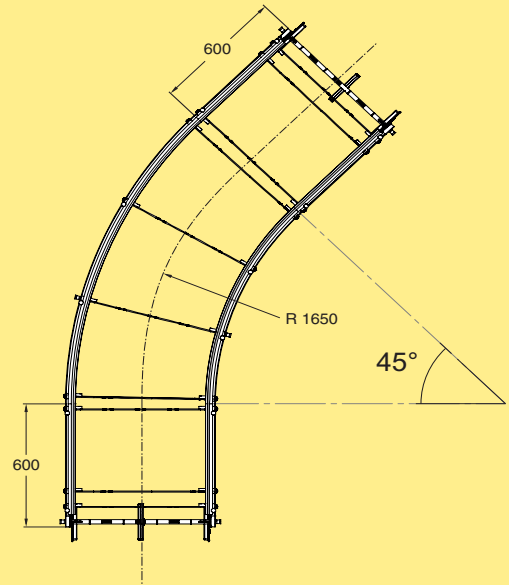

Plain bend, 45°±1°

R=1650±10 mm, WL626

WLBPX 45A678

* Use online configurator when ordering

Effective track length: 5,5 m

Weight, incl belt: 77 kg

PO

X70X

X85X

X180X

X300X

WL 222X

WL 273X

WL 374X

WL 526X

WL 678X

CSX

GRX

FSTX

TR

APX

IDX

Plain bend, Easy Clean 30°

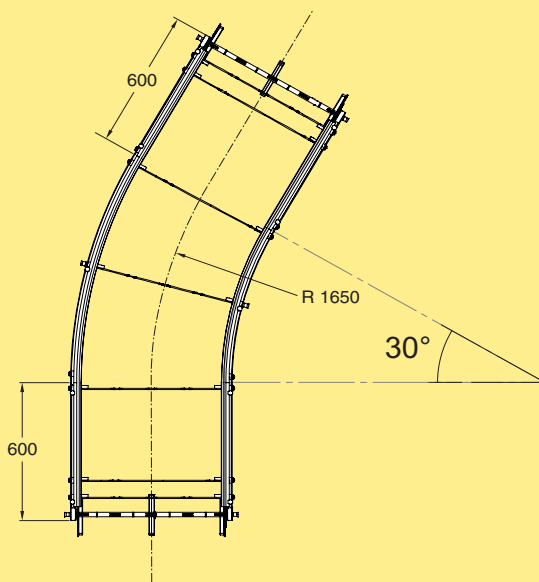

Plain bend, 30°±1°

R=1650±10 mm

WLBPX 30A678

* Use online configurator when ordering

Effective track length: 4,5 m

Weight, incl belt: 66 kg

Plain bend, Easy Clean 60°

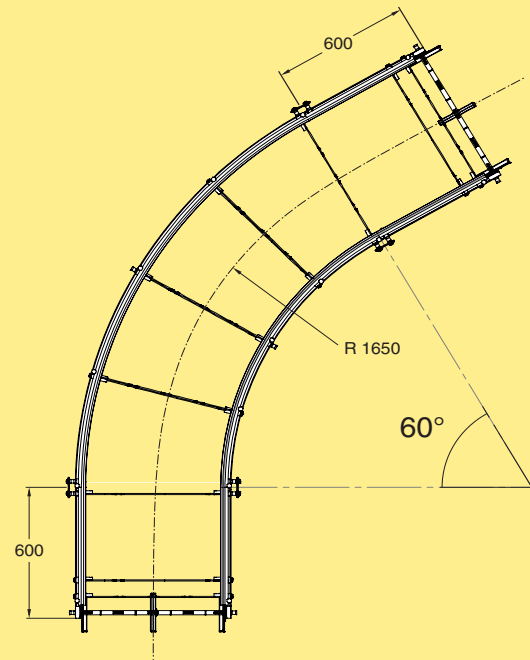

Plain bend, 60°±1°

R=1650±10 mm

WLBPX 60A678

* Use online configurator when ordering

Effective track length: 6,5 m

Weight, incl belt: 91 kg

Plain bend, Easy Clean 90°

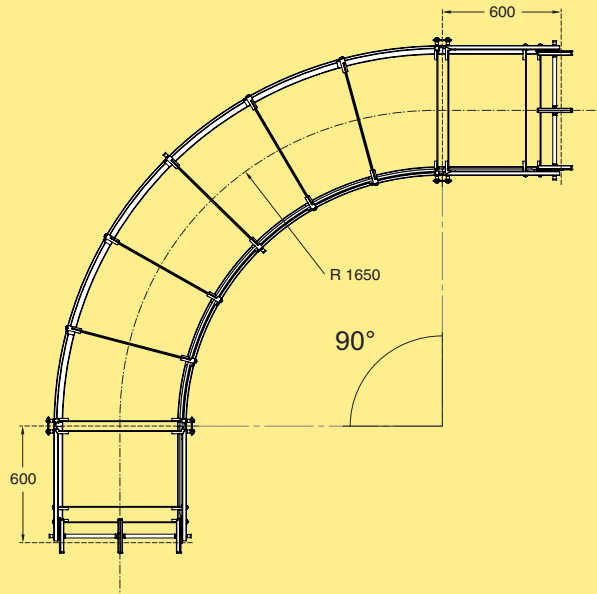

Plain bend, 90°±1°
R=1650±10 mm **WLBPX 90A678**

* Use online configurator when ordering
Effective track length: 8,6 m
Weight, incl belt: 113 kg

Vertical bend, Easy Clean, 5° (pos.)

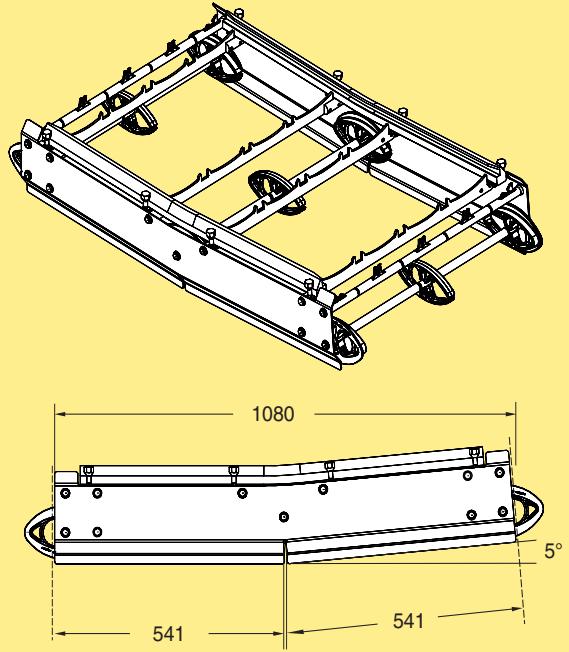

Vertical bend 5°, pos **WLBVX 5A678P**

* Use online configurator when ordering
Effective track length: 2,1 m
Weight, incl belt: 39 kg

Vertical bend, Easy Clean, 5° (neg.)

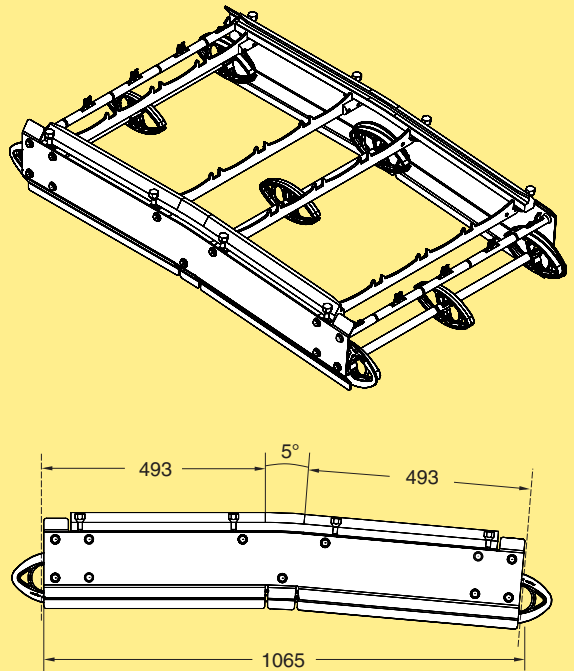

Vertical bend 5°, neg **WLBVX 5A678N**

* Use online configurator when ordering
Effective track length: 2,1 m
Weight, incl belt: 39 kg

Support System Modules - Introduction

Conveyor supports

Support modules must be specified using the web-based configurator. There, a product code string is generated that contains the specification details (E.g., WLUFX S01-WL374X-900).

Support module, single leg

Top of belt
660 - 1500

Adjustable foot
± 33

Connecting brackets

Support module, single leg **WLUFX S04**

Support module, single leg WLUFX S04

Parameter	Option
Top of belt:	660-1500 mm
Foot type:	XCFSX 16x80 H XCFSX 16x80 HA XCFSX 16x80 XCFSX 16x80 A
Bracket type:	WLCSX 10X56 WLCSX 10

Support module, type H

678
526
374
273
222

Top of belt
660 - 1500

Adjustable foot
± 33

Connecting brackets

Support module type H **WLUFX S01**

Support module type H, WLUFX S01

Parameter	Option
Platform	WL222X WL273X WL374X WL526X WL678X
Top of belt:	660-1500 mm
Foot type:	XCFSX 16x80 H XCFSX 16x80 HA XCFSX 16x80 XCFSX 16x80 A
Bracket type:	WLCSX 10X56 WLCSX 10 WLCSX 10X56V40

Foot holder for adjustable foot

M10 (x2)

85

46

31

M16
Depth 100

Foot holder
Including 2 pcs M10 screws **XCFCX 16x100**

Adjustable foot

M16

243

37 Max

66 Min

Ø 80

Ø 15 mm

Adjustable foot

Option
M16
M16, Anchoring
M16, EHEDG/3A
M16, EHEDG/3A, Anchoring

XCFSX 16x80
XCFSX 16x80 A
XCFSX 16x80 H
XCFSX 16x80 HA

