

Conveyor system X85X - links and chains

Each link kit contains 10 links, 10 plastic pivots, and 10 stainless steel pins, unless otherwise specified.

Material abbreviations: See page III.

Plain chain

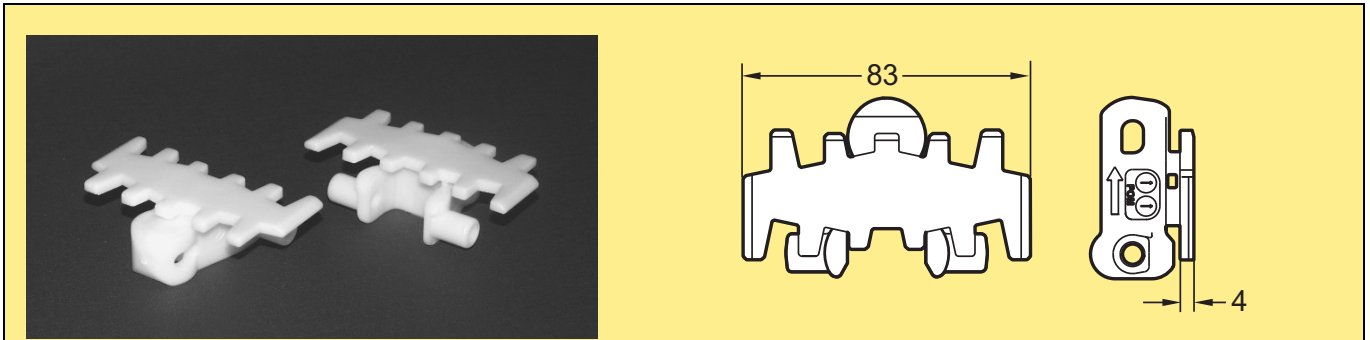

Chain type XBTP 5A85 B: max chain tension 300 N. Steel pin is zinc plated steel.

Chain	Link(s)	Link kit(s)	Dimensions	Link weight	Material, link	Material, pivot
XBTP 5A85	5110431	5110529		27 g	POM B	See page III
XBTP 5A85 C	5110484	5110533		27 g	POM D	See page III
XBTPX 5A85	5059652	5110512		27 g	POM A	See page III

Universal chain

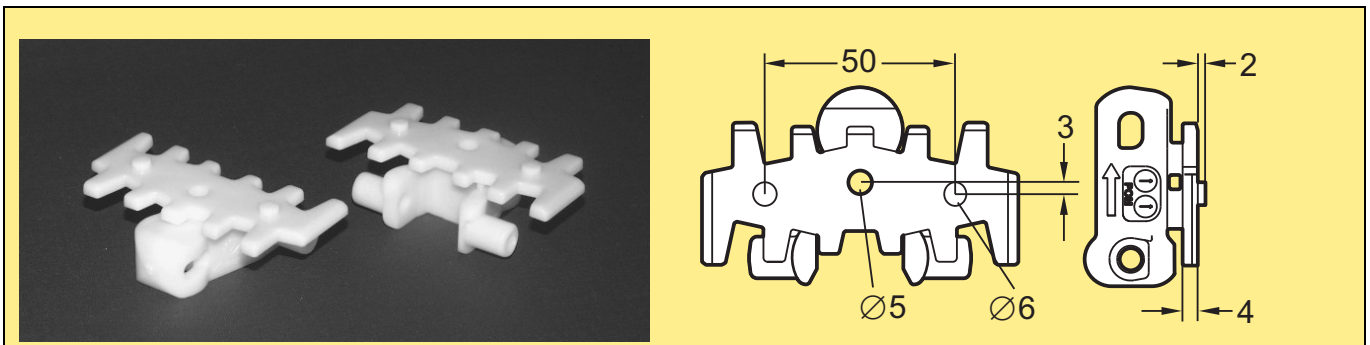

To attach customer specific cleat or fixture. The link has a hole for an M5 screw. An M5 nut will fit inside the link.

Chain	Link(s)	Link kit(s)	Dimensions	Link weight	Material, link	Material, pivot
XBTF 5A85 U	5110375	5110526		27 g	POM B	See page III

Friction top chain

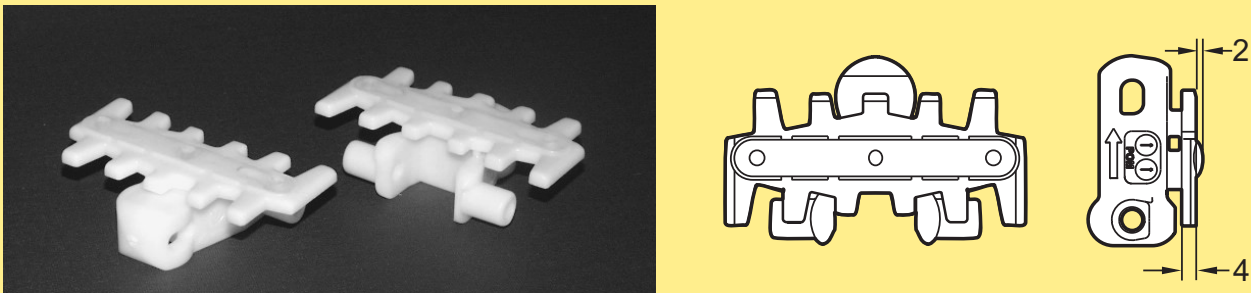

When ordered as XBTP 5A85 F2, the chain is delivered with one plain link between each friction top link. Friction insert is polyether-polyamide. Slope <math><30^\circ</math>. Paper bags, cardboard boxes.

Chain	Link(s)	Link kit(s)	Dimensions	Link weight	Material, link	Material, pivot
XBTP 5A85 F	5110459	5110518		29 g	POM B	See page III
XBTP 5A85 FP	5110459	5110518		29 g	POM B	See page III

Flat top friction chain

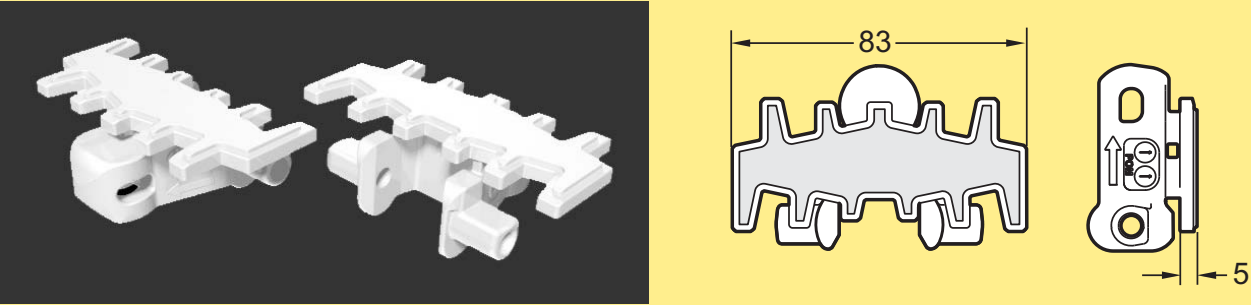

Friction insert is polyether-polyamide. Slope <math><30^\circ</math>. Light goods: blister packs, small boxes, etc.

Chain	Link(s)	Link kit(s)	Dimensions	Link weight	Material, link	Material, pivot
XBTP 5A85 FA	5110378	5110528			POM B	See page III

Flexible cleat chain

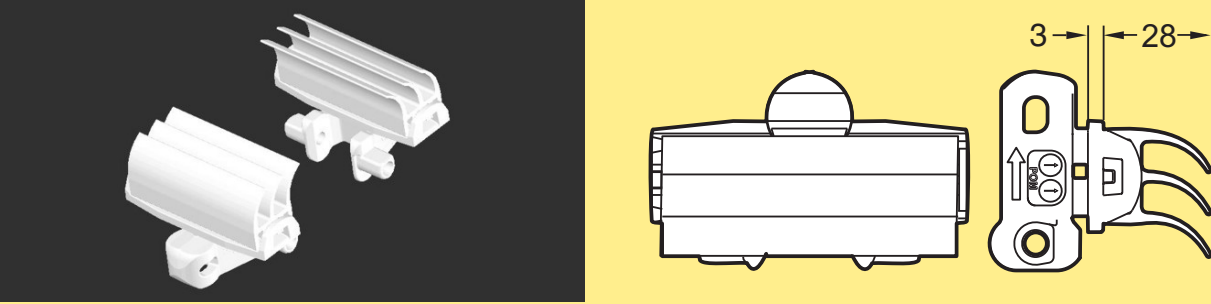

Max product weight for XBTE 5A85 C: 2,0 kg. Flexible cleat is thermo-plastic elastomer. Wedge transport. Soft, flexible surface for sensitive items. Link kit 5110515: 10 flexible cleat tops.

Chain	Link(s)	Link kit(s)	Dimensions	Link weight	Material, link	Material, pivot
XBTE 5A85 C	5059812	5110363		40 g	POM B	See page III
		5110515				

Flexible cleat chain

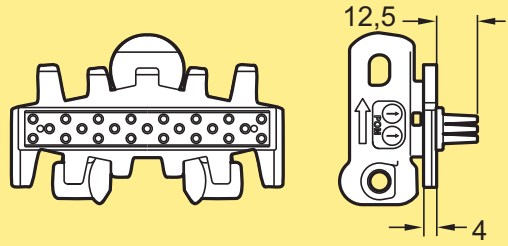
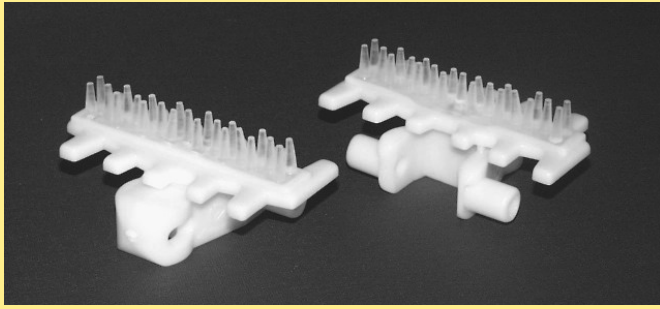

Max. product weight for XBTE 5A85 B: 3,0 kg. Flexible insert is polyether-polyamide. Wedge transport. Bags, bottles and cans. Horizontal transport of light products e.g. paper bags.

Chain	Link(s)	Link kit(s)	Dimensions	Link weight	Material, link	Material, pivot
XBTE 5A85 B	5110461	5110522		31 g	POM B	See page III

Flexible cleat chain

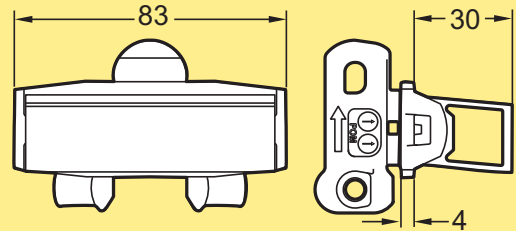
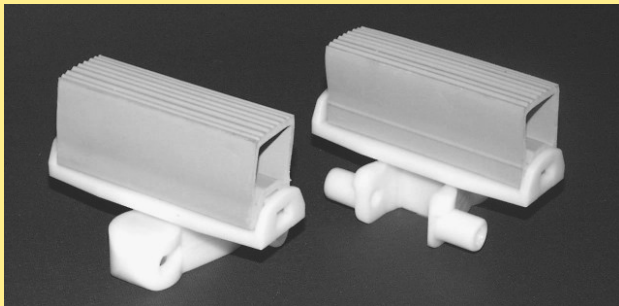

Max. product weight for XMTE 5 D: 4,0 kg. Flexible cleat is EPDM rubber. Wedge transport. Recommended for irregular shapes. Link kit 5056311: 10 flexible cleat tops.

Chain	Link(s)	Link kit(s)	Dimensions	Link weight	Material, link	Material, pivot
XBTE 5A85 D	5110381	5110582		66 g	POM B	See page III

Roller top chain

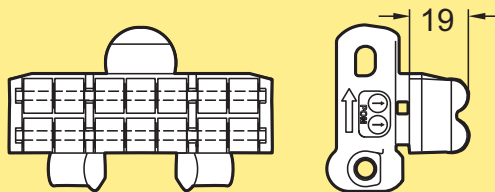
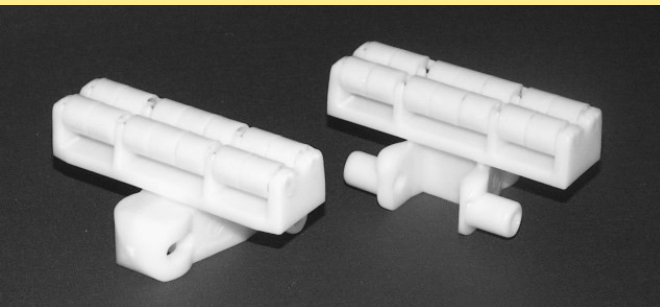

Link cannot be used together with plain links in conveyors with bends. Accumulation of parcels for lower pressure.

Chain	Link(s)	Link kit(s)	Dimensions	Link weight	Material, link	Material, pivot
XBTR 5A85	5110490	5110520		58 g	POM B	See page III
(3902819 Roller, order in multiples of 200 Pcs)						

Roller cleat chain

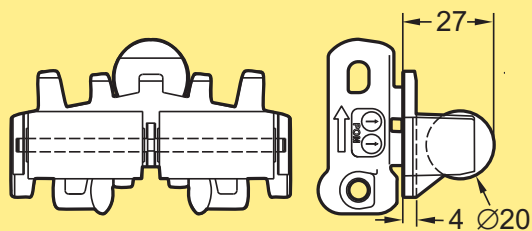
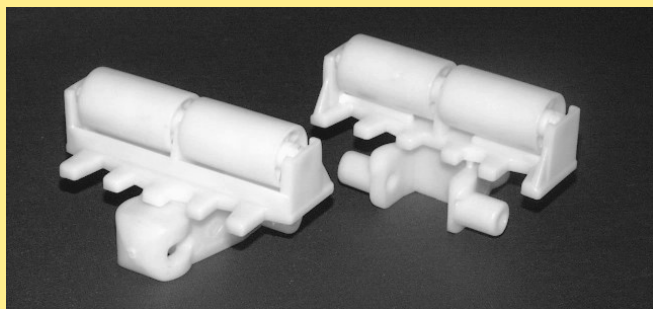

Roller support items in steel and aluminium. Accumulation of parcels for lower pressure. Cardboard boxes.

Chain	Link(s)	Link kit(s)	Dimensions	Link weight	Material, link	Material, pivot
XBTF 5A85X23 R	5110439	5110521		59 g	POM B	See page III