

Conveyor system X180 - links and chains

Each link kit contains 10 links, 10 plastic pivots, and 10 stainless steel pins, unless otherwise specified. Material abbreviations: See page III.

Plain chain

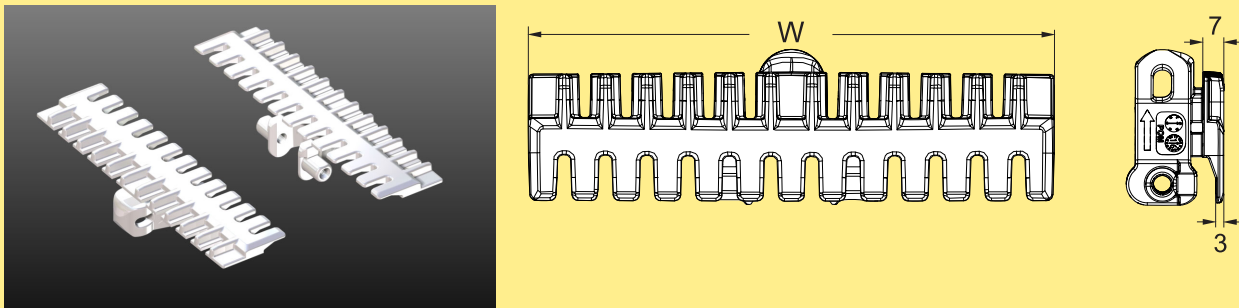

Chain	Link(s)	Link kit(s)	Dimensions	Link weight	Material, link	Material, pivot
XBTPX 3A180 K	5122767	5129849	W=175 mm	54 g	POM A	See page III

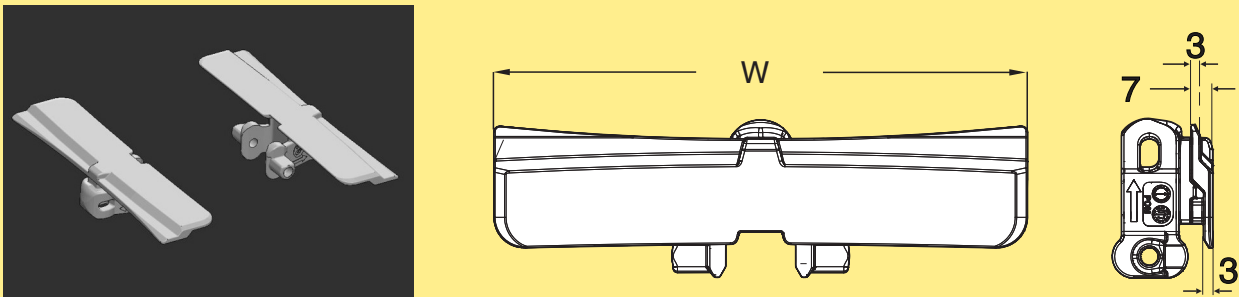

Chain	Link(s)	Link kit(s)	Dimensions	Link weight	Material, link	Material, pivot
XBTP 3A175	XBTL 175	5056651	W=175 mm	51 g	POM B	See page III
XBTP 3A175E	5122442	n.a.	W=175 mm	51 g	POM B COND	See page III
5122887	5122443	n.a.	W=175 mm	51 g	POM A Blue	See page III
XBTPX 3A175	XBTLX 175	5122929	W=175 mm	51 g	POM A	See page III

Friction top chain

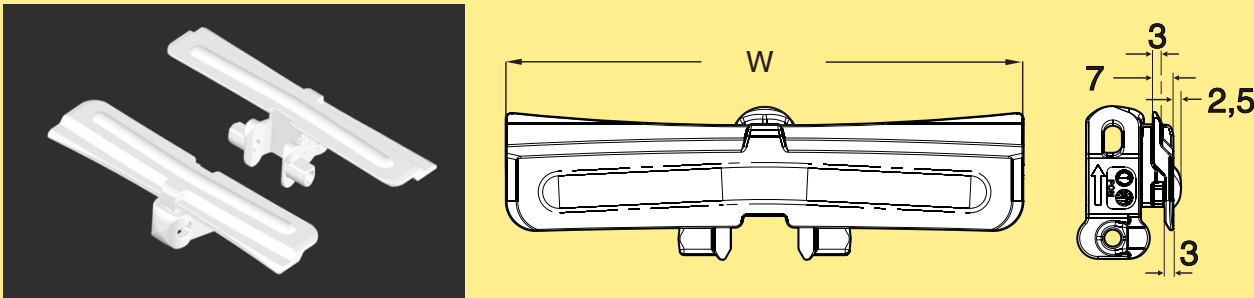

Friction insert is polyether-polyamide.

Chain	Link(s)	Link kit(s)	Dimensions	Link weight	Material, link	Material, pivot
XBTP 3A175 F	XBTL 175 F	5056653	W=175 mm	52 g	POM A	See page III

Introduction
X45
X45H
XS
XL
X65
XM
X70X
X85
X85X
XH
XK
X180
X180X
X300
X300X
XT
XTC
XK
WL
WL22X
WL273X
WL374X
WL526X
WL678X
IDX

Roller cleat chain

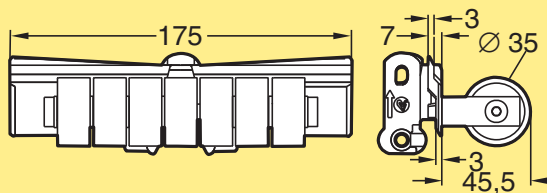
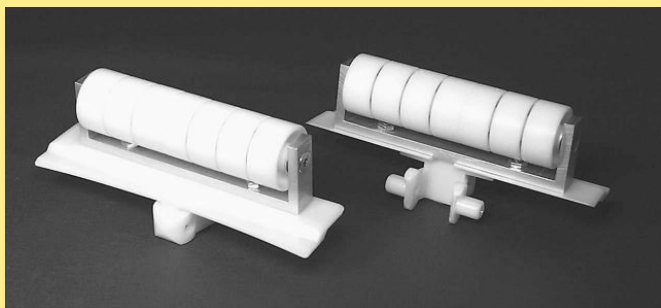

Note. Can only be ordered as a link kit. Roller support items in steel and aluminium. Vertical transportation of cardboard boxes. Link kit 5056654: 1 link + pivot + steel pin.

Chain	Link(s)	Link kit(s)	Dimensions	Link weight	Material, link	Material, pivot
See Note	XBTL 175X46 R	5056654		249 g	POM B	See page III