

Conveyor system X180X - links and chains

Each link kit contains 10 links, 10 plastic pivots, and 10 stainless steel pins, unless otherwise specified.

Material abbreviations: See page III.

Plain chain

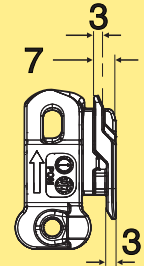
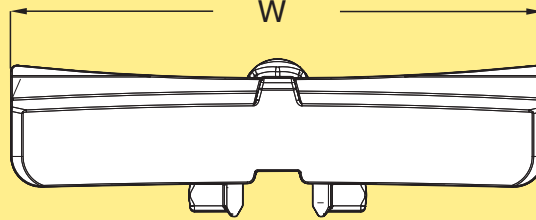
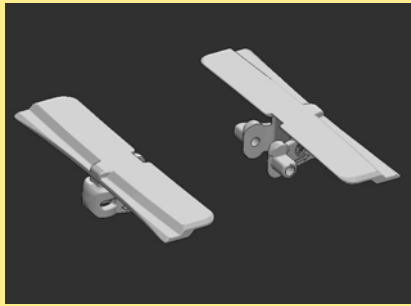

Chain	Link(s)	Link kit(s)	Dimensions	Link weight	Material, link	Material, pivot
XBTP 3A175	XBTL 175	5056651	W=175 mm	51 g	POM B	See page III
XBTP 3A175E	5122442	n.a.	W=175 mm	51 g	POM B COND	See page III
5122887	5122443	n.a.	W=175 mm	51 g	POM A Blue	See page III
XBTPX 3A175	XBTLX 175	5122929	W=175 mm	51 g	POM A	See page III

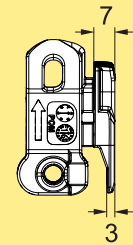
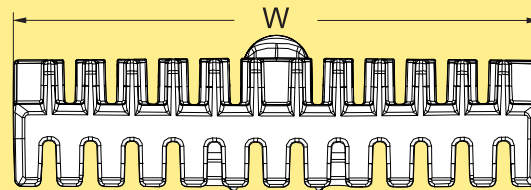

Chain	Link(s)	Link kit(s)	Dimensions	Link weight	Material, link	Material, pivot
XBTPX 3A180	5122767	5129849	W=175 mm	54 g	POM A	See page III

Friction top chain

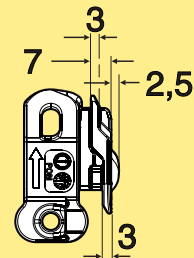
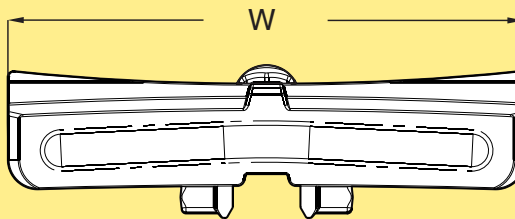
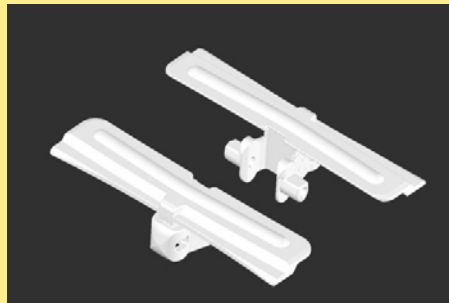

Friction insert is polyether-polyamide.

Chain	Link(s)	Link kit(s)	Dimensions	Link weight	Material, link	Material, pivot
XBTP 3A175 F	XBTL 175 F	5056653	W=175 mm	52 g	POM A	See page III

Roller cleat chain

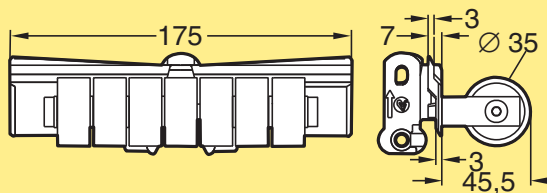
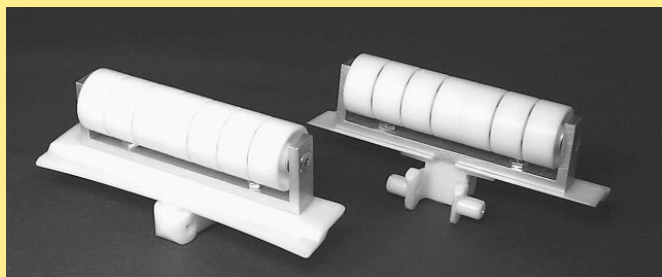

Note. Can only be ordered as a link kit. Roller support items in steel and aluminium. Vertical transportation of cardboard boxes. Link kit 5056654: 1 link + pivot + steel pin.

Chain	Link(s)	Link kit(s)	Dimensions	Link weight	Material, link	Material, pivot
See Note	XBTL 175X46 R	5056654		249 g	POM B	See page III

