

PRE-REQUISITES

Recommended tools

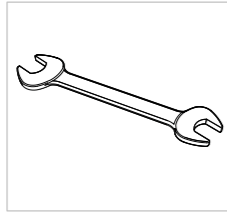

SAFETY



WARNING
The system must not be operated without safety equipment properly mounted.



WARNING
At installation, maintenance and service, make sure the motor is shut off.



WARNING
Pinch Point



CAUTION
Due to heavy weight - 2 person lift, or mechanical lift equipment.

PRODUCTS

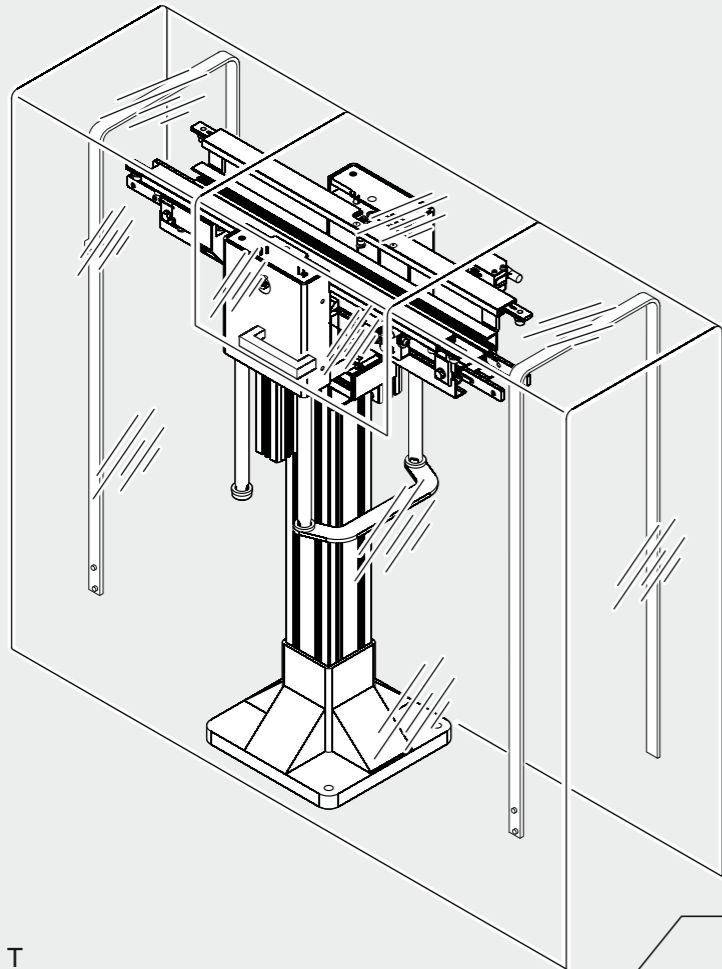
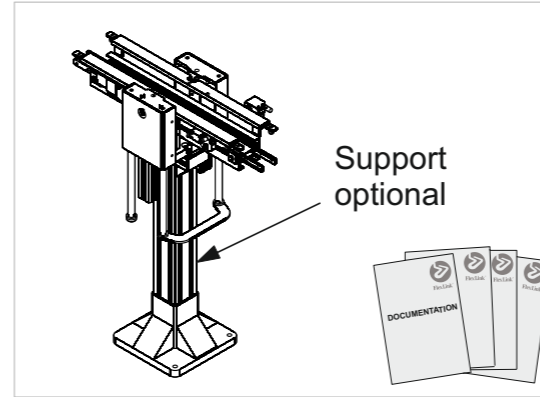

WARNING
Pinch Point

WARNING
The system must not be operated without safety equipment properly mounted.

Note 1: The cylinders are not equipped with tubing. When installing the tubing, it is important that the tubing have equal lengths from Y-connector to the connectors of the parallel cylinder connectors.

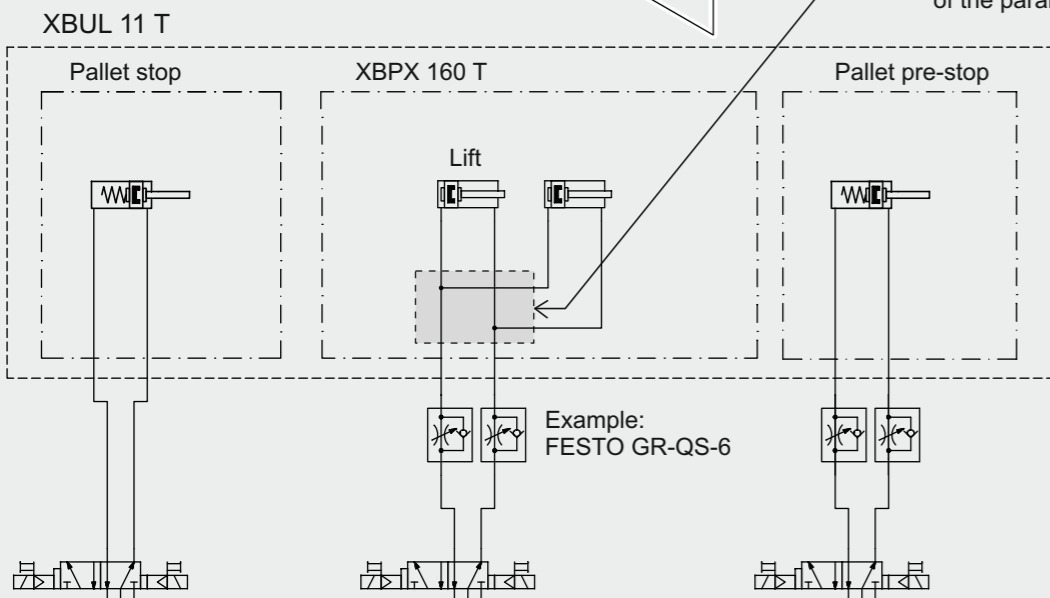
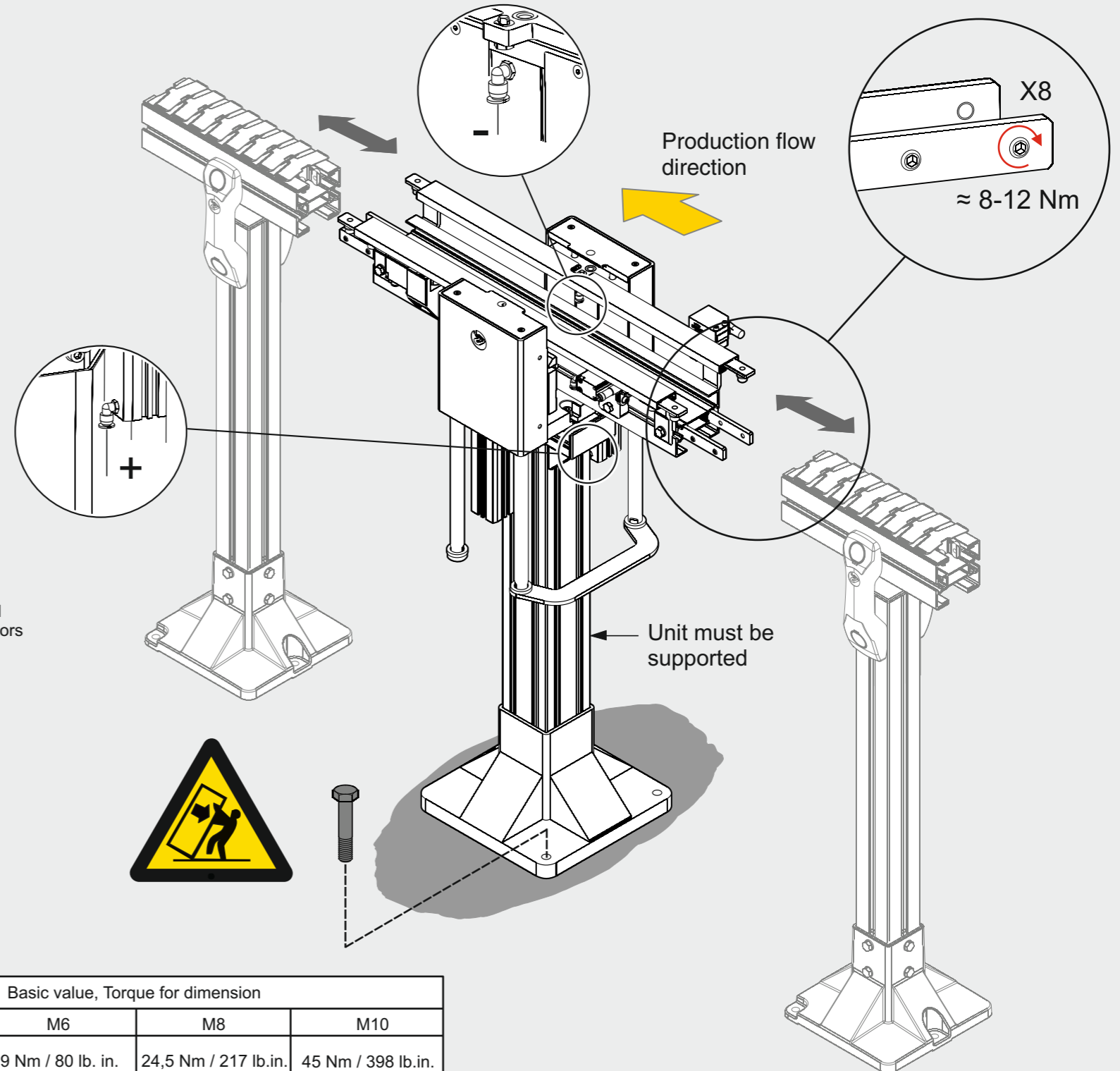

Basic value, Torque for dimension			
M5	M6	M8	M10
4 Nm / 35 lb. in.	9 Nm / 80 lb. in.	24,5 Nm / 217 lb.in.	45 Nm / 398 lb.in.

FlexLink Components AB
SE-41550 Göteborg
Sweden

We hereby declare that the following equipment is intended to be incorporated into a FlexLink conveyor system and thereby forming a machine. Operation is prohibited until it has been determined that the machine in which these products are incorporated, has been declared in conformity with the Machinery Directive 2006/42/EC, together with amendments which have entered into force as of the date of issue of this declaration, with particular reference to the essential health and safety requirements in connection with the design, construction and manufacture of the below specified equipment.

- Tunnel Locating Module, XBUL 11 T

ASSEMBLY INSTRUCTION

Tunnel Locating Module
XBUL 11 T

FlexLink Components AB



Svante Anderholm
Chief Operating Officer

Flexlink Components AB



Anders Jonsson
Responsible Technical file

FlexLink Components AB

