

Conveyor system X85

Contents

System information.....	161	Intermediate drive units, max 200 N	178
Conveyor modules	162	Intermediate drive unit H, max 875 N.....	179
Chains – introduction	163	Drive units for wedge conveyors	180
Chains	164	Transfers	181
Chain accessories	167	X-bends	181
Accessories for use with steel chain 5056849.....	167	Support components for X-bends	181
Conveyor beam – introduction	168	S-Transfer	181
Beams	169	Components for wedge track width adjustment	182
Beam accessories	169	Idler units	183
Slide rails	170	Bridges	184
Slide rail in hardened steel	172	Wheel bends.....	186
Drive and idler units – introduction	173	Wheel cover for Wheel bend	187
End drive units, max 1250 N	174	Plain bends.....	188
End drive units, max 800 N	175	Vertical bends.....	189
End drive units, max 300 N	175	Angle plates.....	190
Double drive units, max 1250 N	176	Front piece	191
Wheel bend drive unit, max 200 N	177	Drip trays	192

System information

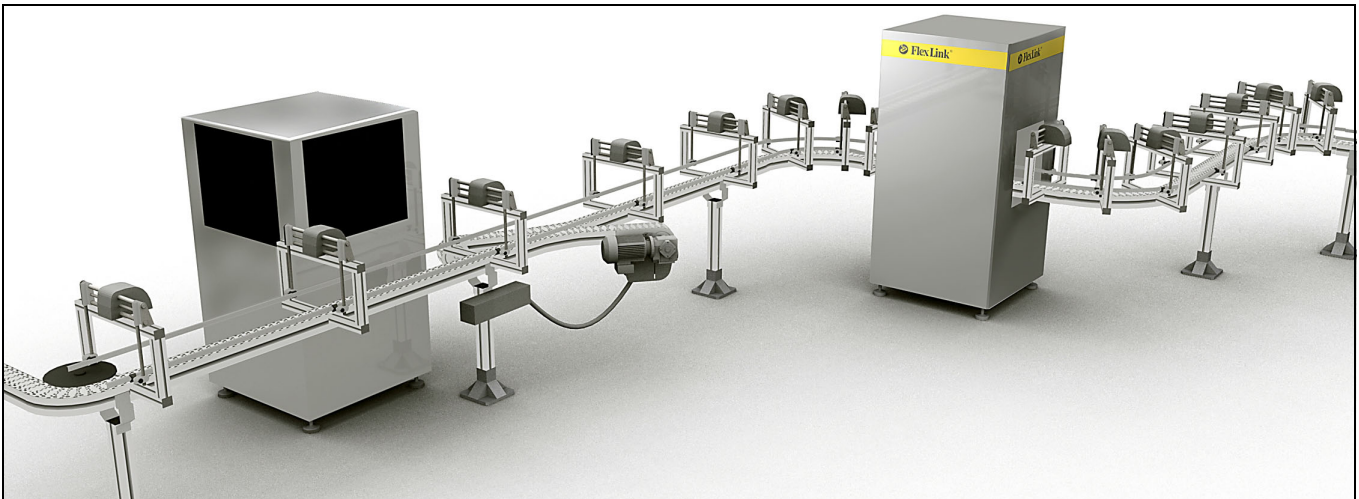

Chain width 83 mm

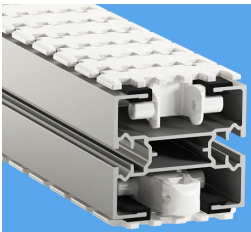

Features

Suitable for a wide range of applications. Includes components for pallet handling (X85P) and vertical wedge conveyors.

Examples of application areas

Home care products, personal care products, pucks for filling operations, secondary packages, cartons.

Technical characteristics

Beam width	85 mm
Chain width	83 mm
Chain pitch.....	33,5 mm
Drive unit capacity	300–1250 N
Chain tension limit	1250 N
Item width	20–200 mm
Maximum:	
conveyor length.....	30 m
weight on conveyor	200 kg
load per 100 mm conveyor length.....	75 N
item weight, horizontal transport	15 kg
item weight, vertical transport	10 kg

Vertical wedge conveyor applications

Item width	40–300 mm
Maximum:	
conveyor length.....	8 m
item weight.....	2 kg
permitted load per link	2,5 kg

Conveyor modules

Straight conveyor

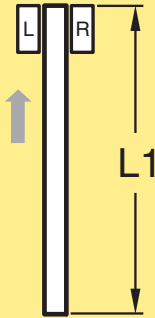

Conveyor module – straight * **5990226**

**Use online configurator when ordering*

One bend conveyor

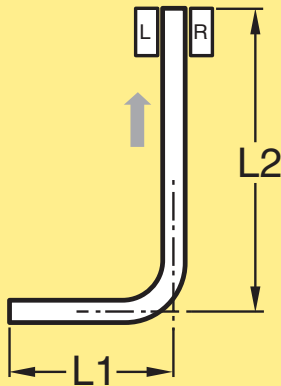

Conveyor module – one bend * **5990230**

**Use online configurator when ordering*



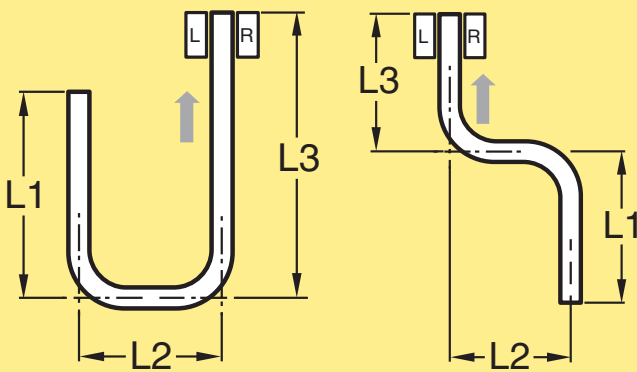











Two bend conveyor



Conveyor module – two bends * **5990237**

**Use online configurator when ordering*

Support modules – single and multi-lane

	5995387	Single diecast
	5995388	Single end adjustable
	5995389	Single end guide roller
	5995390	Single foot plate
	5995391	Single two/three-point
	5995393	Multi single 2 lane
	5995394	Multi single 3 lane
	5995395	Multi single 4 lane
	5995396	Multi double 2 lane
	5995397	Multi double 3 lane
	5995398	Multi double 4 lane
	5995400	Drive unit end
	5995401	Drive unit inline transfer
	5995402	Drive unit wheel bend

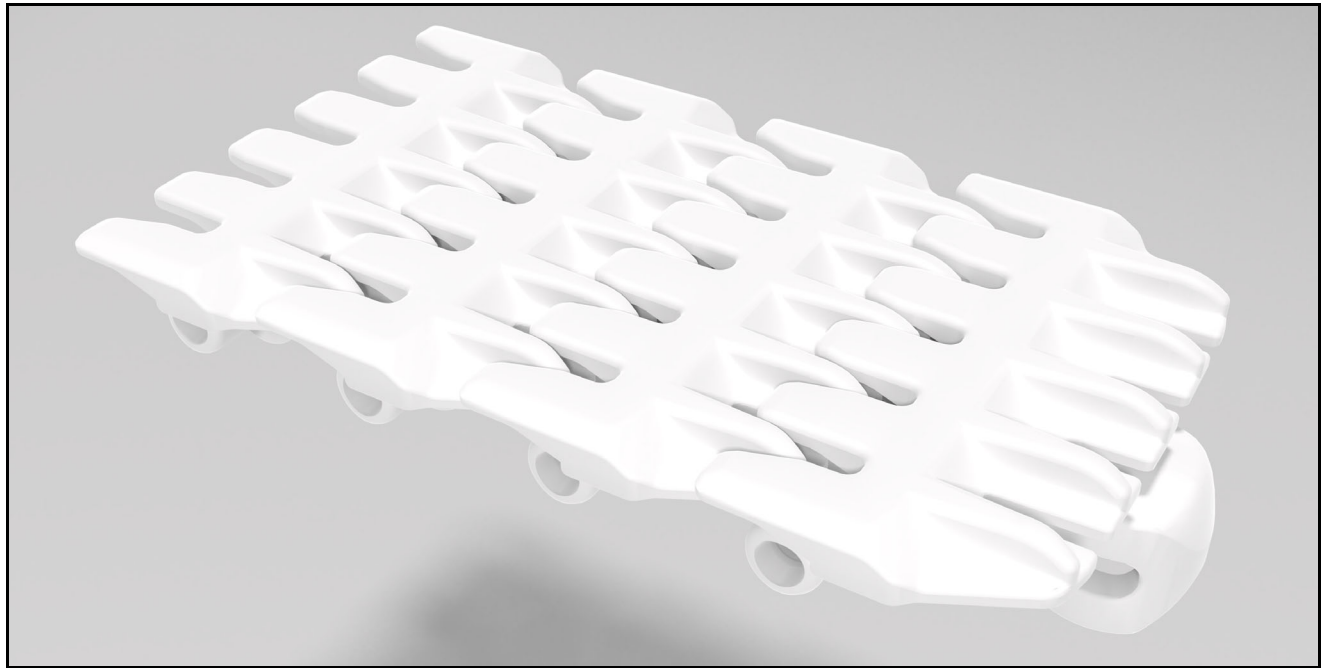

Chain types

The conveyor chain is designed for smooth running, minimum wear and low noise level at normal speeds. For wet applications use XBTPX 5A85.

Chain performance levels

- For most applications: standard chain, available as plain chain, cleated chain, friction top chain, steelp-lated chain, and roller top chain.
- For special applications: ultra high wear resistance chain, steel top chain, high temperature chain, conductive chain, semi-conductive chain, smooth top chain, and wedge top chain.

Note

In pallet systems where pallets type BR or R are used, it is necessary to use the plain chain with closed top XBTP 5A85 K. This will ensure that the pallet surface is at the correct height with regard to other system components. Do not use this chain with other pallet types. See catalogue section “X85 pallet system” for more information.

Configuration of cleated chains

Cleated X85 chains must be ordered using the online configurator. Specify the desired distance between cleats. This means the minimum desired c-c distance between the cleated links. Ensure that enough clearance is provided in relation to the shape of the cleats. See the example below.

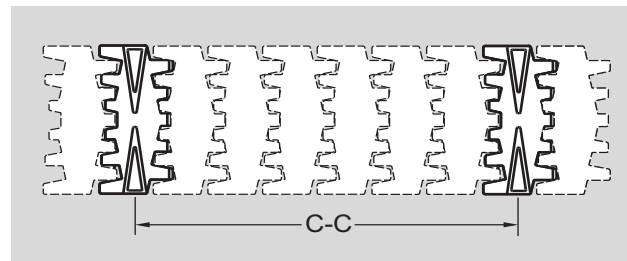

Note

You cannot order cleated chains by specifying the designation given in the catalogue (for example XBTP 5A85X15 K). It is necessary to use the online configurator.

PO

CC

X45

XS

X65

X65P

X85

X85P

XH

XK

XKP

X180

X300

GR

CS

XT

HU

WL

WK

XC

XF

XD

ELV

SC

FST

TR

APX

IDX

Chains

Plain chain

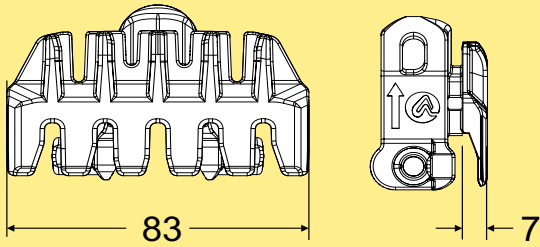

Plain chain
Length 5 m
Standard material
Food & Wet applications

XBTP 5A85 K
XBTPX 5A85K

Plain link kit *
Standard material
Food & Wet applications

FLX1003436
FLX1003437

*Link kit contains 10 links, 10 pivots, 10 steel pins
Use this chain in pallet systems with pallets type BR or R. Not suitable for other pallet types.

Friction top chain

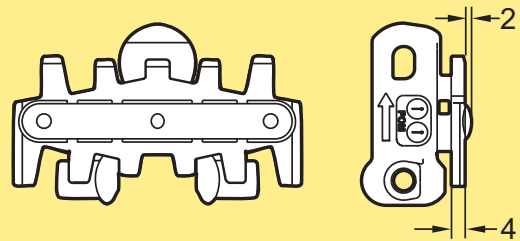

Friction top chain
Length 5 m
All links are friction type
Every 2nd link is friction type

XBTP 5A85 F
XBTP 5A85 F2

Friction top link kit *

5110518

*Link kit contains 10 friction top links, 10 pivots, 10 steel pins

Plain chain

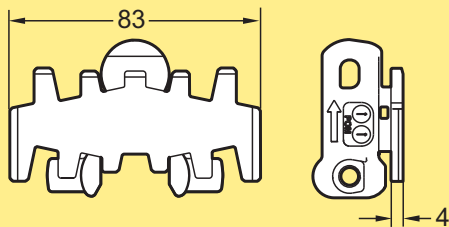

Plain chain
Length 5 m
Standard material
Conductive material
Ultra low wear
Food & Wet applications

XBTP 5A85
XBTP 5A85 E
XBTP 5A85 C
XBTPX 5A85

Plain link kit *
Standard material
Conductive material
Ultra low wear
Food & Wet applications

5110529
5110527
5110533
5110512

*Link kit contains 10 links, 10 pivots, 10 steel pins
Do not use this chain with pallets type BR or R.

Flat friction top chain

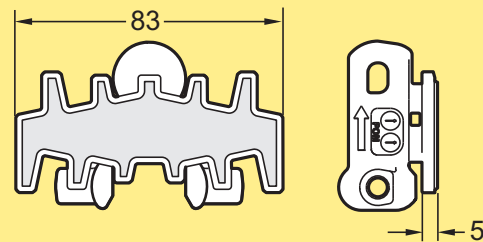

Flat friction top chain
Length 5 m

XBTP 5A85 FA

Friction top link kit *

5110528

* Link kit contains 10 links, 10 pivots, 10 steel pins

Steel top chain

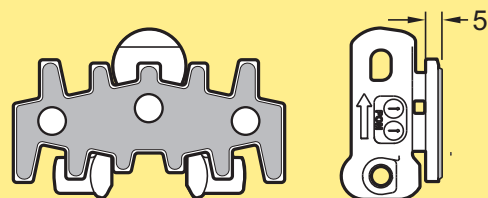

Steel top chain
Length 5 m

XBTP 5A85 TF

Steel top link kit *

5110519

*Link kit contains 10 links, 10 pivots, 10 steel pins
Top part has steel cover for improved wear resistance.

Cleated chain, Type A

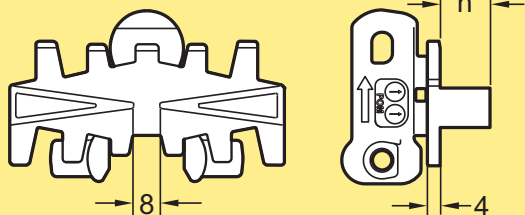

Cleated chain
Type A cleats
Length 5 m
h=15 mm
h=30 mm

XBTF 5A85×15 A
XBTF 5A85×30 A

** This product is delivered with plain links between the cleats. Use the online configurator to specify and order.*

Cleated link kit **
h=15 mm
h=30 mm

5110516
5110517

*** Link kit contains 10 links, 10 pivots, 10 steel pins*

Roller top chain

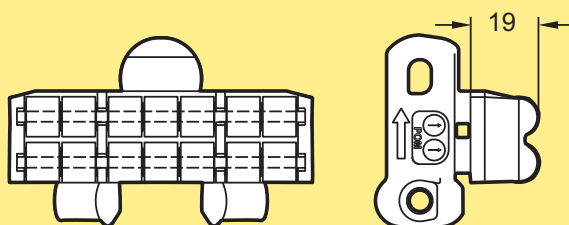

Roller top chain
Length 5 m

XBTR 5A85 P

Use the online configurator to specify and order.

Roller top chain
Length 5 m

XBTR 5A85

Roller top link kit *

5110520

** Link kit contains 10 links, 10 pivots, 10 steel pins*

Chain with 23 mm roller cleats

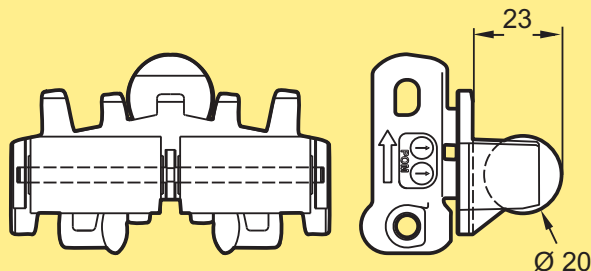

Chain with 23 mm roller cleats *
Length 5 m

XBTF 5A85×23 R

** This product is delivered with plain links between the cleats. Use the online configurator to specify and order.*

Roller cleat link kit

5110521

*** Link kit contains 10 links, 10 pivots, 10 steel pins*

Chain with 46 mm roller cleats

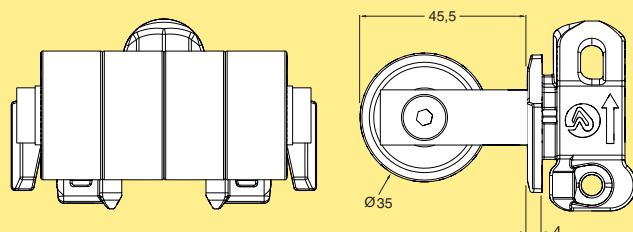

Chain with roller cleats *
Length 5 m

XBTF 5A85×46 R

** This product is delivered with plain links between the cleats. Use the online configurator to specify and order. Note. This chain requires minimum one plain link between every cleated link.*

Roller cleat link kit **

5110583

*** Link kit contains 1 link, 1 pivot, 1 steel pin*

Flexible cleat chain, Type B

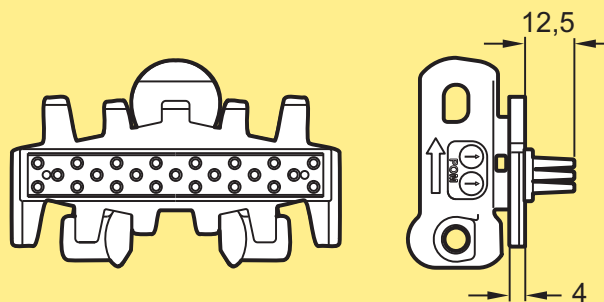

Flexible cleat chain Type B
Length 5 m

XBTE 5A85 B

** This product is delivered with plain links between the cleats.*

Flexible cleat link kit

5110522

*** Link kit contains 10 links, 10 pivots, 10 steel pins*

Flexible cleat chain, Type C

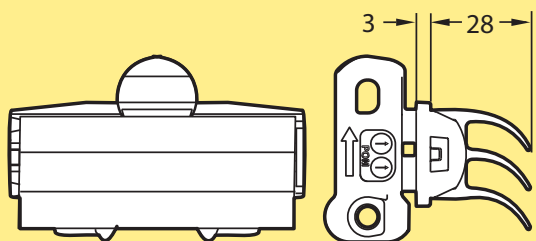

Flexible cleat chain Type C
Length 5 m

XBTE 5A85 C

Flexible cleat link kit *(link base and flexible cleat top)

5110363

Flexible cleat top kit (replacement)

5110515

*Link kit contains 10 links, 10 pivots, 10 steel pins

**Cleat kit contains 10 flexible cleat tops

Flexible cleat chain, Type D

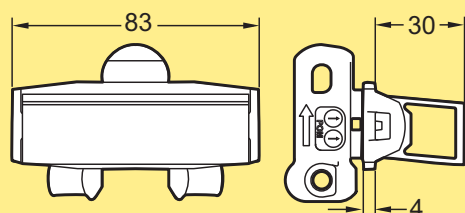

Flexible cleat chain Type D
Length 5 m

XBTE 5A85 D

Flexible cleat link assembly Type D*
(link base and flexible cleat top)

5110582

Flexible cleat top (replacement)

5056311

*Link kit contains 10 links, 10 pivots, 10 steel pins

**Cleat kit contains 10 flexible cleat tops

Universal chain

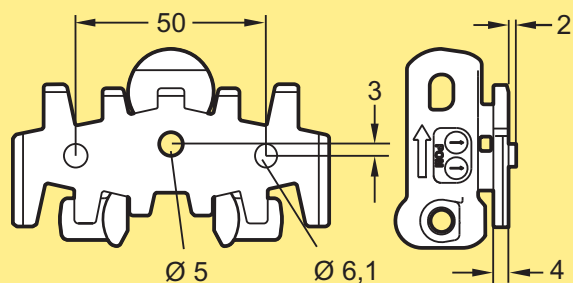

Universal chain*
Length 5 m

XBTF 5A85 U

*This product is delivered with plain links between the universal links. Use the online configurator to specify and order.

The link has a hole for an M5 screw. An M5 nut will fit inside the link.

Universal link kit **

5110526

**Link kit contains 10 links, 10 pivots, 10 steel pins

V-block chain

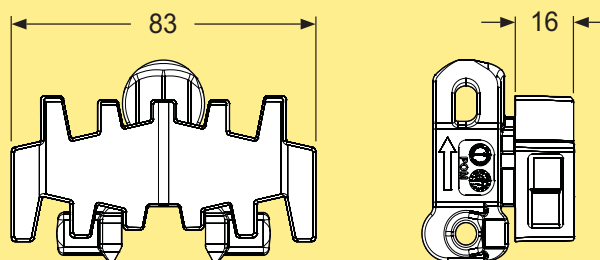

V-block chain
Length 5 m

5110386

V-block chain kit *

5110577

* Link kit contains 10 links, 10 pivots, 10 steel pins

Steel chain, X85

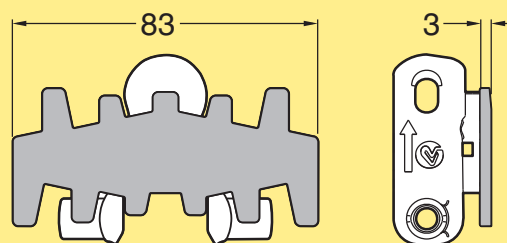

Steel chain X85
Length 5 m

5056849

Steel link X85 (spare part, 10 pcs)
Including pins and pivots.

5058301

Entire top part is electro-zinc-plated hardened steel (700HV1). Bottom part is acetal resin.
Rebuilding instructions are included see page 532.
Modification kits are available. See page 167.

Other chains

See the *Chain guide* for a selection of other chains.

Chain installation

See "Appendix "D. Chain installation" on page 530 for installation instructions.

Chain accessories

Plastic pivot for chain

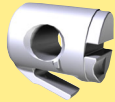

Plastic pivot kit

5111169

Spare parts kit, 25 pcs

Steel pin for chain

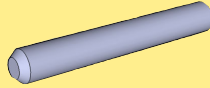

Steel pin kit

5111172

Spare parts kit, 25 pcs

Pin insertion tool for chain

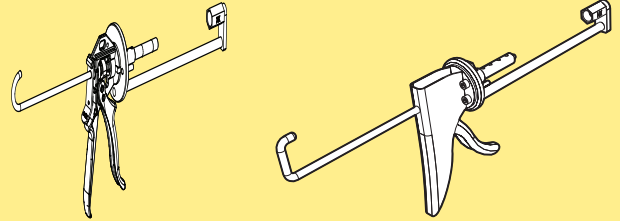

Pin insertion tool

X85-X180/X300

X85-X180/X300-XH, PRO version*

XMMJ 6

XBMJ 6 P

**This tool is recommended for frequent users*

Accessories for use with steel chain 5056849

Rebuilding kit for end drive unit

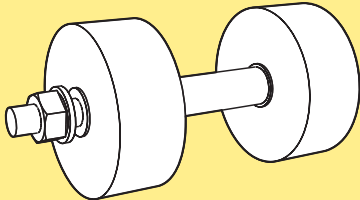

Rebuilding kit for End drive unit H **5058263**

Kit includes support rolls for guidance of chain under the drive unit. Rebuilding instructions are delivered with the chain.

Note. Can only be used for chains without cleats or rollers.

Rebuilding kit for direct drive

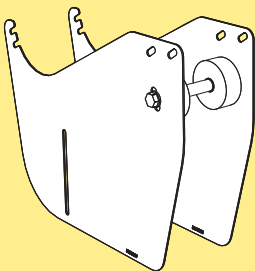

Rebuilding kit for End drive unit H, direct drive

5058269

Kit includes support rolls for guidance of chain under the drive unit, and side plates for replacement. Rebuilding instructions are delivered with the chain.

PO

CC

X45

XS

X65

X65P

X85

X85P

XH

XK

XKP

X180

X300

GR

CS

XT

HU

WL

WK

XC

XF

XD

ELV

SC

FST

TR

APX

IDX



Beam design

The X85 beams are designed for rigidity, smooth running, high speeds and low noise. Features include a flat top surface and heavy duty T-slots. The T-slots ensure easy but rigid attachment of accessories such as guide rail brackets.

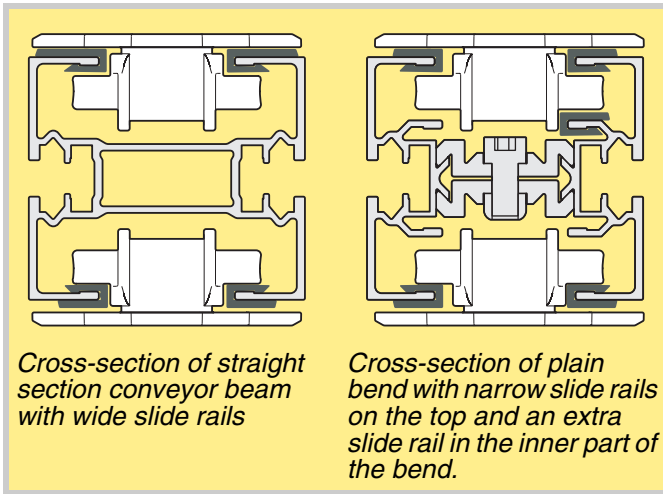

Slide rail

The slide rails are designed for long service life, smooth running, low elongation and minimized risk of failure. They feature increased wear surface thickness. Several options exist for high performance operation. Slide rail types include

- Standard
- Type U – low friction
- Type P – high resistance to chemicals
- Type H – high wear resistance
- Steel for ultra high wear resistance
- ESD – conductive – dissipative for applications sensitive to static electricity

Very high speeds: see *Engineering guidelines* or contact FlexLink Systems for more information.

Three slide rail profiles

Slide rails are available in three profile designs: standard, wide, and wide with guidance.

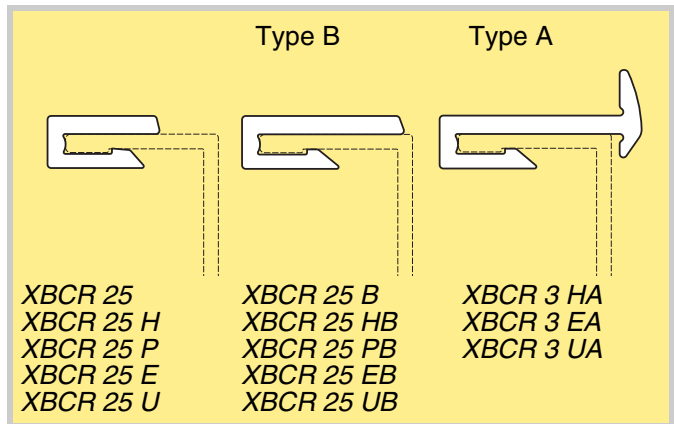

Normally the wide slide rail (type B) is used. For light loads, and in bends, the narrow width slide rail is suitable. The slide rail with a side flange (type A) improves appearance and protection.

Slide rails in bends

Special instructions apply for installation of plastic slide rail in bends. Such instructions are included with the delivery. The wide slide rails (type A and B) are not suitable for use in bends.

Slide rail in hardened steel

Slide rails in hardened steel are used in applications where abrasive particles occur. Such slide rails cannot be bent, and are attached on the top of the conveyor beam using brass or stainless steel rivets. Pre-bent sections for wheel bends are available. See appendix B for installation instructions.

Conveyor beam

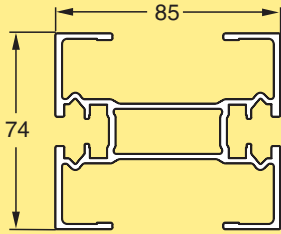

Beam
 Length 3000 +10/-0 mm
 Length to order (30- 3000 mm)

XBCB 3A85
XBCB LA85

Slide rail: see page 170.
 Beam accessories: see below.

Beam section for chain installation

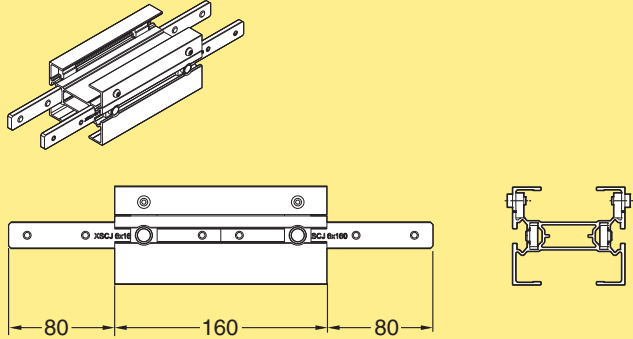

Beam section kit
 Including connection strips and screws

XBCC 85x160 A

Profile for split conveyor beam

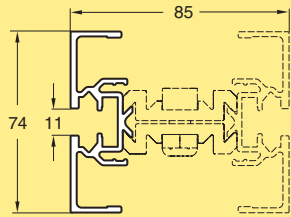

Profile for split conveyor beam
 Length 3000 +10/-0 mm
 Length to order (30- 3000 mm)

XBCB 3A85 H
XBCB LA85 H

Beam clip assembly

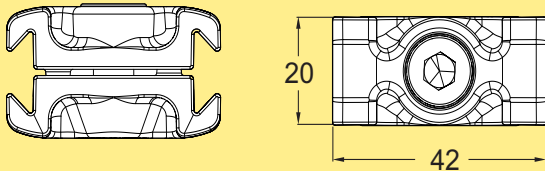

Beam clip assembly
 Including M8 screw and locking nut. Use minimum 5 clips per meter. Place clips 100 mm from each end. Note. Contains 10 pcs..

XBCE 42x20 A

Beam accessories

Connecting strip with set screws

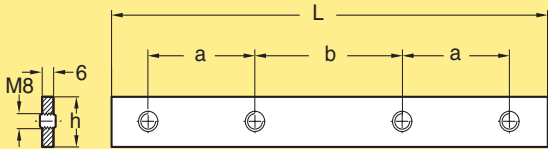

Connecting strip with set screws
 h=20, a=30, b=50, L=130
 h=20, a=44, b=44, L=160

XSCJ 6x130
XSCJ 6x160

Note. Contains 10 pcs.

Cover strip for T-slot, PVC

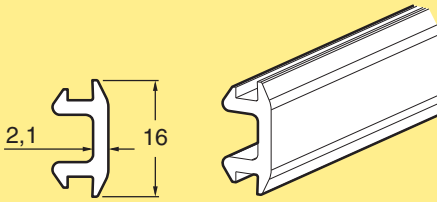

Cover strip for T-slot
 Length 25 m
 Grey PVC

XCAC 25 P

Cover strip for T-slot, PVC

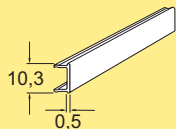

Cover strip for T-slot
 Length 3 m
 Grey PVC

XCAC 3 P

Note! Can't be used with bends

Cover strip for T-slot, aluminium

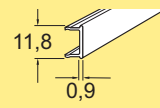

Cover strip for T-slot
 Aluminium, anodized
 Length 2 m

XCAC 2

Note! Can't be used with bends

Beam accessories (continued)

Beam spacer

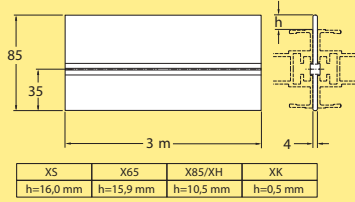

Beam spacer

Aluminium, anodized
Length 3 m

XLCD 3

For connection of two conveyor beams side to side. Use M8 screw and slot nut. Two holes must be drilled, one through the spacer (9 mm) and one through the beam, to allow insertion of the screw. The diameter of the second hole depends on the size of the screw head.

Articulated beam section

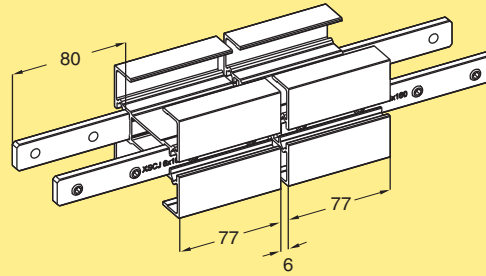

Articulated beam section vertical **XBCH 5A85 V**

Slide rails

Plastic slide rails, narrow

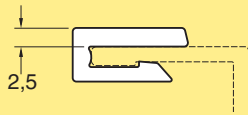

Slide rail

Length 25 m

HDPE (Black)

PA-PE (Grey)

PVDF (Natural white)

PE-UHMW (White)

PE-UHMW (Blue)

PE-UHMW conductive (Black)

XBCR 25

XBCR 25 H

XBCR 25 P

XBCR 25 U

XBCR 25 UL A

XBCR 25 E

Plastic slide rails, wide with guidance

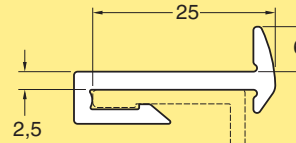

Slide rail

Length 3 m

PA-PE (Grey)

PE-UHMW (White)

PE-UHMW conductive (Black)

XBCR 3 HA

XBCR 3 UA

XBCR 3 EA

Note. The wide slide rails are not suitable for use in bends.

Plastic slide rails, wide

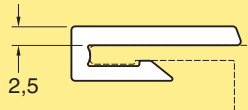

Slide rail

Length 25 m

HDPE (Black)

PA-PE (Grey)

PVDF (Natural white)

PE-UHMW (White)

PE-UHMW conductive (Black)

XBCR 25 B

XBCR 25 HB

XBCR 25 PB

XBCR 25 UB

XBCR 25 EB

Note. The wide slide rails are not suitable for use in bends.

Aluminium rivets for anchoring of slide rail

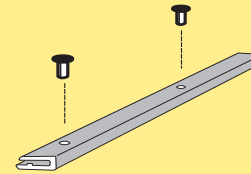

Aluminium rivets 4 mm for XK-
X180/X300 conveyors, brown

XLAH 4x7

Extra slide rail in plain bends must be anchored using plastic screws due to lack of space for the rivet crimping tool.

Note. Contains 250 pcs..

Plastic screws for anchoring of slide rail

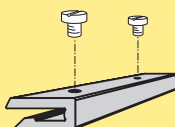

Plastic screws 5 mm **XLAG 5**

Only intended for use with low slide rail in plain bends. Extra slide rail in plain bends must be anchored using plastic screws due to lack of space for the rivet crimping tool.

Note. Contains 50 pcs.

See mounting instruction "Anchoring slide rail using plastic screws" on page 526

Drill fixture for slide rail

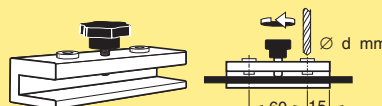

Drill fixture for slide rail
d=4,2 mm **3920500**

Rivet crimping pliers



Rivet crimping pliers
For 4 mm rivets **5051395**

Toolbox for assembly and maintenance (X85, XH)

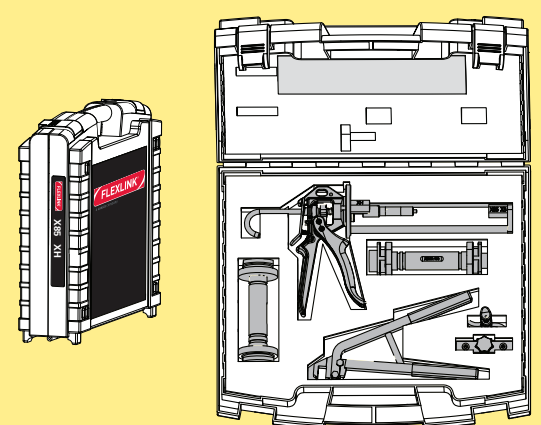

Toolbox **FLX1007288**

Contains:

Pin insertion tool (chain)	XBMJ 6 P
Mounting tool (X85)(slide rail)	XBMR 170
Mounting tool (XH) (slide rail)	XHMR 200
Rivet crimping pliers 4 mm (slide rail)	5051395
Rivet crimping clamp 4 mm (slide rail)	3923005
Drill fixture 4 mm (slide rail)	3920500

Rivet crimping clamp

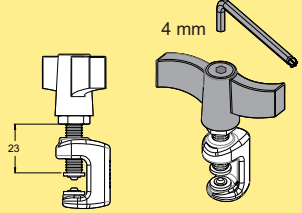

Rivet crimping clamp
For 4 mm rivets
(Allen key not included) **3923005**

Mounting tool for slide rail

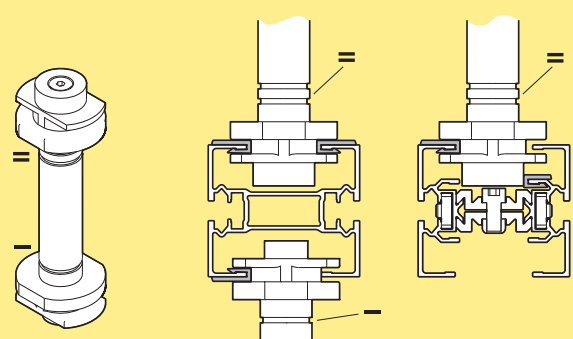

Mounting tool for slide rail **XBMR 170**

Slide rail in hardened steel

Steel slide rail, straight

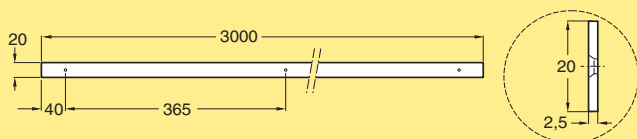

Slide rail, hardened steel
Length 3 m

XBCR 3 TH

Delivered with 9 predrilled holes

Steel slide rail for wheel bends

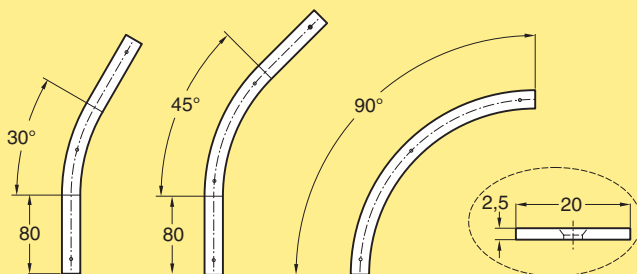

Slide rail for bends, hardened steel

Slide rail for bend, 30°

Slide rail for bend, 45°

Slide rail for bend, 90° & 180°

XBCR W30 TH

XBCR W45 TH

XBCR W90 TH

180°: Use 2 pieces of steel slide rail 90°

Brass rivets

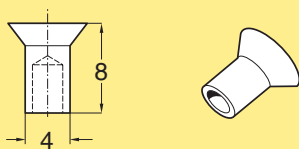

Brass rivets (100 pcs)

5056167

Rivets for anchoring the slide rails

Stainless steel rivets

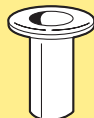

Stainless steel rivet, 4 mm

XLAHX 4x6

Rivet for anchoring the slide rails. Contains 10 pcs.0.

Note. Do not use in applications where metal chips might get stuck in the hole in the rivet.

Cover strip

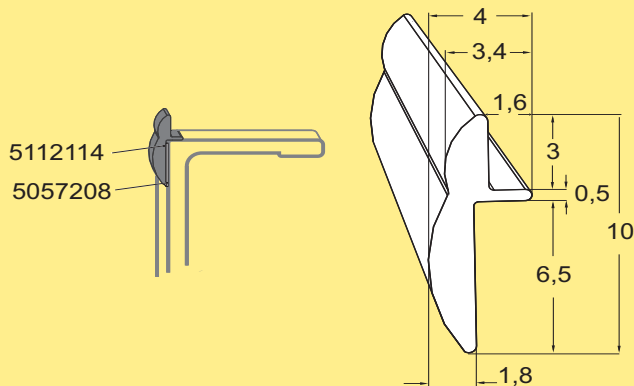

Cover strip

Length: 3 m

Material: Plastic PA 12

5112114

Cover the opening on the side between the chain and beam. Primarily for straight sections and the outer curves, but can also be mounted on inner curves. Apply using Glue tape 5057208, see mounting instruction 5497EN in Technical library.

Glue tape 3M



Glue tape

Length 30 m

5057208

Drive unit types

The X85 system includes Compact (C), Medium (M), and Heavy (H) drive units. Drive unit capacities range from maximum 1250 N for the H types down to maximum 300 N for the C types. The actual capacity depends on the speed and type of drive unit.

Several configurations are available, including direct driven units with or without slip clutch. Heavy duty drives with suspended motor and transmission chain can also be ordered.

Available motors include variable speed types (V) as well as fixed speed motors (F).

End drive units

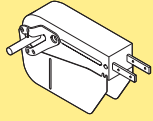
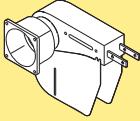
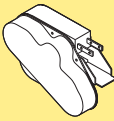
Size	Direct drive, no slip clutch	Direct drive, slip clutch	Suspended motor, transmission chain, slip clutch
			
Compact	F	–	–
Medium	F, V	–	–
Heavy	F, V	F, V	F
Heavy, guided	F, V	F, V	–

Intermediate drive units

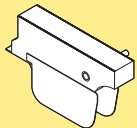
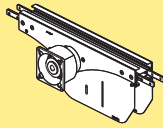
Size	Direct drive, no slip clutch	Direct drive, slip clutch
		
Medium	F, V	F, V

Wheel bend drive units

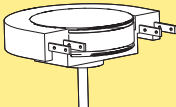
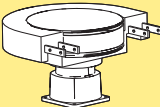
Size	Direct drive, no slip clutch	Direct drive, slip clutch
		
Heavy	F, V	F, V

Double drive units

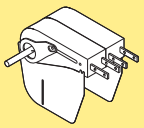
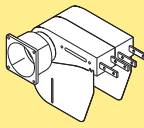
Size	Direct drive, no slip clutch	Direct drive, slip clutch
		
Heavy	F, V	F, V

End drive unit, guided chain

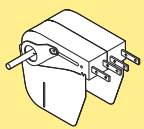
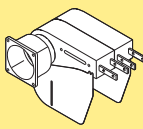
Size	Direct drive, no slip clutch	Direct drive, slip clutch
		
Heavy	F, V	F, V

Motor specifications

Motors are available for 230/400 V, 50 Hz and 230/460 V, 60 Hz. Variable speed motors are SEW Movimot, 380–500 V. Note that variable speed motors include a control box that adds 120 mm to the width of the motor.

IP55 available with standard oil.

IP65 available with food grade oil.

Idler unit types

Idler units are available in two versions, Compact and Heavy.

Ordering information

Drive units with motors must be specified using the web-based configurator. The configurator provides detailed information and step-by-step guidance in the specification process. A product code string is generated, containing the specification details. See next page for examples of code strings.

Drive units *without* motors can be ordered using the designations in the catalogue.

Dimension

Note that dimensions relating to drive unit motors depend on the motor specified during the configuration.

Dimension limits – in-line transfer drive units (X-bends)

The dimensions of an in-line drive unit impose restrictions with regard to conveyor geometry. The idler part of the drive unit may interfere with other parts of the conveyor. The figure shows a typical case, showing typical minimum dimensions.

Also note the special support arrangements for in-line transfer units. See page 181.

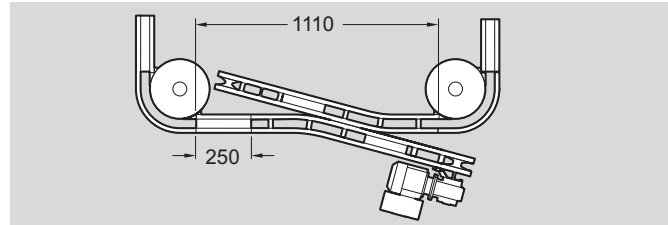

PO
CC
X45
XS
X65
X65P
X85
X85P
XH
XK
XKP
X180
X300
GR
CS
XT
HU
WL
WK
XC
XF
XD
ELV
SC
FST
TR
APX
IDX

End drive unit H, suspended motor, slip clutch

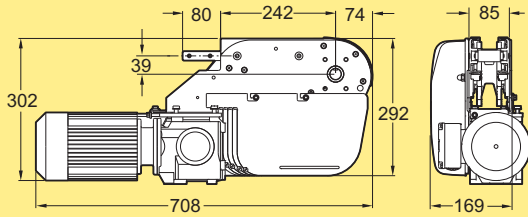

End drive unit

Suspended 3-phase motor. Adjustable slip clutch.
Maximum traction force: up to 1250 N.
Fixed speeds up to 60 m/min.

Transmission on left side:

Fixed speed * **XBEB A85**
Without motor (ISO) **XBEB 0A85HL**
Without motor (ANSI) **XBEB 0A85HLA**

Transmission on right side (not shown):

Fixed speed * **XBEB A85**
Without motor (ISO) **XBEB 0A85HR**
Without motor (ANSI) **XBEB 0A85HRA**

*Use online configurator when ordering.

Effective track length: 0,80 m

End drive unit H, direct drive, no slip clutch

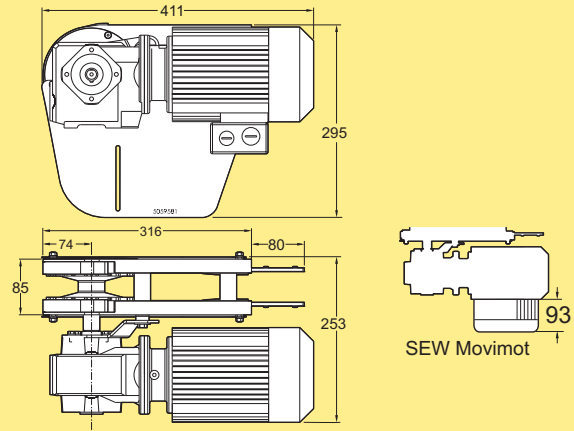

End drive unit

Direct drive. No slip clutch.
Maximum traction force: up to 1250 N.
Fixed speeds up to 60 m/min.
Variable speed up to 120 m/min.

Motor on left side:

Fixed/variable speed * **XBEB A85**
Without motor **XBEB 0A85HNLP**

Motor on right side (not shown):

Fixed/variable speed * **XBEB A85**
Without motor **XBEB 0A85HNRP**

*Use online configurator when ordering.

Effective track length: 0,80 m

End drive unit H, direct drive, slip clutch

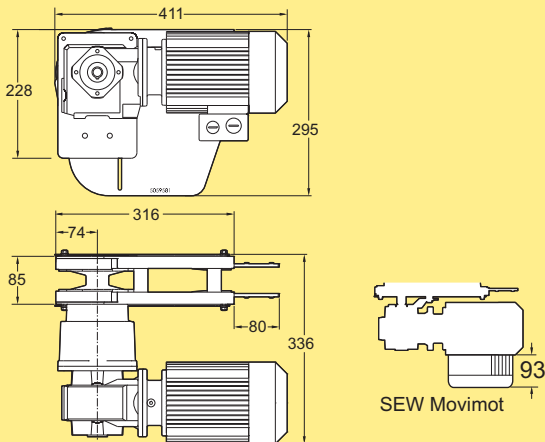

End drive unit

Direct drive. Adjustable slip clutch.
Maximum traction force: up to 1250 N.
Fixed speeds up to 60 m/min.
Variable speed up to 120 m/min.

Motor on left side:

Fixed/variable speed * **XBEB A85**
Without motor **XBEB 0A85HLP**

Motor on right side (not shown):

Fixed/variable speed * **XBEB A85**
Without motor **XBEB 0A85HRP**

*Use online configurator when ordering.

Effective track length: 0,80 m

Support bracket for HNLP/HNRP drive units

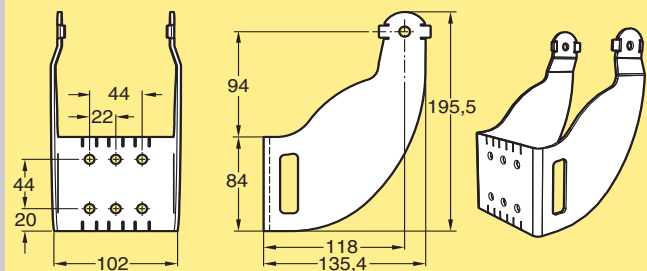
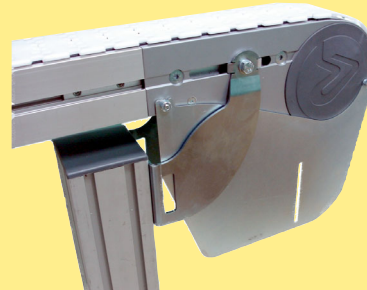

Support bracket kit

5111370

Including screw kit: 6 each of M6S M8×12, BRB 8.4×16, XCAN 8.

End drive unit M, direct drive, no slip clutch

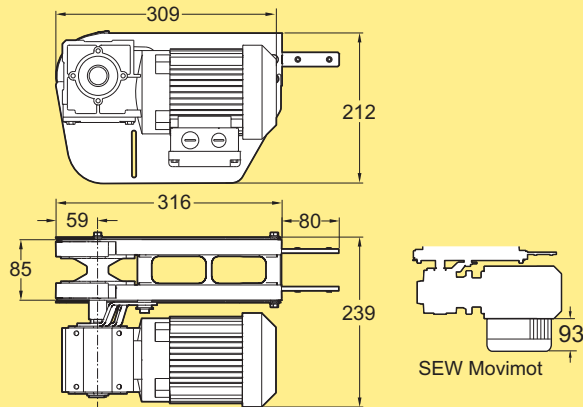

End drive unit

Direct drive. No slip clutch.
 Maximum traction force: up to 800 N.
 Fixed speeds up to 60 m/min.
 Variable speed up to 60 m/min.

Motor on left side:

Fixed/variable speed * **XBEB A85**
 Without motor **XBEB 0A85MNL P**

Motor on right side (not shown):

Fixed/variable speed * **XBEB A85**
 Without motor **XBEB 0A85MNR P**

* Use online configurator when ordering.

Effective track length: 0,70 m

End drive unit C, direct drive, no slip clutch

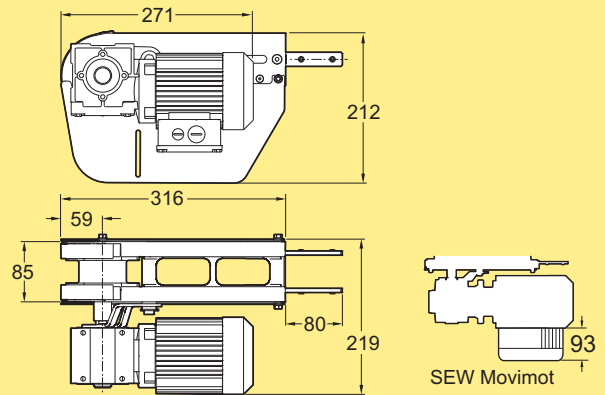

End drive unit

Direct drive. No slip clutch.
 Maximum traction force: up to 300 N.
 Fixed speeds up to 35 m/min.

Motor on left side:

Fixed speed * **XBEB A85**
 Without motor **XBEB 0A85CNLP**

Motor on right side (not shown):

Fixed speed ' **XBEB A85**
 Without motor **XBEB 0A85CNR P**

*Use online configurator when ordering.
 Note. The motors for Compact drive units cannot be reconfigured from star to delta operation.

Effective track length: 0,70 m

Guide wheel kit



Guide wheel for drive units **5055635**

Including wheel, shaft and mounting hardware.
 Note. Can only be used with plain chain. For use in high speed operation (60 m/min and above) or use for a more quiet operation at lower speed.

Double drive unit H, slip clutch

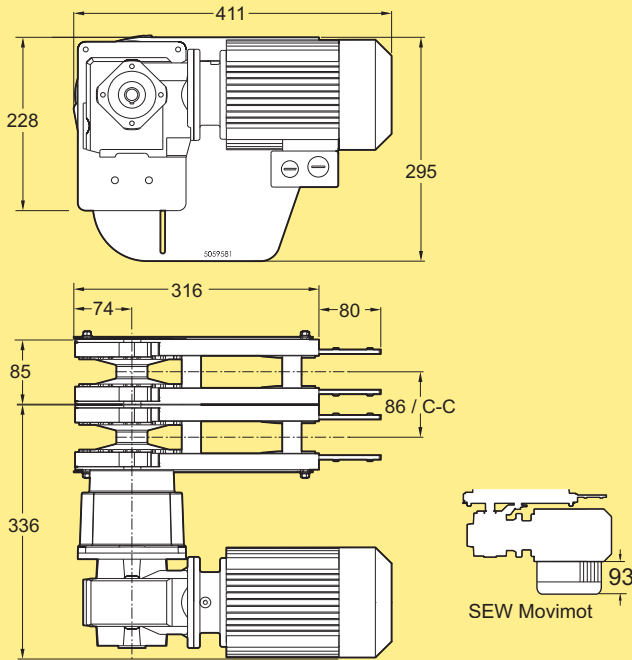

Double drive unit

Direct drive. Adjustable slip clutch.
Maximum traction force: up to 1250 N.
Fixed speeds up to 60 m/min.
Variable speed up to 60 m/min.

Motor on left side:

C-C=86 mm
Fixed/variable speed * **XBEB DD A85**
Without motor **XBEB 0A85HLPD86**

C-C=130–350 mm
Fixed/variable speed * **XBEB DD A85**
Without motor **XBEB 0A85HLPD–****

Motor on right side (not shown):

C-C=86 mm
Fixed/variable speed * **XBEB DD A85**
Without motor **XBEB 0A85HRPD86**

C-C=130–350 mm**
Fixed/variable speed * **XBEB DD A85**
Without motor **XBEB 0A85HRPD–****

*Use online configurator when ordering.

**Specify C-C when ordering.

Drawing shows C-C 86 mm version.

Effective track length: 0,80 m (each track)

Double drive unit H, no slip clutch

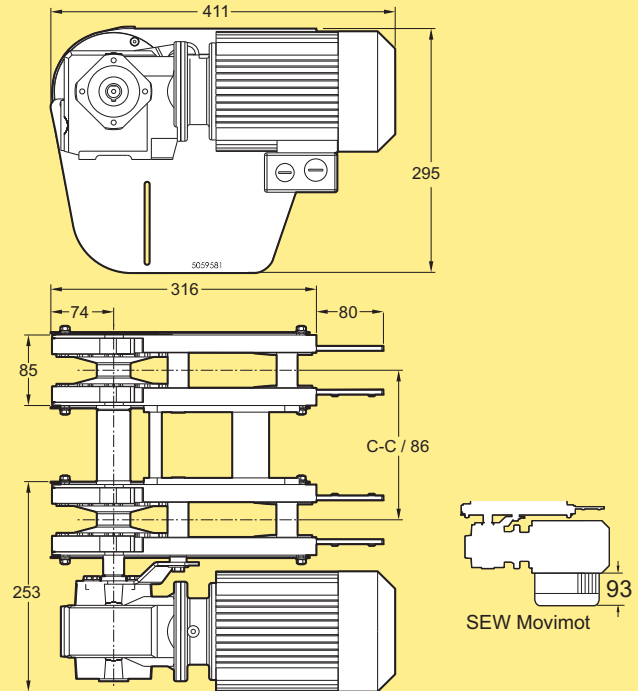

Double drive unit

Direct drive. No slip clutch.
Maximum traction force: up to 1250 N.
Fixed speeds up to 60 m/min.
Variable speed up to 60 m/min.

Motor on left side:

C-C=86 mm
Fixed/variable speed * **XBEB DD A85**
Without motor **XBEB0A85HNLPD86**

C-C=130–350 mm
Fixed/variable speed * **XBEB DD A85**
Without motor **XBEB 0A85HNLPD–****

Motor on right side (not shown):

C-C=86 mm
Fixed/variable speed * **XBEB DD A85**
Without motor **XBEB0A85HNRPD86**

C-C=130–350 mm
Fixed/variable speed * **XBEB DD A85**
Without motor **XBEB 0A85HNRPD–****

*Use online configurator when ordering.

**Specify C-C when ordering.

Drawing shows version with customer specified C-C distance.

Effective track length: 0,80 m (each track)

Wheel bend drive unit, slip clutch

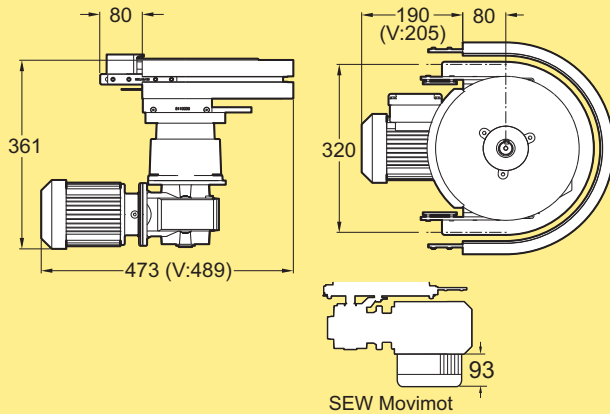

Wheel bend drive unit
 Direct drive. Adjustable slip clutch.
 Maximum traction force: up to 200 N.
 Fixed speeds up to 30 m/min.
 Variable speed up to 30 m/min.

Fixed/variable speed * **XBEW A85**
 Without motor **XBEW 18/0A85HP**

*Use online configurator when ordering.

Maximum conveyor length: 20 m
 Effective track length: 0,65 m

Support adapters for wheel bend drive units

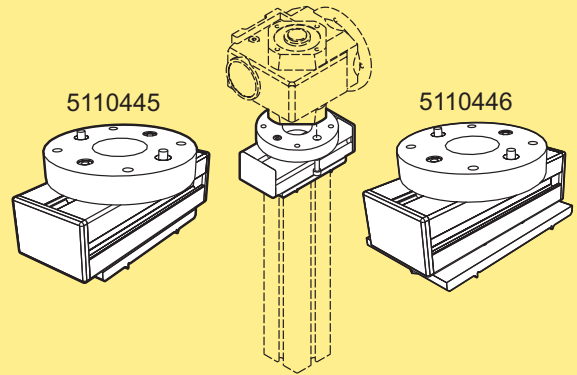

Support adapter for wheel bend drive unit

For support beam XCBM...x64 mm **5110445**
 For support beam XCBM...x88 mm **5110446**

Including mounting hardware and mounting instructions. Note. XCBL support beams cannot be used.

Wheel bend drive unit, no slip clutch

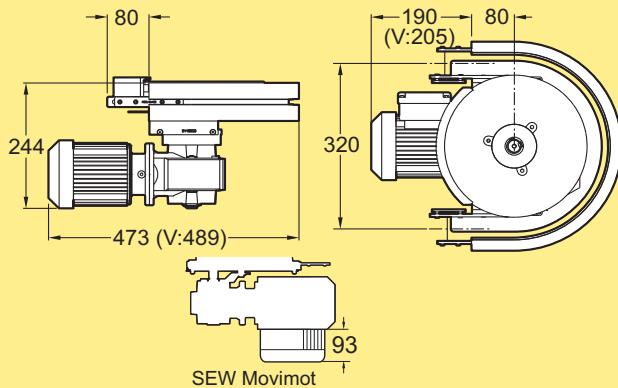

Wheel bend drive unit
 Direct drive. No slip clutch.
 Maximum traction force: up to 200 N.
 Fixed speeds up to 30 m/min.
 Variable speed up to 30 m/min.

Fixed/variable speed * **XBEW A85**
 Without motor **XBEW 18/0A85HNP**

*Use online configurator when ordering.

Maximum conveyor length: 20 m
 Effective track length: 0,65 m

Intermediate drive unit M, no slip clutch

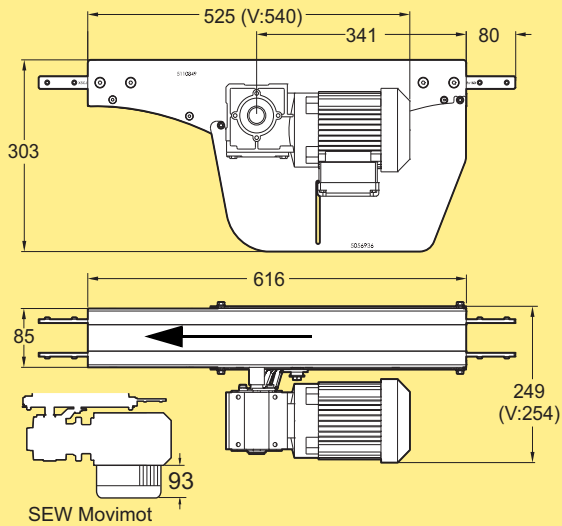

Intermediate drive unit

Direct drive. No slip clutch.

Maximum traction force: up to 200 N.

Fixed speeds up to 25 m/min.

Variable speed up to 25 m/min.

Motor on left side:

Fixed/variable speed *

Without motor

XBER A85

XBER 0A85MNL

Motor on right side (not shown):

Fixed/variable speed *

Without motor

XBER A85

XBER 0A85MNR

**Use online configurator when ordering.*

Effective track length: 1,40 m

Intermediate drive unit M, slip clutch

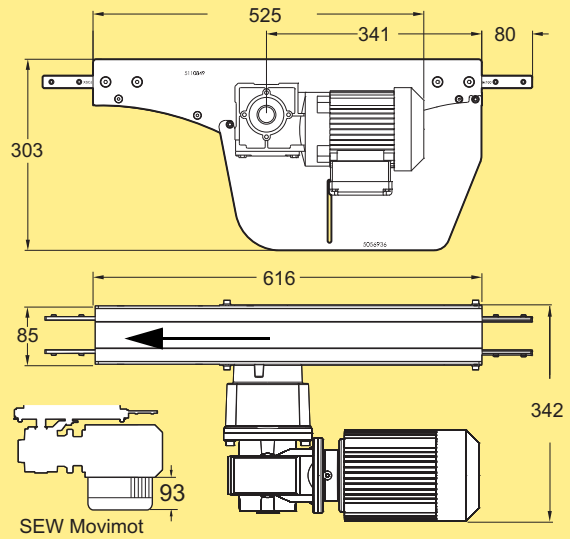

Intermediate drive unit

Direct drive. slip clutch.

Maximum traction force: up to 200 N.

Fixed speeds up to 25 m/min.

Variable speed up to 25 m/min.

Motor on left side:

Fixed/variable speed *

Without motor

XBER A85

XBER 0A85MLP

Motor on right side (not shown):

Fixed/variable speed *

Without motor

XBER A85

XBER 0A85MRP

**Use online configurator when ordering.*

Effective track length: 1,40 m

Intermediate drive unit H, no slip clutch

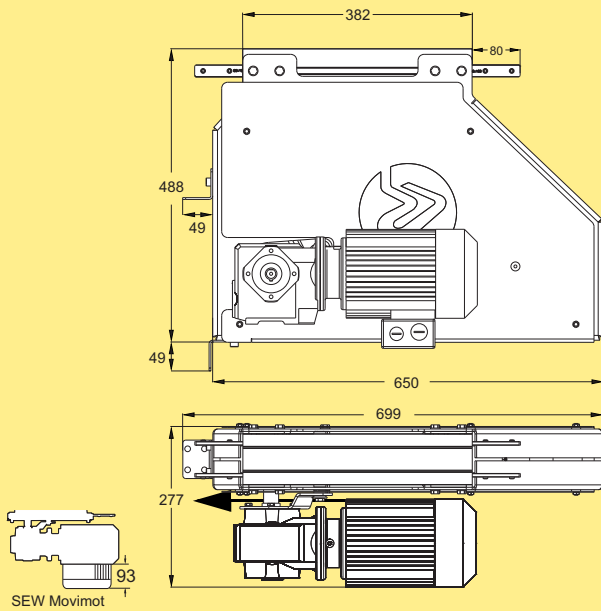

Intermediate drive unit

For standard plain chain only.
 Direct drive. No slip clutch.
 Maximum traction force: up to 875 N.
 Fixed speeds up to 60 m/min.
 Variable speed up to 60 m/min.

Motor on left side:

Fixed/variable speed * **XBER A85**
 Without motor **XBER 0A85HNLP**

Motor on right side (not shown)

Fixed/variable speed **XBER A85**
 Without motor * **XBER 0A85HNRP**

*Use online configurator when ordering

Effective track length: 2,5m

Leg support for Intermediate drive unit H

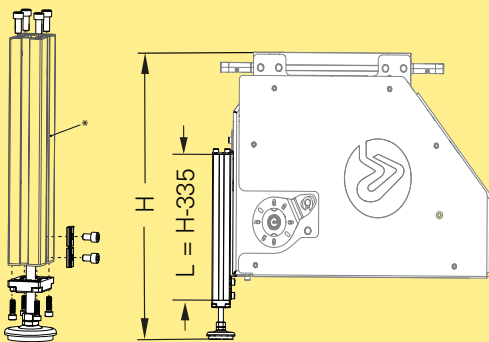

Leg support kit **FLX1008683**

* Note: Beam is not included. Use kit with beam XCBM LX44X64. Min. beam length; 300 mm. Thread top of beam for M8, center threading

End drive unit H, guided chain, slip clutch

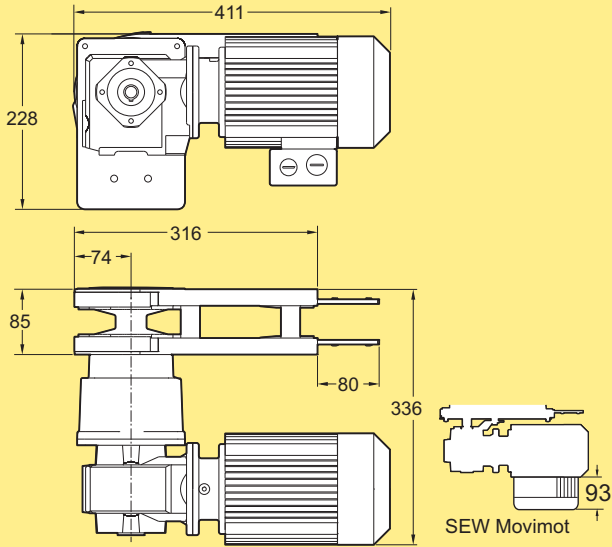

End drive unit

Direct drive with guided chain. Adjustable slip clutch.
 Maximum traction force: up to 1250 N.
 Fixed speeds up to 63 m/min.
 Variable speed up to 63 m/min.

Motor on left side:

Fixed/variable speed * **XBEB A85**
 Without motor **XBEB 0A85HLGP**

Motor on right side (not shown):

Fixed/variable speed * **XBEB A85**
 Without motor **XBEB 0A85HRGP**

**Use online configurator when ordering.*

Effective track length: 0,80 m

End drive unit H, guided chain, no slip clutch

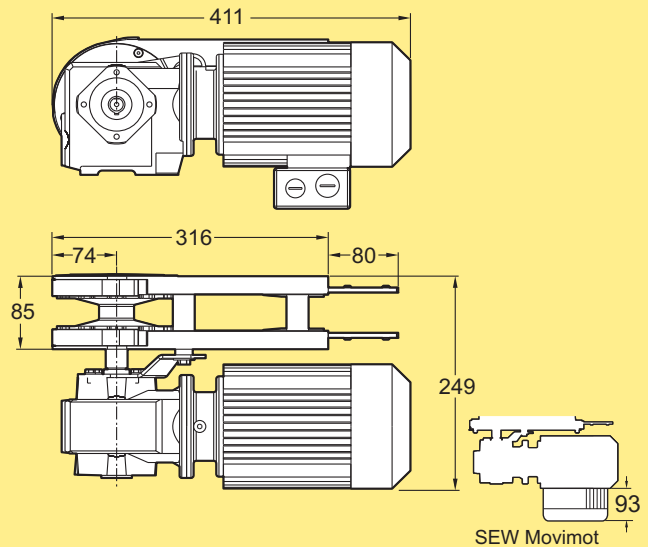

End drive unit

Direct drive with guided chain. No slip clutch.
 Maximum traction force: up to 1250 N.
 Fixed speeds up to 63 m/min.
 Variable speed up to 63 m/min.

Motor on left side:

Fixed/variable speed * **XBEB A85**
 Without motor **XBEB 0A85HNLGP**

Motor on right side (not shown):

Fixed/variable speed * **XBEB A85**
 Without motor **XBEB 0A85HNRGP**

**Use online configurator when ordering.*

Effective track length: 0,80 m

X-bends

X-bend

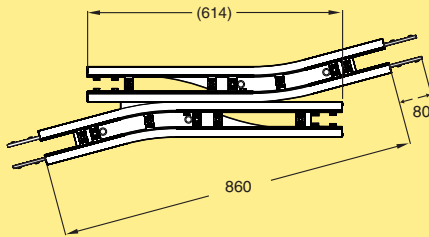
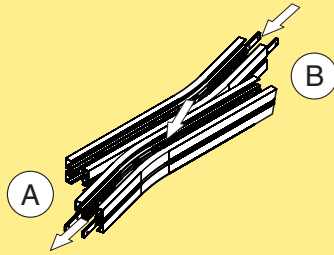

X-bend for top chain

For optional mounting of Idler end unit or Drive unit at the end (A) or (B)

XBCX 85 L

Effective track length: 2,1 m
Note! Include a special arrangement for connecting beam support brackets

X-bend

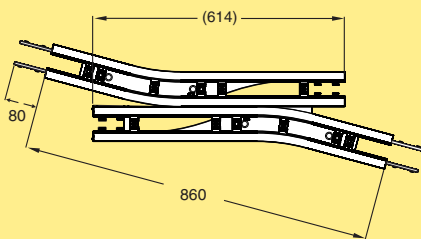
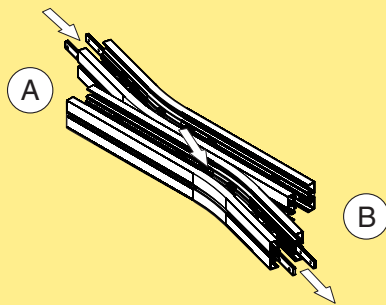

X-bend for top chain

For optional mounting of Idler end unit or Drive unit at the end (A) or (B)

XBCX 85 R

Effective track length: 2,1 m
Note! Include a special arrangement for connecting beam support brackets

Cover plate

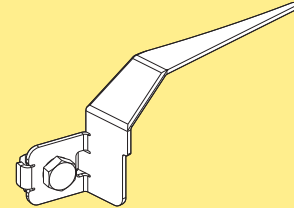

Cover plate

5113482

Note! To avoid pinch points add cover plate in X-bends when using XBTP 5A85 K. Assembly inst. 5113535.

Support components for X-bends

X-bends include a special arrangement for connecting beam support brackets. Instead of connecting the brackets directly to the T-slots in the beams, intermediate U-shaped brackets are used. See figure below.

Support legs to the transfer must be 82,5 mm shorter than other legs connected along the conveyor. Use M6S 8x16 screws instead of XLAT 17 when attaching the beam support bracket to the U-shaped brackets. Read more about beam support brackets on page 335.

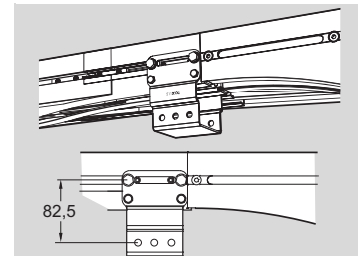

S-Transfer

S-Transfer

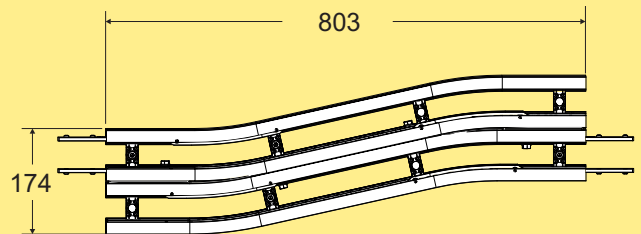

S-transfer for return chain

for X85

XBCY A85 D

Effective track length: 3,2 m

Components for wedge track width adjustment

Note. "Length 3 m" aluminium products are cut to 3000 mm ± 5 mm.

Width adjustment actuator 660 mm

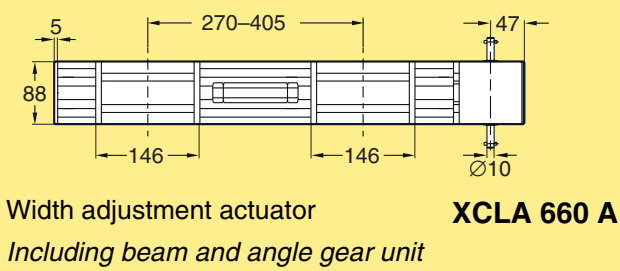
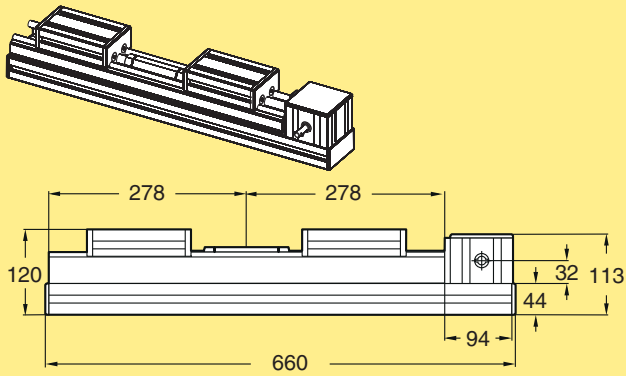

Angle gear unit

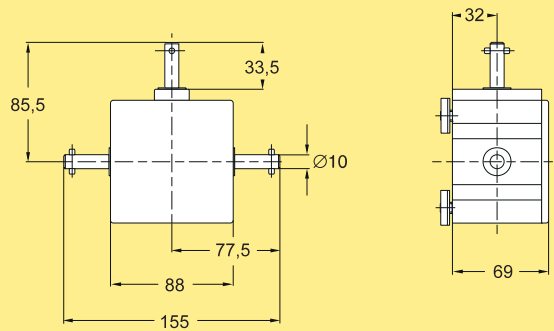

Angle gear unit **XCFW 90**

Shaft

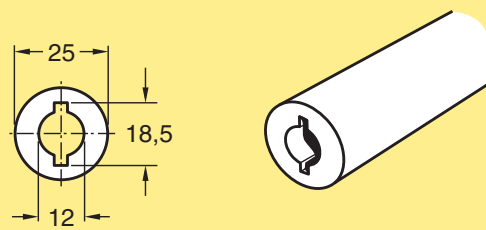

Shaft
Aluminium, anodized
Length 3 m

XLFX 3

The shaft is used to connect angle gear units XCFW 90 to synchronize adjustment of the track width. Use XLAP 28 spring pins to secure the shafts axially.

Width adjustment actuator 950 mm

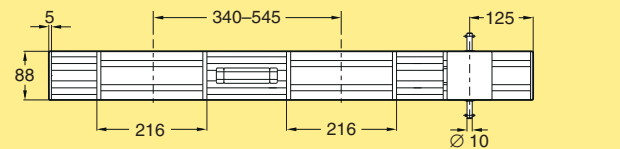
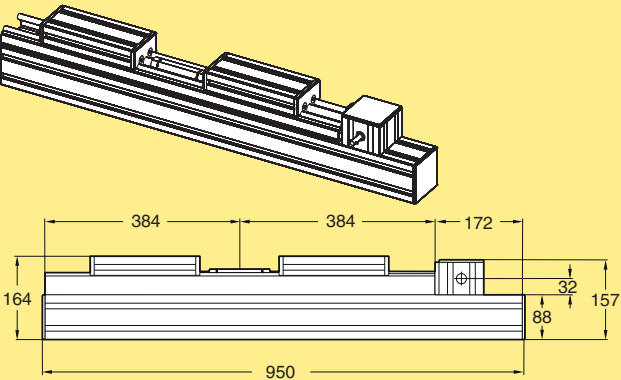

Width adjustment actuator **XCLA 950 A**
Including beam and angle gear unit

Handwheel for 10 mm shaft

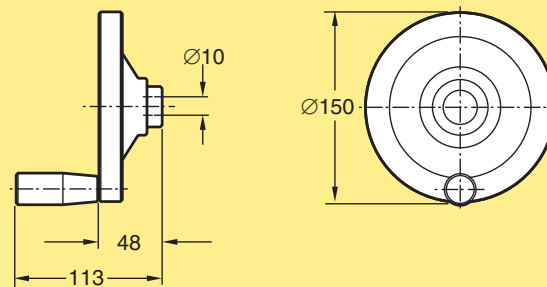

Handwheel for 10 mm shaft **XLAW 160x10**

Idler units

Idler end unit – Heavy

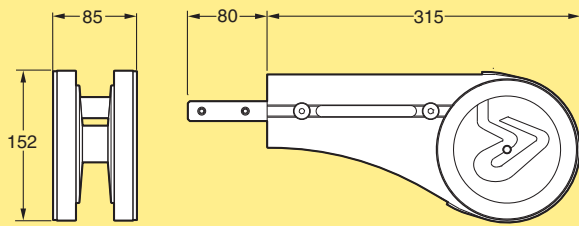

Idler end unit

XBEJ A85

Effective track length: 0,80 m

Idler end unit – Compact

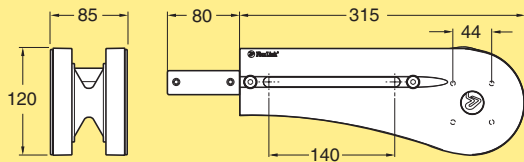

Idler end unit

Compact version

XBEJ A85 S

Effective track length: 0,70 m

Each side plate has T-slots and four unfinished holes for attachment of accessories.

Protective cover for idler end unit H

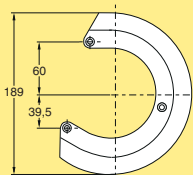

Protective cover for XBEJ A85

XMSJ 189

Suitable for use with standard plain chain and plain chain with closed top.

Protective cover for idler end unit C

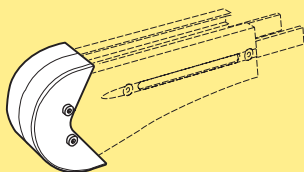

Protective cover for XBEJ A85 S

XMSJ 146

Suitable for use with standard plain chain (Not to be used with XBTP 5A85 A or XBTP 5A85 K).

Including mounting screws (M8).

Idler bend unit, 90°

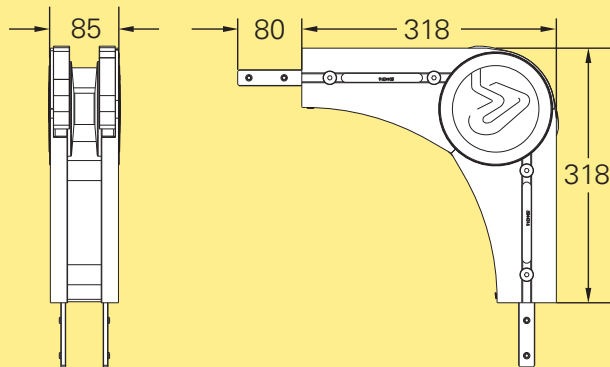

Idler end unit

XBEM 90A85

Effective track length: 0,60 m

Note. Cannot be used with return chain

PO

CC

X45

XS

X65

X65P

X85

X85P

XH

XK

XKP

X180

X300

GR

CS

XT

HU

WL

WK

XC

XF

XD

ELV

SC

FST

TR

APX

IDX

Passive bridge from conveyor to conveyor

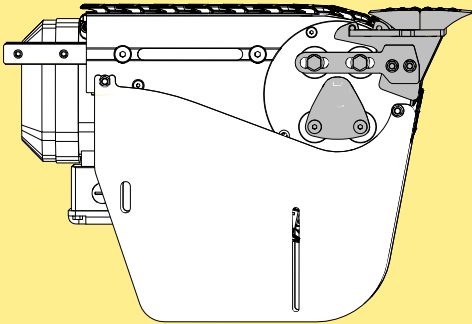

Passive bridge*

XBNG A85

From:	To:
Heavy Drive	Heavy Idler
Heavy Drive	Compact Idler
Comp./Med.Drive	Compact Idler
Comp./Med.Drive	Heavy Idler

* Use online configurator when ordering.

Attachment wire

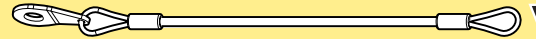

Wire for attaching roller to holder **FLX1006041**

*Also available as a configuration option through XBNG A85.

Sensor Kit

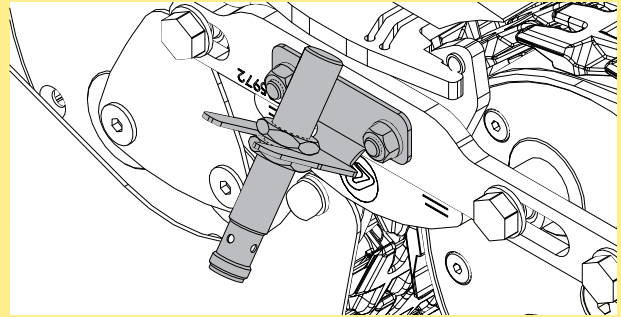

Bridge in position sensor kit

Conveyor to conveyor **FLX1006042**

External to/from Conveyor **FLX1006044**

*Also available as a configuration option through XBNG A85

Includes: Bracket & PNP sensor (NO), M12xL=70mm, M12 connector. No cables.

*Note

Bridges can not be used with cleated chain.

Passive bridge to or from machine or application, Single or double rollers

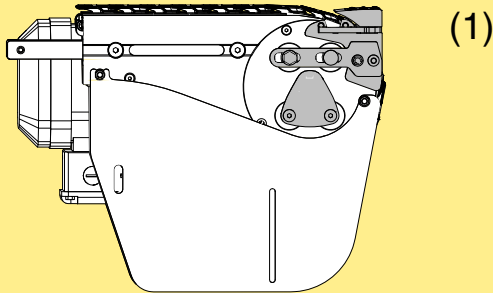

(1)

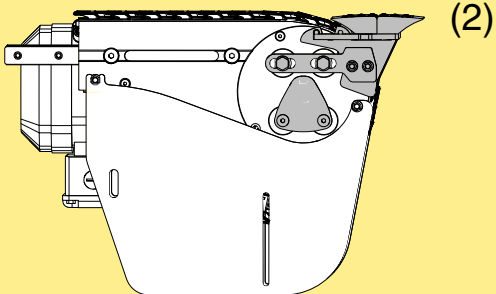

(2)

Passive bridge*

Single roller (1) or Double roller (2)

XBNG A85

From:	To:
Heavy Drive	External
External	Heavy Idler
Comp./Med. Drive	External
External	Comp./Med. Idler

* Use online configurator when ordering.

Bridge kit, heavy to beam

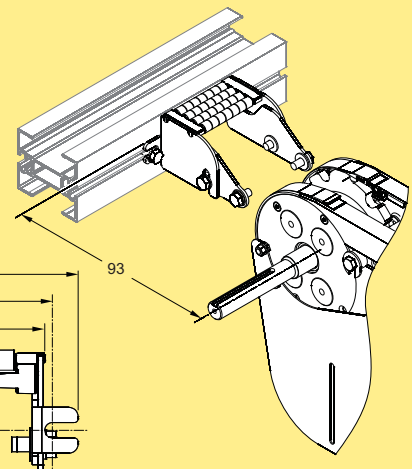

Bridge kit X85 to beam

5113517

Including roller bridge and mounting hardware. Suitable for connecting H drive units or idlers to beam.

Bridge kit, compact/medium to beam

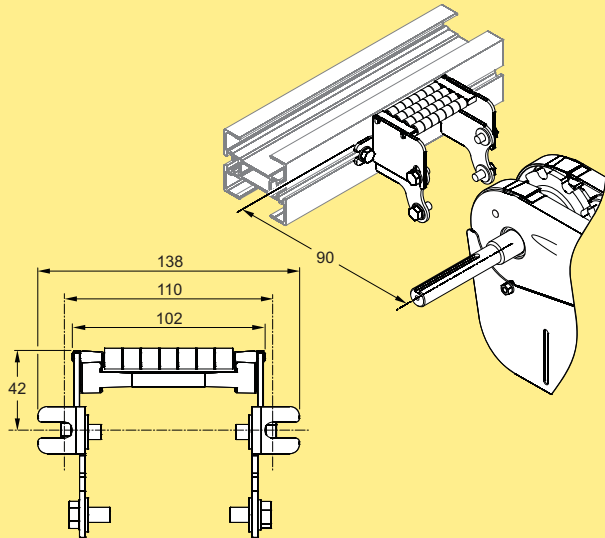

Bridge kit X85 to beam

5113566

*Including roller bridge and mounting hardware.
Suitable for connecting C or M drive units or idlers to beam.*

- PO
- CC
- X45
- XS
- X65
- X65P
- X85**
- X85P
- XH
- XK
- XKP
- X180
- X300
- GR
- CS
- XT
- HU
- WL
- WK
- XC
- XF
- XD
- ELV
- SC
- FST
- TR
- APX
- IDX

Wheel bends

Wheel bend, 30°

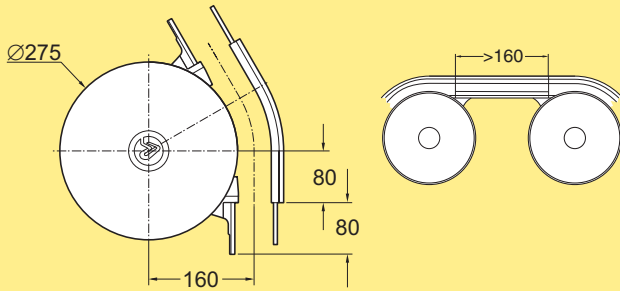

Wheel bend, 30° **XBBH 30A85R160**
Effective track length: 0,25 m 1-way (0,50 m 2-way)

Wheel bend, 210°

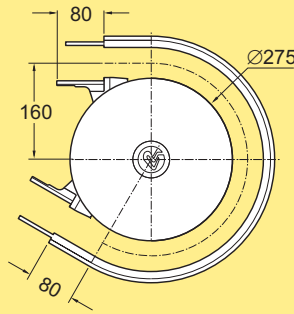

Wheel bend, 210° **XBBH 210A85R160**
Effective track length: 0,75 m 1-way (1,50 m 2-way)

Wheel bend, 45°

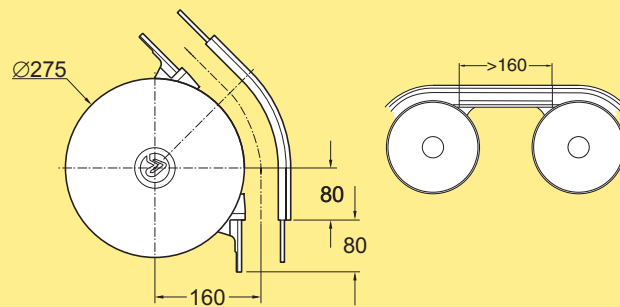

Wheel bend, 45° **XBBH 45A85R160**
Effective track length: 0,30 m 1-way (0,60 m 2-way)

Wheel bend, 30°–180°

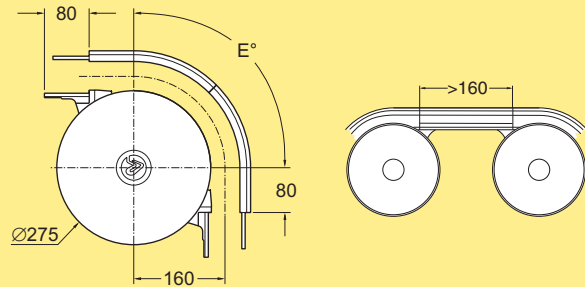

Wheel bend, 30°–180° **XBBH EA85R160**
The outer bend is cut in the middle to the desired angle and assembled using connecting strips.
The angle "E" must be specified when ordering.

Wheel bend, 90°

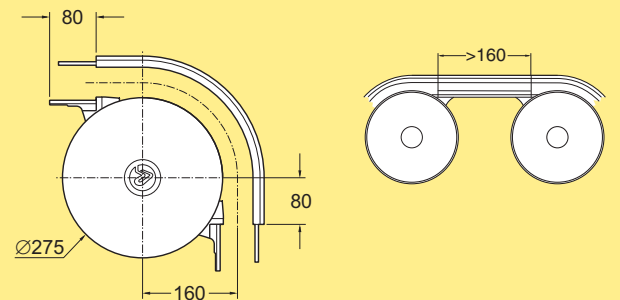

Wheel bend, 90° **XBBH 90A85R160**
Effective track length: 0,45 m 1-way (0,85 m 2-way)

Cover plate

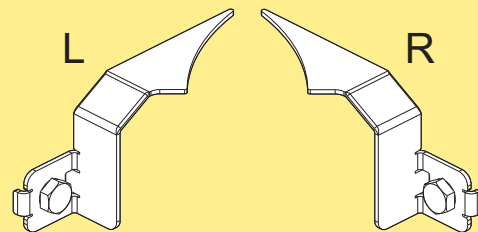

Cover plate, left **5113480**
Cover plate, right **5113481**

Note! To avoid pinch points add cover plate in Wheel bends or Wheel bend drive units when using XBTP 5A85 K. Assembly instructions 5113535.

Wheel bend, 180°

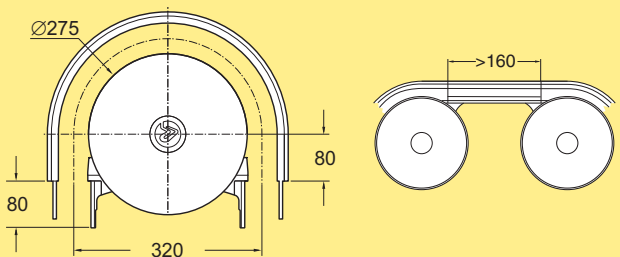

Wheel bend, 180° **XBBH 180A85R160**
Effective track length: 0,70 m 1-way (1,35 m 2-way)

Wheel cover for Wheel bend

- PO
- CC
- X45
- XS
- X65
- X65P
- X85**
- X85P
- XH
- XK
- XKP
- X180
- X300
- GR
- CS
- XT
- HU
- WL
- WK
- XC
- XF
- XD
- ELV
- SC
- FST
- TR
- APX
- IDX

Wheel cover for X65/XL, XT, X85, XH

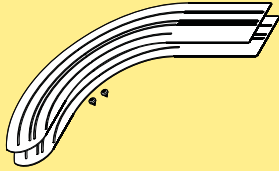

Wheel cover for X65/XL, XT, X85, XH 5112246
(Including one pair of Wheel cover 5112244 and 2 tap screw ISO 7049 4,2x6,5-C-H-A2K)

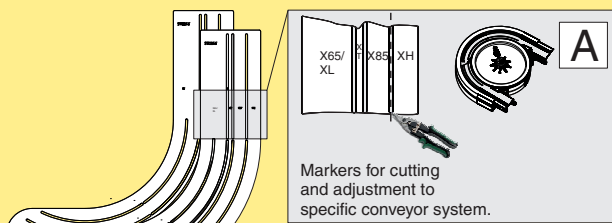

Markers for cutting and adjustment to specific conveyor system.

Example: To fit the wheel cover to a X85 system, cut the part marked XH (see figure A).
To fit the wheel cover to a XT system, cut the parts marked X85 and XH.

Plain bends

Plain bend, 30°

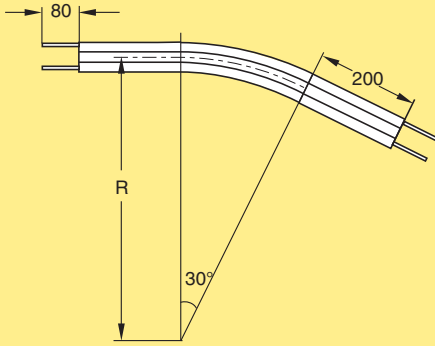

Plain bend, 30°±1°

- R=300±10 mm
- R=500±10 mm
- R=700±10 mm
- R=1000±10 mm

XBBP 30A85R3
XBBP 30A85R5
XBBP 30A85R7
XBBP 30A85R10

Effective track lengths:

- R300: 0,60 m 1-way (1,15 m 2-way)
- R500: 0,70 m 1-way (1,35 m 2-way)
- R700: 0,80 m 1-way (1,55 m 2-way)
- R1000: 0,95 m 1-way (1,85 m 2-way)

Plain bend, 60°

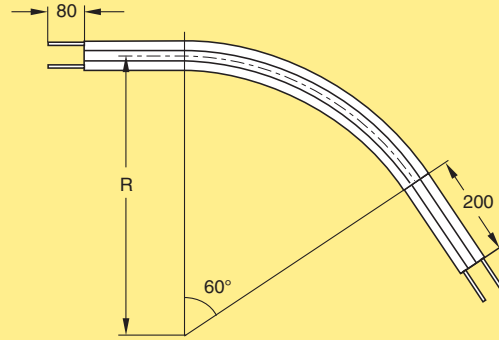

Plain bend, 60°±1°

- R=500±10 mm
- R=700±10 mm
- R=1000±10 mm

XBBP 60A85R5
XBBP 60A85R7
XBBP 60A85R10

Effective track lengths:

- R500: 0,95 m 1-way (1,85 m 2-way)
- R700: 1,15 m 1-way (2,30 m 2-way)
- R1000: 1,45 m 1-way (2,90 m 2-way)

Plain bend, 45°

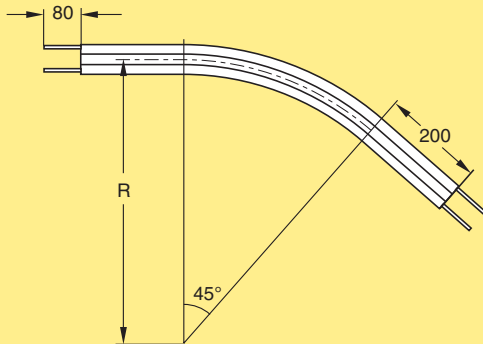

Plain bend, 45°±1°

- R=300±10 mm
- R=500±10 mm
- R=700±10 mm
- R=1000±10 mm

XBBP 45A85R3
XBBP 45A85R5
XBBP 45A85R7
XBBP 45A85R10

Effective track lengths:

- R300: 0,65 m 1-way (1,30 m 2-way)
- R500: 0,80 m 1-way (1,60 m 2-way)
- R700: 0,95 m 1-way (1,90 m 2-way)
- R1000: 1,20 m 1-way (2,40 m 2-way)

Plain bend, 90°

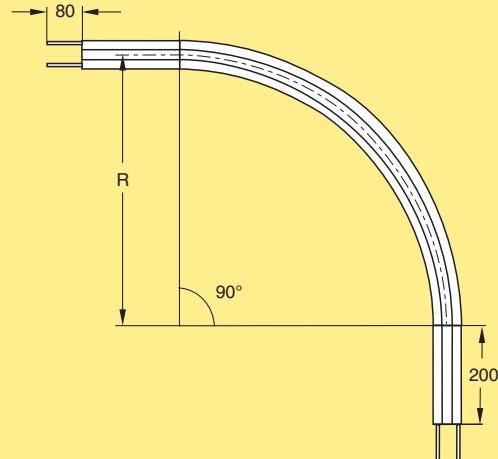

Plain bend, 90°±1°

- R=300±10 mm
- R=500±10 mm
- R=700±10 mm
- R=1000±10 mm

XBBP 90A85R3
XBBP 90A85R5
XBBP 90A85R7
XBBP 90A85R10

Effective track lengths:

- R300: 0,90 m 1-way (1,75 m 2-way)
- R500: 1,20 m 1-way (2,40 m 2-way)
- R700: 1,50 m 1-way (3,00 m 2-way)
- R1000: 2,00 m 1-way (3,95 m 2-way)

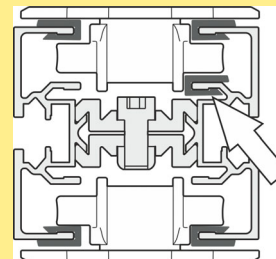

Cross-section of plain bend with narrow slide rails on the top and an extra slide rail in the inner part of the bend.

Vertical bends

PO

CC

X45

XS

X65

X65P

X85

X85P

XH

XK

XKP

X180

X300

GR

CS

XT

HU

WL

WK

XC

XF

XD

ELV

SC

FST

TR

APX

IDX

Vertical bend, 5°

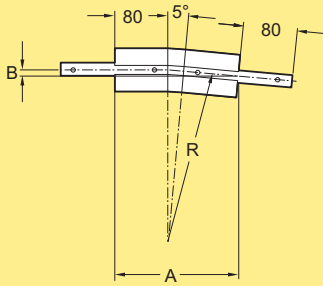

Vertical bend, 5°

R=400, A=195, B=9

R=750*, A=225, B=10

XBBV 5A85R4

XBBV 5A85R750

Effective track lengths:

R400: 0,20 m 1-way (0,40 m 2-way)

R750*: 0,25m 1-way (0,50 m 2-way)

*Note! Combination molded Vertical bend-Wheel bend is not possible.

Vertical bend, 30°

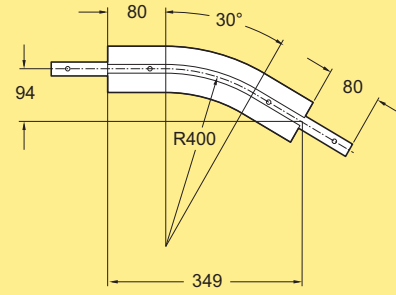

Vertical bend, 30°

XBBV 30A85R4

Effective track length: 0,40 m 1-way (0,75 m 2-way)

Vertical bend, 45°

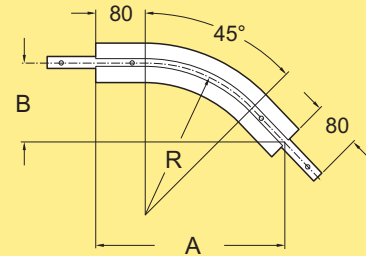

Vertical bend, 45°

R= 400, A=419, B=174

R=1000, A=844, B=349

XBBV 45A85R4

XBBV 45A85R10

Effective track length:

R400: 0,50 m 1-way (0,95 m 2-way)

R1000: 1,00 m 1-way (1,90 m 2-way)

Vertical bend, 7°

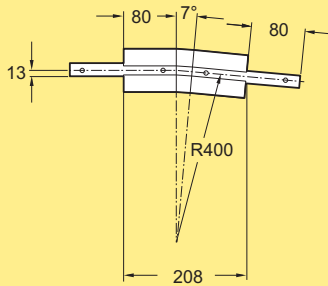

Vertical bend, 7°

XBBV 7A85R4

Effective track length: 0,25 m 1-way (0,45 m 2-way)

Vertical bend, 15°

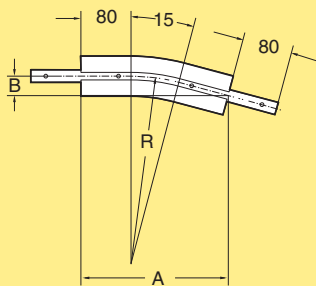

Vertical bend, 15°

R=400, A=261, B=34

R=750*, A=351, B=46

XBBV 15A85R4

XBBV 15A85R750

Effective track length:

R=400: 0,30 m 1-way (0,55 m 2-way)

R=750*: 0,40 m 1-way (0,75 m 2-way)

*Note! Combination molded Vertical bend-Wheel bend is not possible.

Vertical bend, 60°

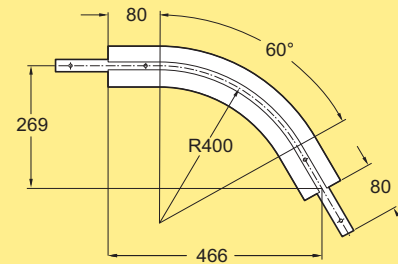

Vertical bend, 60°

XBBV 60A85R4

Effective track length: 0,65 m 1-way (1,20 m 2-way)

Vertical bends (continued)

Vertical bend, 90°

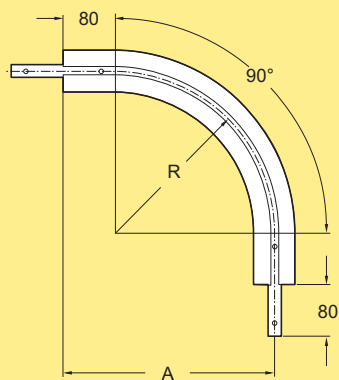

Vertical bend, 90°

R= 400, A= 480

R=1000, A=1080

XBBV 90A85R4
XBBV 90A85R10

Effective track length:

R400: 0,85 m 1-way (1,60 m 2-way)

R1000: 1,80 m 1-way (3,50 m 2-way)

Vertical bend, 5°–90°

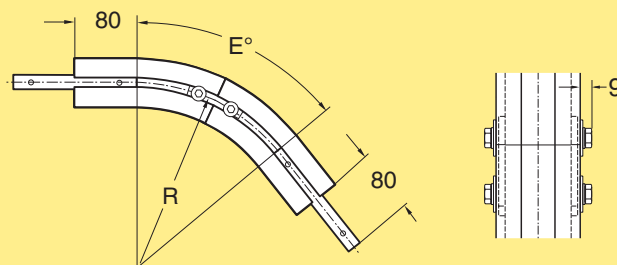

Vertical bend, 5°–90°

R=400

R=1000

XBBV EA85R4
XBBV EA85R10

The bend is cut in the middle to the desired angle and assembled using connecting strips.

The angle "E" must be specified when ordering.

Angle plates

Angle plate, straight

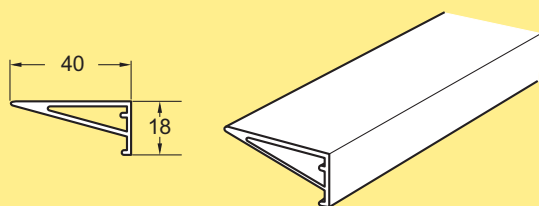

Angle plate
Length 3 m

XHRP 3

Angle plate for 180° bend

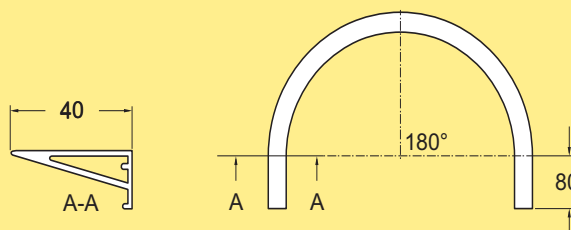

Angle plate for 180° bend
Used with XMBH 180R160 and
XMEW 180/5 H
Inner radius 202,5 mm

XMRM 180

Angle plate for 90° bend

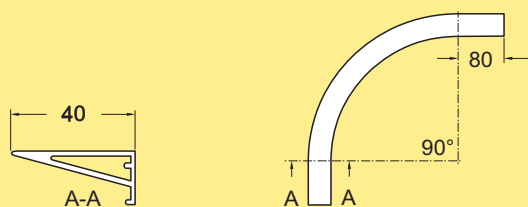

Angle plate for 90° bend
Used with XMBH 90R160
Inner radius 202,5 mm

XMRM 90

Front piece

Front piece
Length 3 m

XMVF 3

Front piece lower bend

Lower bend, 60°
Includes connecting strip with screws

XMVB 60R335

Sliding strip for front piece

Sliding strip for front piece
Length 2 m

XMVG 2

The sliding strip must be anchored to the front piece.
Rivets and tools for anchoring: see page 106.

Linkage kit for front piece

Linkage kit
W=170, D=43
W=270, D=93

**XHVK 43
XHVK 93**

Kit consists of two support pairs.

Front piece upper bend

Upper bend, 60°
Includes connecting strip with screws

XMVA 60R460

Bend support for front piece

Bend support
D=43 mm
D=93 mm

**XHVS 43
XHVS 93**

Drip trays

Drip tray

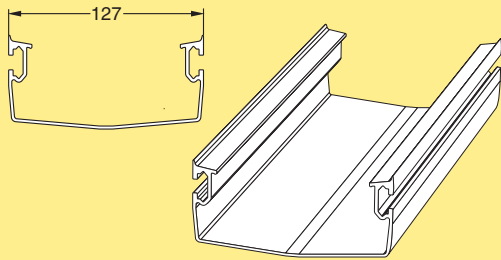

Drip tray
Length 3 m

XMDT 3x127 B

Connecting strip

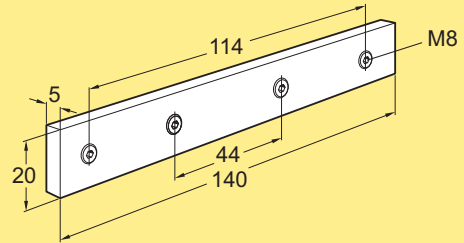

Connecting strip with set screws **XLCJ 5x140**

Note. Contains 10 pcs.

Drip tray bracket

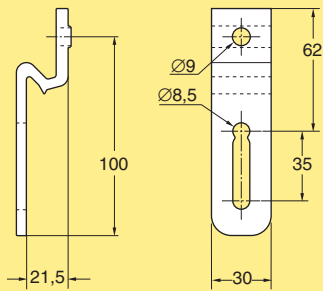

Drip tray bracket

XLDB 21x100