

# Conveyor system XTC – links and chains

Each link kit contains 10 links and 10 stainless steel pins, unless otherwise specified. Material abbreviations: See page III.

## Plain chain, straight-running

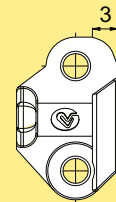
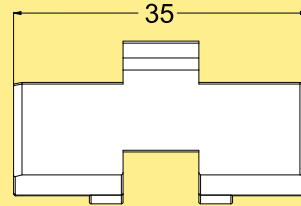
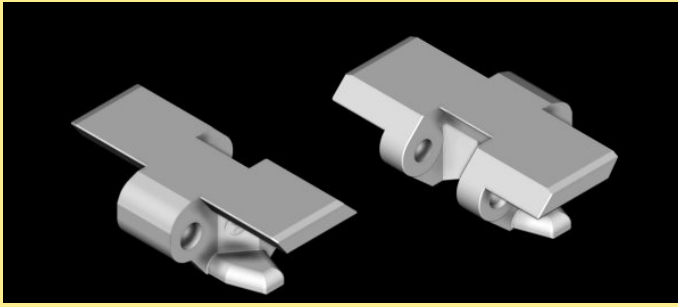

Only for straight-running conveyor.

Chain	Link(s)	Link kit(s)	Dimensions	Link weight	Material, link	Material, pivot
XUTP 3B35	5045029	5056662	Chain length 3 m	3 g	POM B	n. a.
5046328	5046329	5056663	Chain length 3 m	3 g	POM B ISD NAT	n. a.
XUTP 3B35 C	n.a.	5123388	Chain length 3 m	3 g	POM D	n. a.
XUTP 3B35 E	n.a.	5056664	Chain length 3 m	3 g	POM A COND	n. a.

## Plain chain

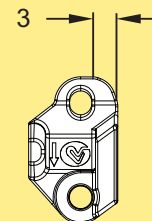
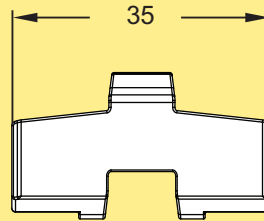
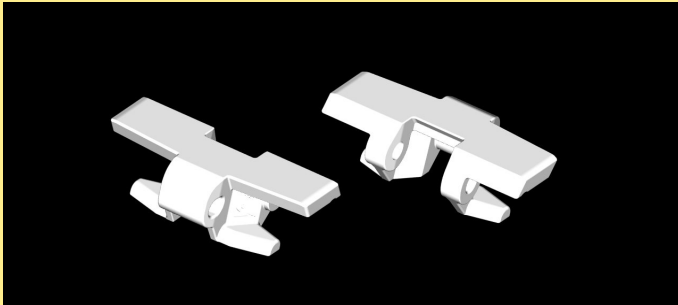

Chain	Link(s)	Link kit(s)	Dimensions	Link weight	Material, link	Material, pivot
XUTP 3A35	5118810	5123389	Chain length 3 m	3 g	POM B	n. a.
XUTP 3A35 E	5123371	5123390	Chain length 3 m	3 g	POM A COND	n. a.
XUTP 3A35 C	5123369	5123391	Chain length 3 m	3 g	POM D	n. a.

## Friction top chain

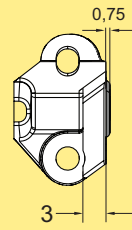
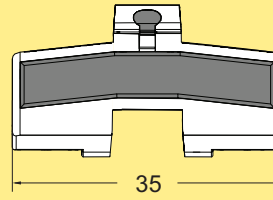
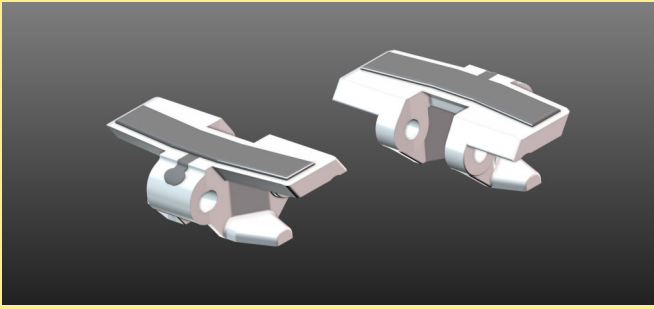

Pitch 12,7 mm.

Chain	Link(s)	Link kit(s)	Dimensions	Link weight	Material, link	Material, pivot
XUTP 3A35 F	5053821	5113049	Chain length 3 m	3 g	POM C	n. a.