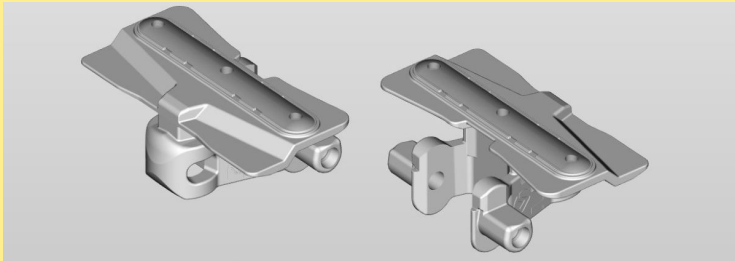
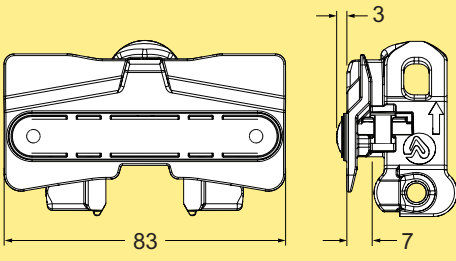

Spiral elevator, Compact X85 – links and chains

Each link kit contains 10 links, 10 plastic pivots, 10 stainless steel pins, 10 bearings and 10 pins for the bearings unless otherwise specified. Right/left: Bearings mounted on right/left side of link, considering chain forward direction. Material abbreviations: See page III.

Friction top chain

					
Chain	Link kit(s)	Bearing	Link weight	Material, link	Material, pivot
FLX1000776	FLX1000744	Right	34 g	POM B	PA66
FLX1000774	FLX1000744	Left	34 g	POM B	PA66

Flat friction top chain

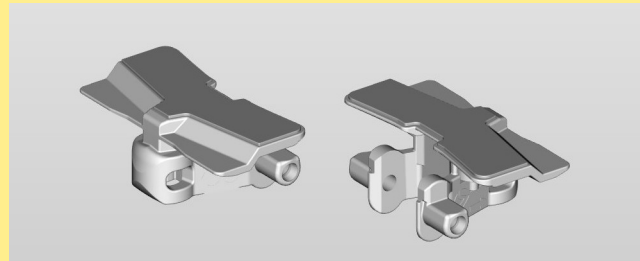
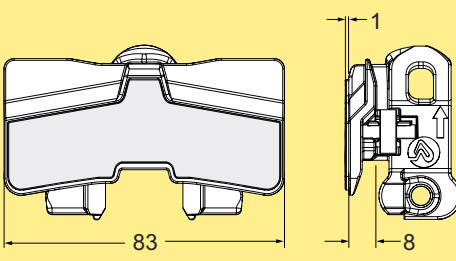
					
Chain	Link kit(s)	Bearing	Link weight	Material, link	Material, pivot
FLX1005963	FLX1005969	Right	34 g	POM B	PA66
FLX1005964	FLX1005969	Left	34 g	POM B	PA66

Cleated chain

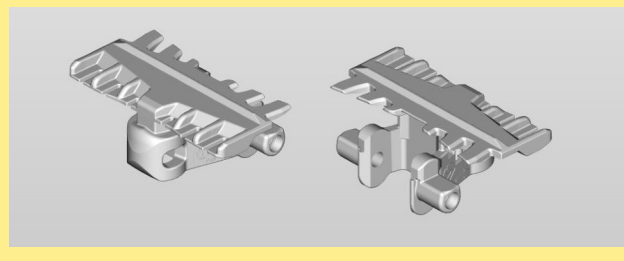
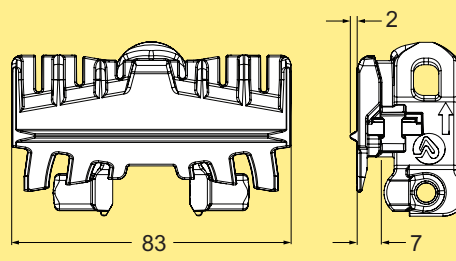
					
Chain	Link kit(s)	Bearing	Link weight	Material, link	Material, pivot
FLX1006080	FLX1006078	Right	32 g	POM B	PA66
FLX1006081	FLX1006078	Left	32 g	POM B	PA66

Plain chain

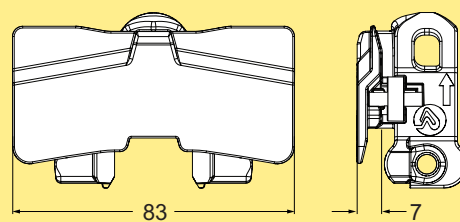
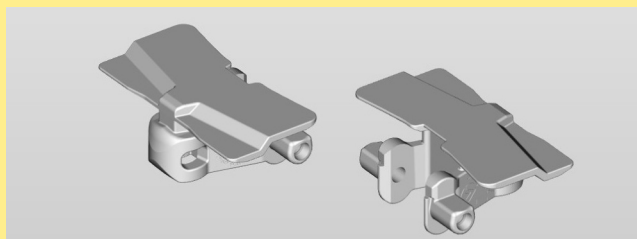

Only to be used for downward transports, allowing buffering. Transported products with low friction against the chain might give an unintentional easy slide.

Chain	Link kit(s)	Bearing	Link weight	Material, link	Material, pivot
FLX1007997	FLX1008000	Right	32 g	POM B	PA66
FLX1007998	FLX1008000	Left	32 g	POM B	PA66