

MTT - Modular twin track

Contents

MTT modular twin track concept.....	1	MTT conveyor unit	12
MTT control setup	2	Conveyor unit components	13
Complete MTT module XTUM	4	MTT Transfer unit.....	15
MTT pallets	5	MTT transfer kits	16
MTT mechanical units	9	MTT transfer kit components	17
Frame unit	9	Support unit	18
Module dust cover	10	Controls.....	19
MTT frame components	11		

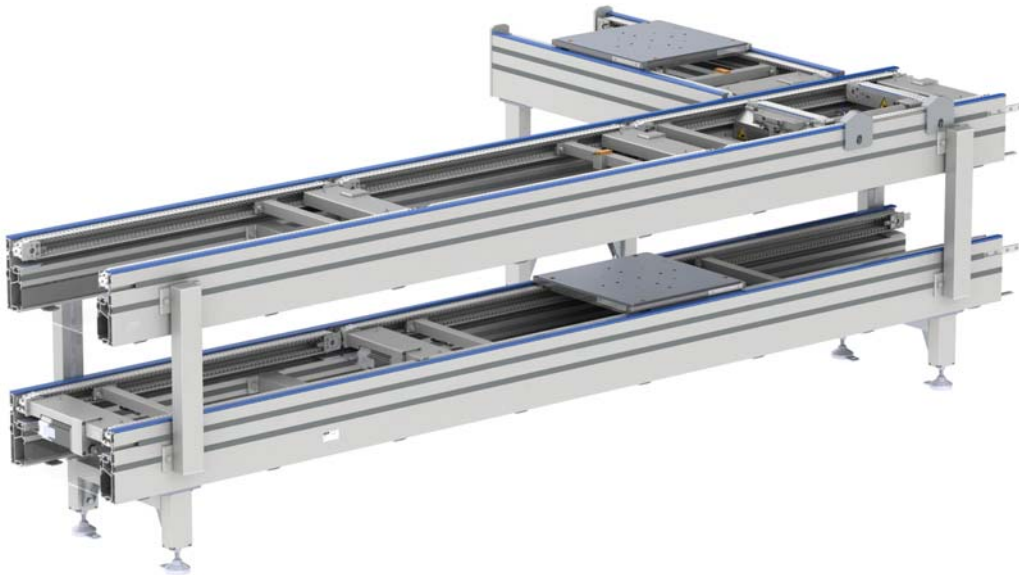

MTT modular twin track concept

Flexlink's pallet system MTT (Modular Twin Track) is developed specially for environments with high requirements, such as cleanroom and ESD demands. It is also especially suitable to handle fragile products that need to be handled with care.

- **Ready for cleanroom and ESD environments** meets battery and electronic industry standards.
- **Soft, low noise pallet handling** with single-pallet control and fully electrical architecture ensuring product handling precision, energy efficiency and low maintenance.
- **Pre-built mechatronic modules** enabling reduced engineering, quick installation and ramp-up

Pre-defined modules

Fully modular setup with complete mechatronic modules delivered tested and ready from FlexLink. The system can handle pallet loads up to 30Kg and system speeds up to 20m/min.

Smart integrated module control

The MTT system is a fully electrified platform featuring pre-installed power and signal cabling within each

module. Every MTT module is delivered equipped with AC/DC power converter for 24VDC and SCDC controller for complete signal management inside the module. This integrated design significantly reduces engineering time and ensures quick, hassle-free installation and rapid start-up on site.

Examples of application areas

- Cleanroom environments with low humidity demand, such as battery production.
- Cleanroom production with ESD requirements, such as semiconductor industry.
- All production where fragile products are handled.
- Production lines for assembly of electronic and medical equipment.

MTT

MTT control setup

The MTT platform is developed with a modular design approach dividing the product into functions that is combined to mechatronic modules. MTT uses the FlexLink Controls Platform (FCP), to provide pre-engineered control solutions for each module. By using these standardized controls, much of the module-specific logic can be downloaded directly, reducing programming effort and significantly shortening line control setup time.

When designing the MTT layout, FlexLink Design Tool (FLDT) will help you configure the mechatronic modules. This ensures that the all needed control hardware is included and that an I/O mapping for all signals is generated.

SCDC controller

The SCDC controller acts as a gateway between the equipment within the mechatronic modules and the main PLC, ensuring seamless communication and easy setup. The SCDC also provides flexibility to integrate project specific equipment into the control system.

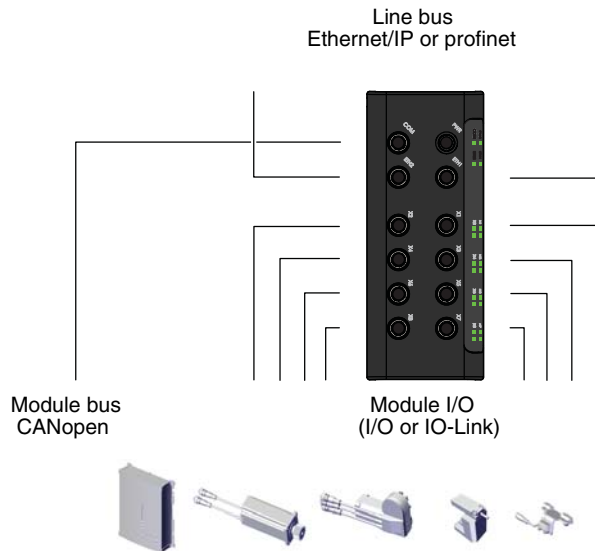

24VDC power unit

Each MTT module include an AC/DC power converter for all 24V DC equipment.

Drive motor

Conveyors and transfers includes 24VDC high torque stepper motors.

RFID

Conveyors and transfers can be ordered with RFID readers in place at delivery. The reader is mounted to perfectly read the tags placed centrally underneath of the pallets. The RFID reader communicates via I/O-Link with the SCDC controller in the actual module.

Sensors

All pallet position sensors in the MTT platform are of photo electric type.

Module cabling

The pre-installed power and signal cabling within the modules are nicely hidden within cable ducts in the main module frame. The module will come with a standard cable labeling setup.

MTT main control setup

The system-level control requires a central PLC cabinet equipped with an HMI screen. A main cable duct (not included in the MTT modules) is necessary to connect the modules to the PLC using 3-phase power and network connections.

Pre-configured PLC blocks and E-plan templates are available to minimize engineering effort and streamline the control setup process.

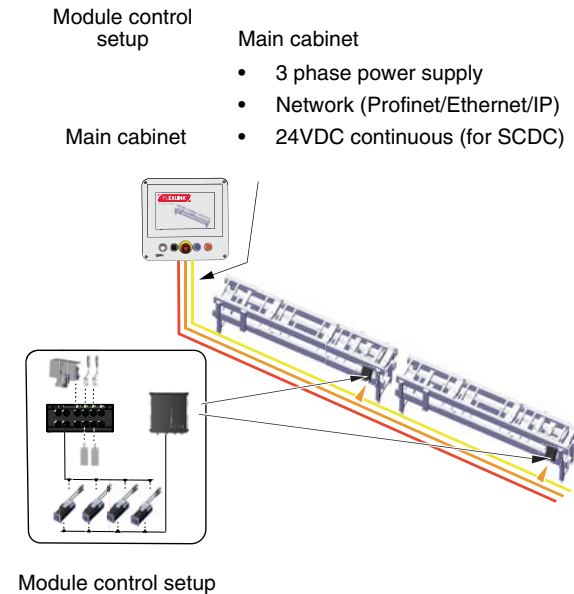

Software and electrical design

All equipment is delivered with the latest firmware, which can be upgraded to newer revisions after installation.

Pre-configured PLC template function blocks for all module variants, along with example code for line logic programming, are available. For more details, please contact your local sales office.

These modular function blocks enables easy customization and fast commissioning. Additionally, all modules come with pre-designed EPLAN templates, clearly showing all I/O points and their connections to the SCDC controller.

System	MTT
Pallet	Pallet size: 400x400 up to 640x640
Pallet thickness	8 mm
Permitted load/100 mm pallet length	8 kg
Max total pallet and payload weight	30 kg
Pallet material	Aluminium plate and conductive or dissipative plastic frame
Chain width	35 mm
Chain pitch	12,7 mm
Chain options	For clean and/or ESD environments
Max accumulated weight on a single conveyor	30 kg (one pallet at the time are allowed on the conveyor)
Conveyor length	200-2000 mm
Conveyor speed	0-20 m/min
Power source, Conveyor and transfer modules	Electric 24 VDC
Controller, SCDC	Interface for all drives and devices.
RFID	13,56 MHz
Noise level	< 70 dBA
Battery/ standard environment	Managing ISO 5 cleanroom with dry and zink free requirements
ESD environment	Managing ISO 5 cleanroom with ESD, Dissipative

Complete MTT module XTUM

How to order XTUM modules

Complete MTT mechatronic modules (XTUM), with its high level of alternatives and configuration options require to be designed through FLDT, FlexLink design tool.

FLDT enable an easy design of the whole system in parallel as each module are configured with conveyors, transfers and hardware control needed to fulfill the product system requirements.

Contact your local FlexLink sales organization if you need to support and help to build up your future MTT production system in FLDT.

The preferred way to order XTUM modules is as complete mechatronic modules ready and tested at delivery from FlexLink. As an alternative they can be ordered without electrical cabling, only including 24V motors and SCDC controller for controlling of motors



The picture above shows an example of a design of a MTT system in FLDT

Main building blocks in a XTUM module

Items normally included in a configured XTUM module:

- Frame unit
 - Single or double level system
 - Free length between 1-4 m
- Conveyor unit- Free length up to 2 m
 - Maximum of four conveyors per module level
- Transfer unit
 - FLDT will choose the correct kit required for each traffic situation.
- Hardware control
 - Power unit and SCDC equipment required to handle all equipment included in the module
 - Sensor and RFID
 - Cabling hidden in a cable duct inside the frame beams
- Other
 - Legs for modules located on floor level
 - Satellites for bridge and offline stations.

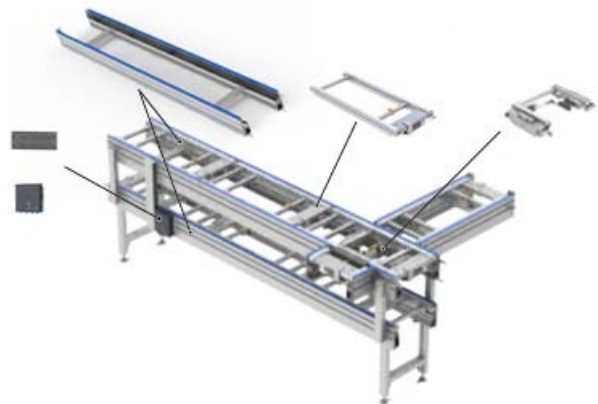

Mechatronic MTT module

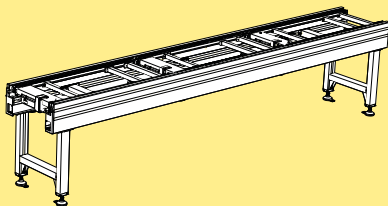

One level module

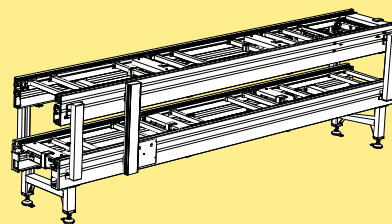

two level module

Mechatronic MTT module

XTUM

**Use engineering tool FLDT for module configuration*



Introduction

The pallet XTPP M is available in six standard sizes, ranging from 400x400 mm to 640x640 mm.

A pallet can be configured with two alternative frame materials; conductive or dissipative.

Pallets feature a predefined hole pattern for easy fixture assembly and can be ordered either fully assembled or unassembled. The unassembled option allows for customized machining or complete replacement of a pallet plate to meet specific requirements.

Each pallet includes a centrally positioned reflector plate underneath for accurate sensor reading. This plate also features a dedicated pocket for an RFID tag, which can be ordered pre-installed for convenience. The reflector plate is essential for proper operation of the MTT system.

XTPP M can be ordered using the web-based configurator or via FlexLink Design Tool during design of the complete system of XTUM modules.

When the following questions has been answered, the pallet is fully defined:

Question	Choices	Description code
Pallet width PW?	400 mm	400
	480 mm	480
	640 mm	640
Pallet length PL?	400 mm	400
	480 mm	480
	640 mm	640
Pallet plate?	Thickness 8 mm	PT
	No plate	No
Reflector unit?	Yes	RU
	No	No
Reflector unit fasteners	Yes	SS
	No	No
Locating bushings?	Yes	LB
	No	No
RFID tag?	Yes	RF
	No	K
Delivery form?	Assembled	A
	Unassembled kit	K
Type?	ESD cleanroom (dissipative)	D
	ESD Dry cleanroom (conductive)	V

Configurator output example:

Item No	Description
XTPP M	480x480-PT-RU-SS-LB-RF-A-V

MTT

Pallet introduction

Pallet width (PW) × pallet length (PL)

Pallet width and pallet length. PL is basically the pallet dimension in the direction of pallet movement in the main flow. In some modules the pallet moves “sideways”, for example when transferred from one line to another.

Material specifications

Pallet plate..... 8 mm ±0,1 Aluminium plate
 Frame(Dry cleanroom) .. Electrically conductive UHMW-PE
 Frame(ESD cleanroom) Electrically dissipative UHMW-PE

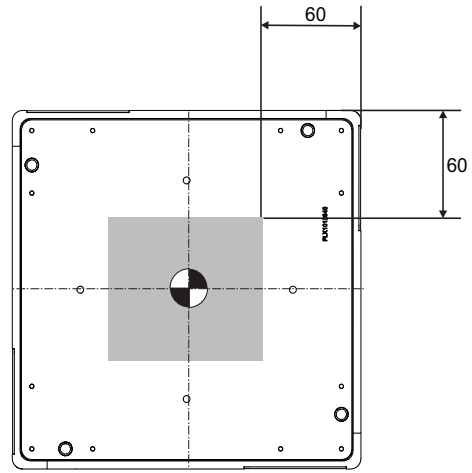

Size (PW × PL)	Pallet weight (kg)	Max load on pallet (kg)
400 × 400 mm	5,0	25
400 × 480 mm	5,8	24
400 × 640 mm	7,5	22
480 × 480 mm	6,7	23
480 × 640 mm	8,7	21
640 × 640 mm	11,2	18

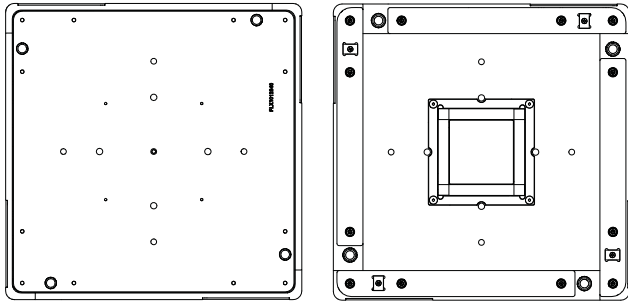

Pallet side, top and bottom view.

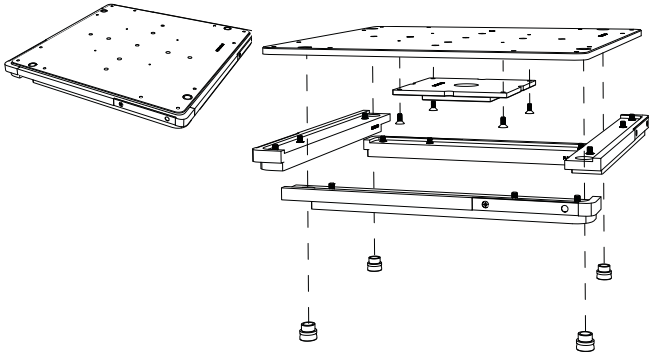

Pallet loading

Recommended centre of gravity of the product on the pallet (including fixture) should be located within the grey marked area according to the picture to the right.

Pallet fixture holes

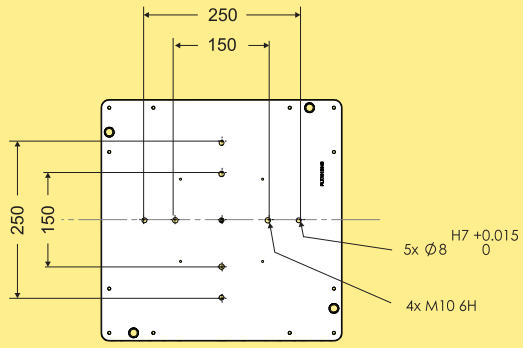

Pallet dimension 400x400 and 480x480

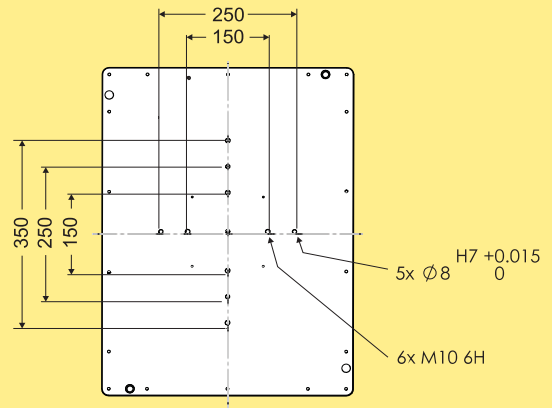

Pallet dimension 400x480 and 480x640

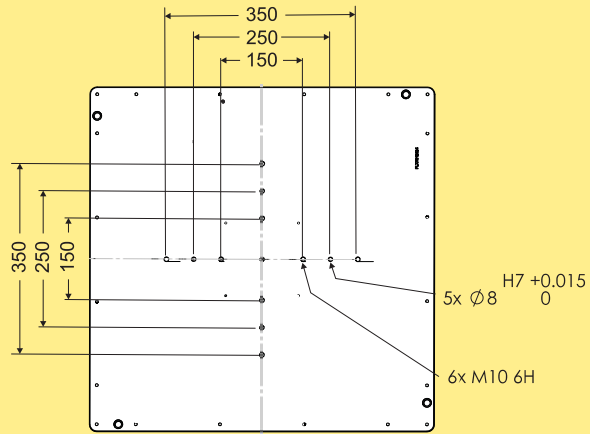

Pallet dimension 640x640



Pallet PW×PL

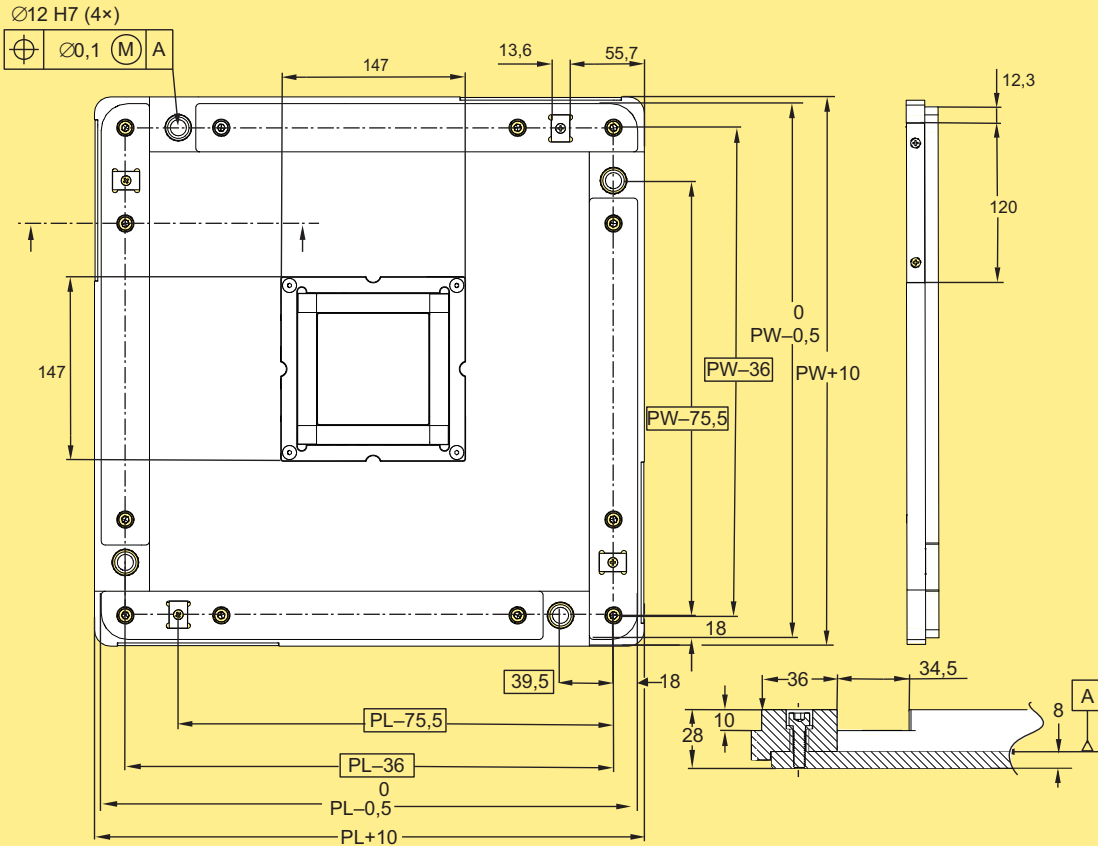

PW×PL	400×400	400×480	400×640	480×480	480×640	640×640
	0,6	0,8	0,8	0,8	1,0	1,0

Pallet PW × PL mm

XTPP M PW×PL

When ordering, insert the pallet width and the pallet length instead of PW×PL in the designation.

For building non-standard pallets in combination with customer supplied pallet plates. The bushings are designed for plate thickness 8 mm and should be press-fitted into Ø16 mm P7 holes.

Frame kit

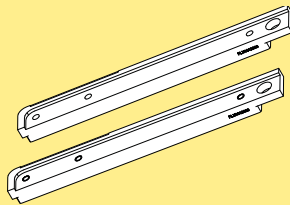

Frame kit

Dissipative:

400

480

640

Conductive:

400

480

640

FLX1012913

FLX1014142

FLX1012871

FLX1014088

FLX1014089

FLX1013609

Including reader kit with brackets

Bushing kit

Bushing x4

FLX1013710

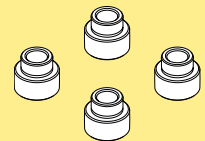

RFID



RFID tag

IQC21-30, 1024 kbit, 25 pcs

5113121

Introduction

We recommend ordering complete XTUM modules through FLDT. These modules will be fully assembled at FlexLink facilities and delivered complete with all equipment as configured. If preferred, individual mechanical building blocks - such as frames, conveyors, and transfers can be ordered separately through the Online store as configured items. The following chapter includes these configured mechanical items as well as separate components for customization.

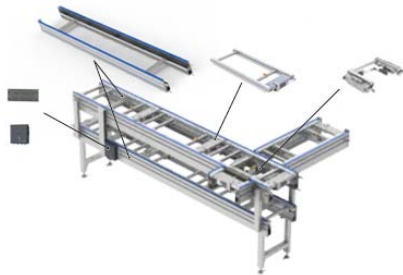

A complete MTT module can be configured as a one- or two level version. When ordering XTUM modules, this is handled automatically. However, when ordering individual components, all parts must be selected separately. Dust covers are available as an optional feature.



One level MTT frame:

- 1 pcs XTUF FM

Two level MTT frame:

- 2 pcs XTUF FM
- 4 pcs XTUF SM

Frame unit

XTUF FM units are delivered fully assembled and are available in lengths up to 4 meters. They support standard pallet widths of 400 mm to 640 mm. The configuration process allows you to select the most suitable setup for your application. Covers for built-in cable ducts and slide rails for pallet guidance are always included.

Each end of a XTUF FM frame unit can be equipped with one of three types of end pieces:

- Connecting strip - for joining to another frame
- End stop - required when the frame is not connected to another frame.
- End caps - for perpendicular connection to another module.

One level frame unit

Frame unit **XTUF FM**

**Use online configurator when ordering*

When the following questions has been answered, the frame unit is fully defined:

Question	Choices	Description code
Pallet width PW?	400 mm 480 mm 640 mm	400 480 640
Frame unit beam length L1?	$200 \leq L1 \leq 4000$ mm	L1
Cross beam 1 position?	$60 \leq L2 \leq L1-60$ mm No	L2 No
Cross beam 2 position?	$60 \leq L3 \leq L1-60$ mm No	L3 No
Type?	ESD cleanroom Dry cleanroom	D V
T-slot covers?	Yes No	TSC No
Start end?	End caps End stops Connecting strip No	EC ES CS No
Opposite end?	End caps End stops Connecting strip No	EC ES CS No

Configurator output example:

Item No	Description
XTUF FM	480-4000-850-3150-D-TSC-EC-ES

When the following questions has been answered, the module is fully defined:

Question	Choices	Description code
H (TOC)?	$300 \leq H \leq 710$ mm	H

Configurator output example:

Item No	Description
XTUF SM	300

Vertical beam for two level frame

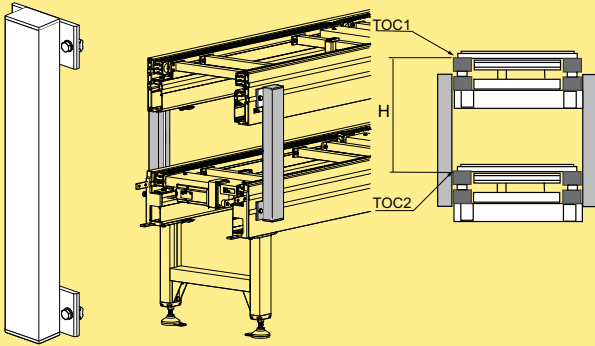

Vertical beam

XTUF SM

Including brackets

Note. Four support beams are required for each two level module.

**Use online configurator when ordering*

Module dust cover

Dust cover is often used to cleanroom environments to avoid dust to fall down to a lower level system level and simplify cleaning. The dust cover is also a good solution to avoid availability from below. The cover is easily assembled with brackets into guides on the bottom of the frame.

ESD antistatic panel

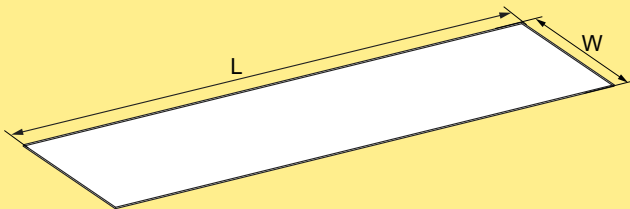

Panel

L= 1985 mm w= 400 mm **FLX1014067 1985**

L= 1985 mm w= 480 mm **FLX1014068 1985**

L= 1985 mm w= 640 mm **FLX1014069 1985**

Antistatic transparent PC, thickness 5 mm

Bracket kit for panel assembly

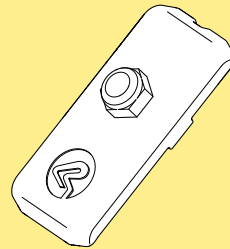

Bracket kit for panel assembly

FLX1010279

*Use for fixing the plastic plates in the frame
Recommended to use two brackets every 400 mm of plastic plate.
Includes fasteners*



H-profile

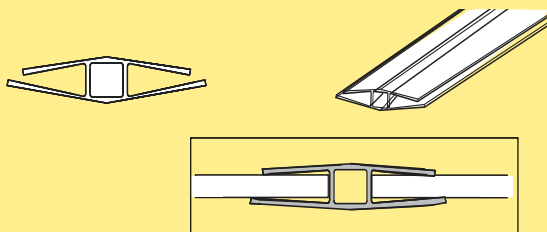

H-profile

FLX1014096 3

*Use between ESD antistatic panels
PC, length 3 m*

Connecting strip, stainless

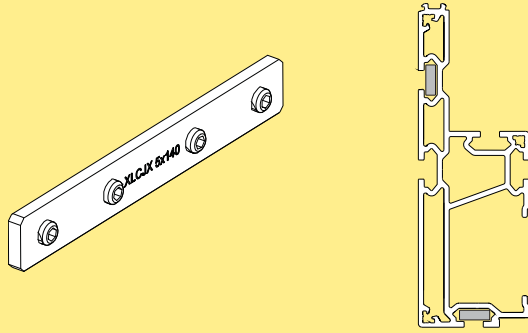

Connecting strip
Stainless steel,
XLCJX 5x140
Including M8 set screws. Contains 10 pcs

End cap

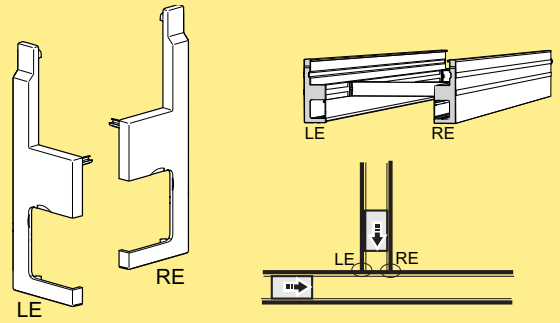

End cap
Left side
Right side
PA, dark grey
XCBE 64x189 LE
XCBE 64x189 RE

Use for perpendicular connection interface with other module.

End stop kit

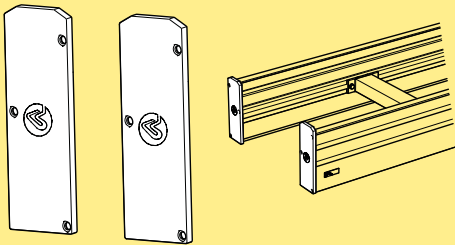

End stop
FLX1015275
Used for safety at the end of the module.
Including fasteners. Contains 2 pcs.

Cable duct cover

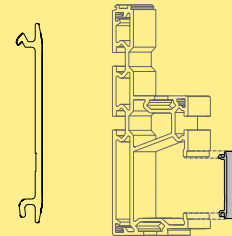

Cover for cable duct, 55 mm.
Length 4 m
PE, grey
XCCC 4x55

Crossbeam frame

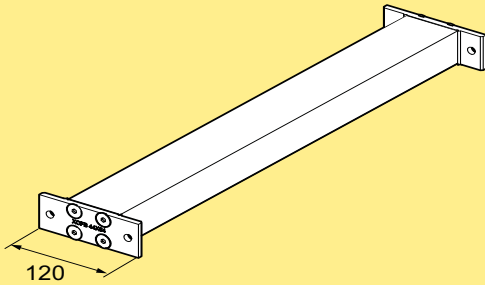

Crossbeam
Pallet width 400 mm
Pallet width 480 mm
Pallet width 640 mm
XTUF BM 400
XTUF BM 480
XTUF BM 640

Including fasteners
*Use online configurator when ordering

Holder

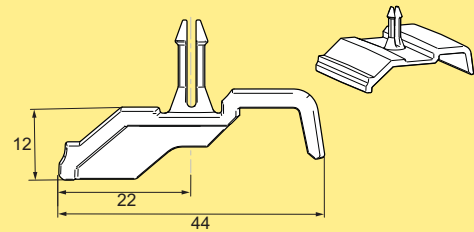

Holder for M12-T splitter cable in
cable duct
POM, grey
FLX1012938

Cover strip for T-slot

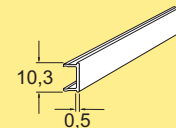

Cover strip for T-slot
Length 3 m
PVC, grey
XCAC 3 P

MTT

MTT frame guide rail

The following figures show the pallet guide rail location on the MTT frame.

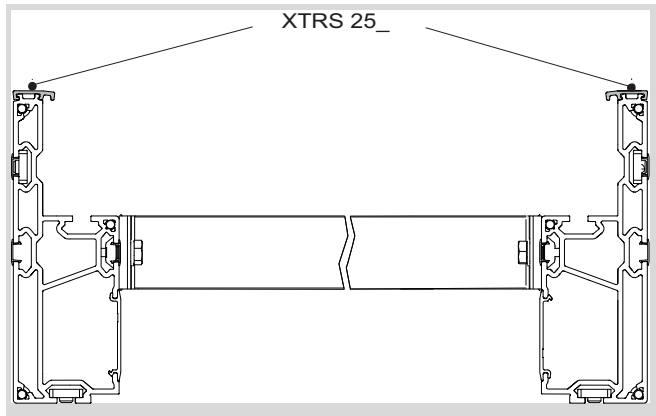

Guide rail for pallet guiding

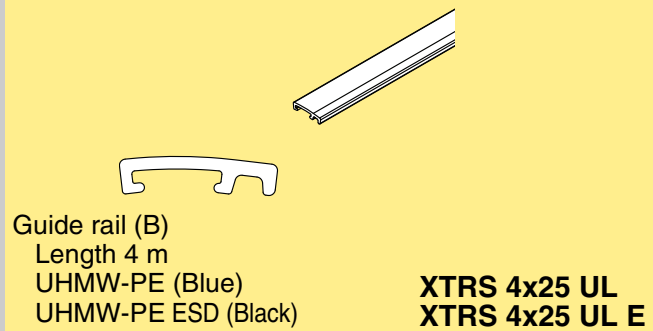

MTT conveyor unit

The XTUC S11M is a twin-track pallet conveyor featuring a flexible plastic chain design with built in return chain. The conveyor is available in lengths up to two meters. It supports the standard pallet widths of 400 mm, 480 mm and 640 mm.

The conveyor is delivered fully assembled, complete with all components according to the specified configuration and engineered for quick and easy assembly onto the MTT frame. Optional accessories include sensors and RFID readers for enhanced functionality.

A conveyor that should be fitted into a MTT frame require one set of FLX1013550 Locking kit per conveyor for assembly to the MTT frame.

Complete XTUM modules include all conveyors as defined in the FLDT configuration, eliminating the need to order conveyors separately.

When the following questions has been answered, the conveyor is fully defined:

Question	Choices	Description code
Pallet width PW?	400 mm	400
	480 mm	480
	640 mm	640
Pallet length PL?	400 mm	400
	480 mm	480
	640 mm	640
Conveyor length L1	$200 \leq L1 \leq 2000$ mm	L1
Sensor	Drive- & Idler end	DIS
	Drive end	DS
	Idler end	IS
	No sensors	No
RFID	Drive end	RFD
	Idler end	RFI
	No	No
Motor position	Right	R
	Left	L
Type	ESD cleanroom (Dissipative)	D
	Dry cleanroom	V

Configurator output example:

Item No	Description
XTUC S11M	400x480-0750-DIS-RFD-R-D

Conveyor unit

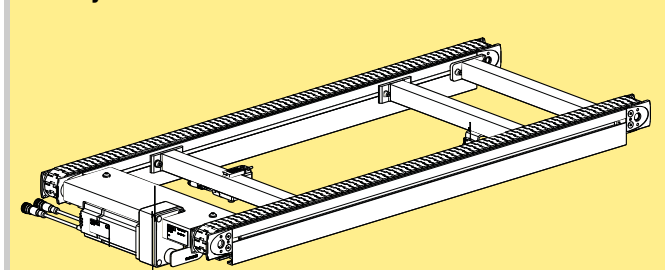

Conveyor unit **XTUC S11M**

Note! XTUC S11M must be connected to a SCDC controller.

**Use online configurator when ordering*

Minimum clearance distance

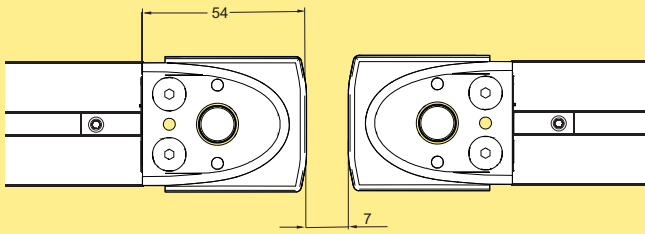

When two conveyors meet end to end or when a conveyor ends, they must be separated by a minimum clearance distance.

Locking kit

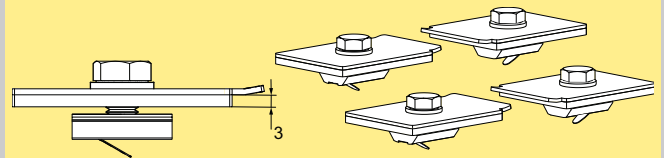

Locking kit for conveyor unit **FLX1013550**

Use to mount the conveyor module to the frame.
Contains four locking units with fasteners.

Conveyor unit components

The components below are all included in the configuration of an XTUC S 11 M conveyor and therefore normally is not needed to be purchased as separate items. i

Crossbeam conveyor incl. sensor kit

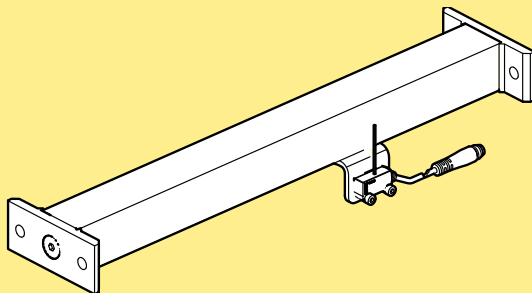

Crossbeam
Pallet width 400 mm **XTPB 400C**
Pallet width 480 mm **XTPB 480C**
Pallet width 640 mm **XTPB 640C**

Including fasteners
*Use online configurator when ordering

RFID reader/writer kit

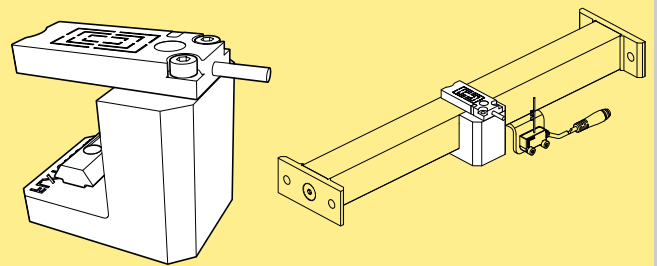

RFID kit **XTPB RFC**

Including reader kit with brackets

Crossbeam conveyor

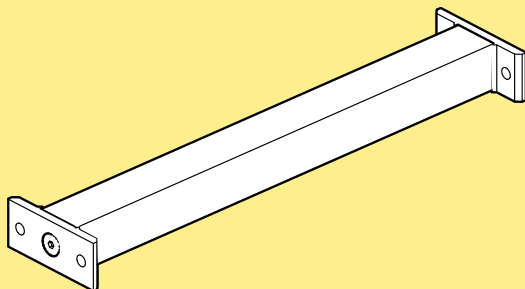

Crossbeam
Pallet width 400 mm **XTPB 400**
Pallet width 480 mm **XTPB 480**
Pallet width 640 mm **XTPB 640**

Including fasteners
*Use online configurator when ordering
Note! only for idler end side.

Cover strip

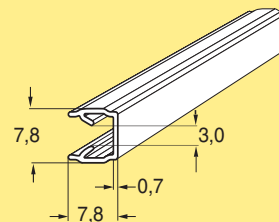

Cover strip for T-slot
Length 3 m
PVC, grey

XFAC 3 T

MTT

Chain

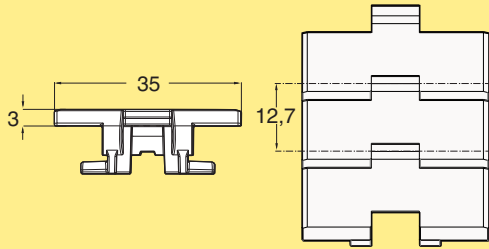

Plain chain, XTC
Pitch 12,7 mm. Only for straight-run-
ning conveyor (XTC).

Length 3 m

Standard chain

Standard link kit **

XUTP 3B35
5056662

Dissipative chain *

Dissipative link kit **

5046328
5056663

*Use with conductive slide rail.

**Link kit contains 10 links, 10 steel pins

Mounting tool for slide rail

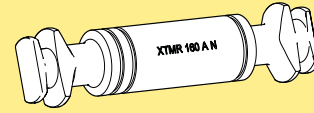

Mounting tool for slide rail

XTMR 160 A N

Note! Use for bottom conveyor slide rails.

Slide rail configuration

The following figure show the slide rail location on the
MTT conveyor, XTUC S11M.

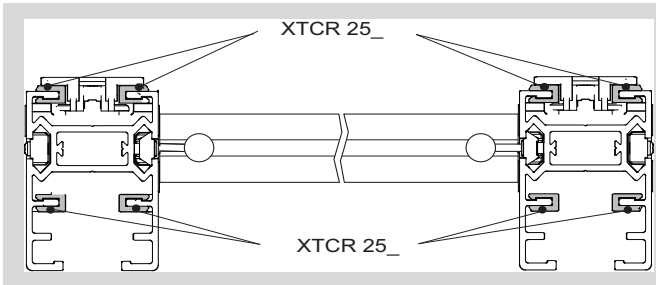

Slide rail, type A

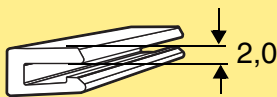

Slide rail (A)

Length 25 m

UHMW-PE (Blue)

UHMW-PE ESD (Black)

XTCR 25 UL
XTCR 25 UL E

Mounting tool for slide rail

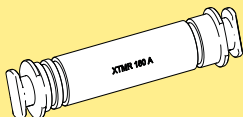

Mounting tool for slide rail

XTMR 160 A

Note! Use for upper conveyor slide rails.

MTT Transfer unit

An MTT transfer unit consists of a configured XTPT LM transfer unit combined with a transfer kit. Transfer kits are selected based on required functions and transfer directions.

The XTPT LM unit is delivered fully assembled and includes all necessary equipment for easy installation into an XTUF FM frame, as well as simple adjustment for correct operation. Transfer kits are supplied partially for quick installation onto the transfer and the frame module.

When configuring a complete XTUM module, the correct XTPT LM transfer and transfer kit are automatically selected and included.

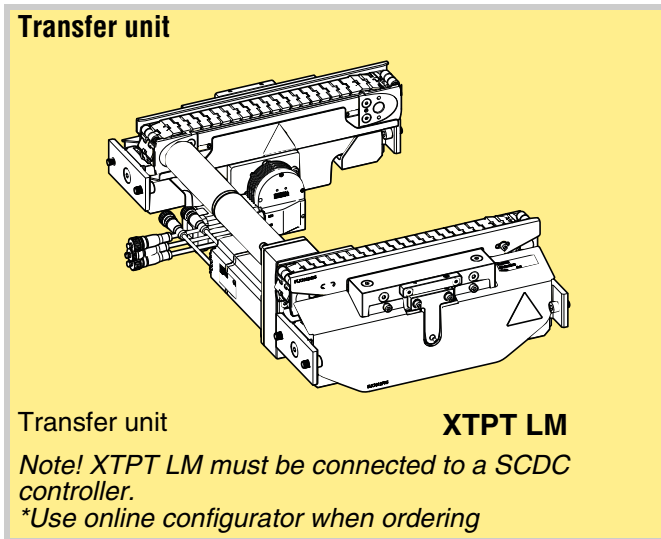

When the following questions has been answered, the transfer is fully defined:

Question	Choices	Description code
Pallet width PW?	400 mm	400
	480 mm	480
	640 mm	640
Pallet length PL?	400 mm	400
	480 mm	480
	640 mm	640
Type?	ESD cleanroom (dissipative)	D
	Dry cleanroom	V

Configurator output example:

Item No	Description
XTPT LM	480x480-V

MTT transfer kits

Four different transfer kits are available to add to the transfer. The kit includes different items depending on the desired transportation flow. The illustrations show all possible product flows for each kit. Each kit can be ordered with or without an RFID reader.

Transfer kit 1

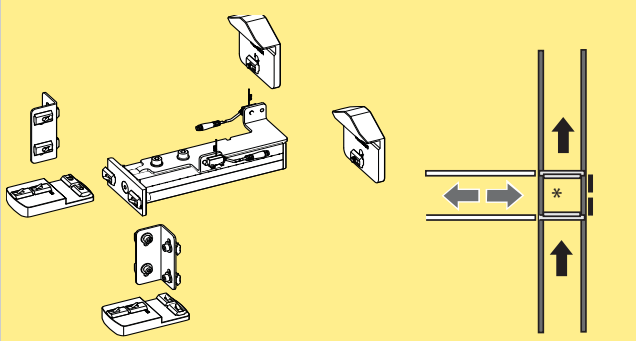

Transfer kit 1
without RFID
with RFID

**FLX1013280
FLX1013284**

Transfer kit 4

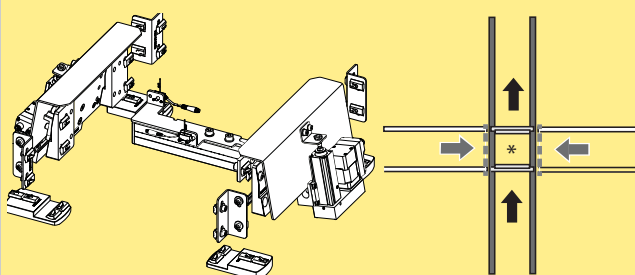

* transfer position and possible traffic flows

Transfer kit 4
without RFID
with RFID

**FLX1013283
FLX1013287**

Transfer kit 2

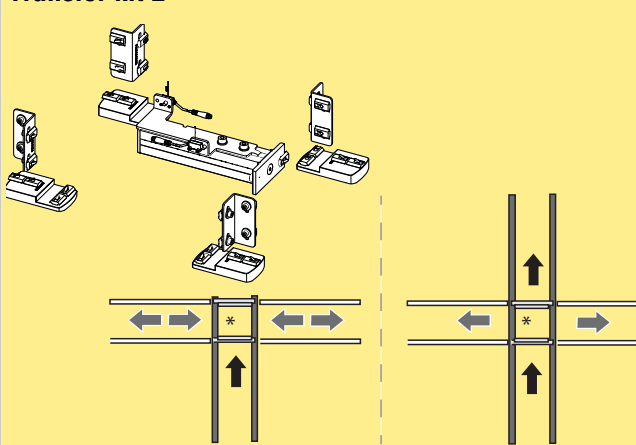

Transfer kit 2
without RFID
with RFID

**FLX1013281
FLX1013285**

Transfer kit 3

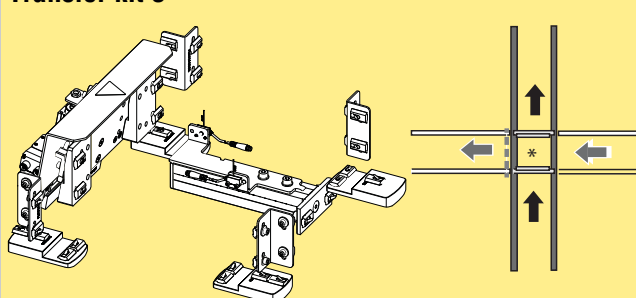

Transfer kit 3
without RFID
with RFID

**FLX1013282
FLX1013286**

MTT transfer kit components

These items are included in different transfer kits and are normally not needed to be purchased separately.

Stop

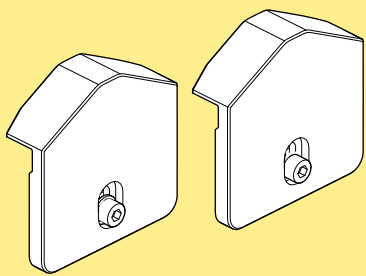

Stop **FLX1013309**
Contains two stops with fasteners.

Alignment unit

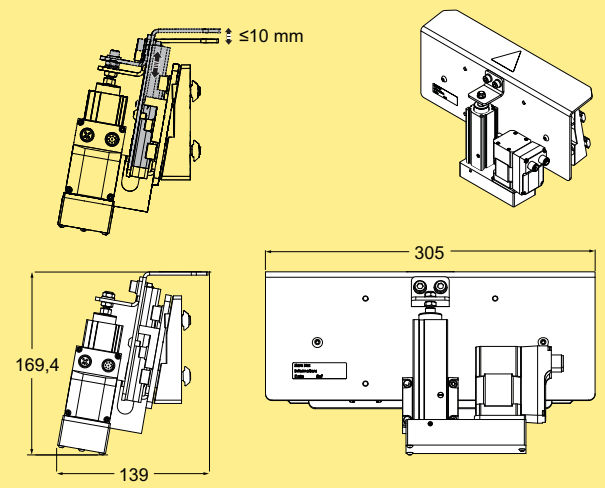

Alignment unit **FLX1011553**

Sensor kit

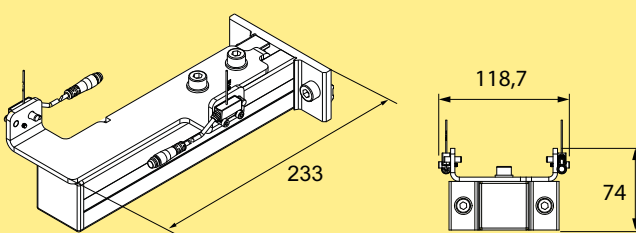

Sensor kit **XTPB VMT**
Including sensor kit with brackets

RFID reader/writer kit

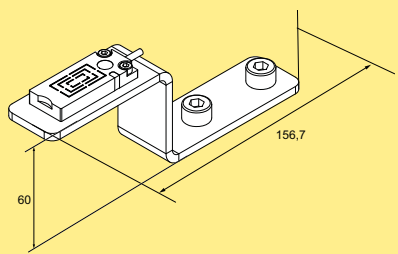

RFID kit **XTPB RFT**
Including reader kit with brackets



Support unit

The standard support unit XTUF SM01 is designed for use with both one and two level modules. It is easily mounted underneath the lowest frame level.

Solutions for mounting MTT modules at roof level are not available as standard.

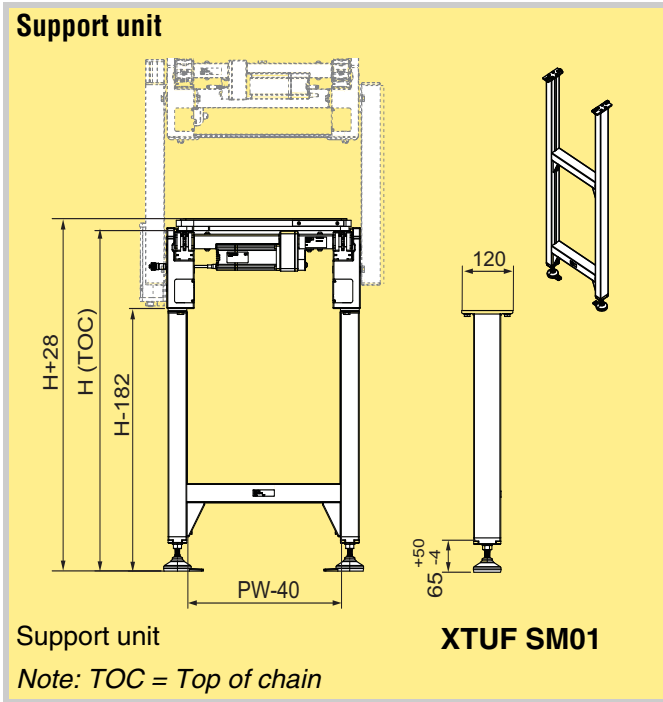

When the following questions has been answered, the support unit is fully defined:

Question	Choices (mm)	Description code
Pallet width	400	400
PW?	480	480
	640	640
H (Top of chain)?	$400 \leq H \leq 1920$ mm	H

Configurator output example:

Item No	Description
XTUF SM01	400-900

SCDC distributed controller

The SCDC is a configurable and robust field logic controller for decentralized applications. The SCDC device mirrors and translates PLC controls to the field equipment (e.g., sensors, CAN drives, and many more), and brings a standard interface for PLC controls as well as the standard interface for Digital Services (through MQTT).

The SCDC controllers are the connection to all electrical interfaces, such as motors, sensors and RFID readers, in the MTT modules.

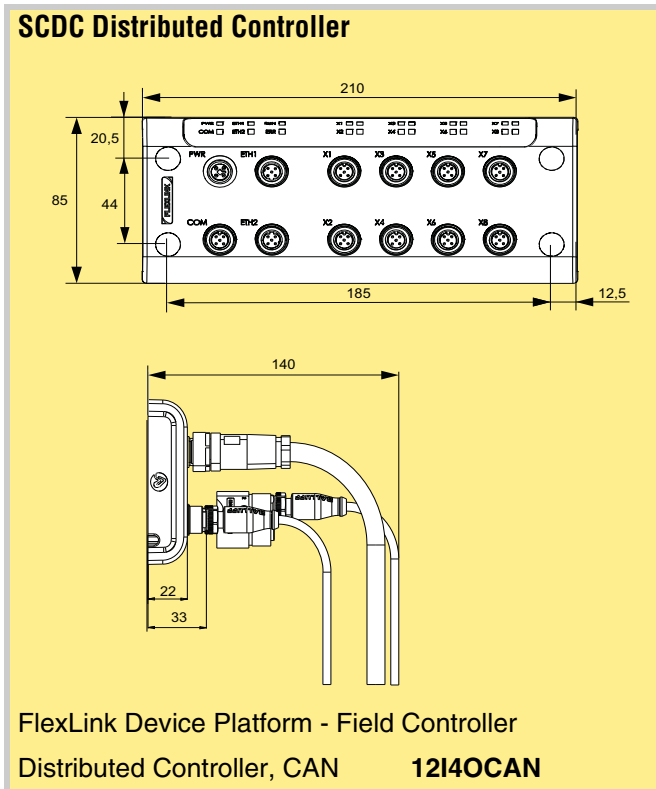

SCDC 12I4OCAN	
M12 connector	
PWR	24 V _{DC} , T-coded
COM	CAN
ETH	2 x Ethernet ports
X1-X4	4 x (IO-Link + DI)
X5, X6	2 x (DI + DI)
X7, X8	2 x (DO + DO)
Diagnose LED	1 x power 1 x Run 2 x LAN activity 1 x error, 1 x CAN activity 8 x IOs
Dimensions WxHxD [mm]	210x85x35
Max power loss [W]	4.5
Weight [g]	900
EMC	Conforms to IEC 61000-6-2 and IEC 61000-6-4
IP-rating	IP65 according to IEC 60529
Temperature [°C]	Operating ambient: -20 to +55 Storage: -20 to +60
Humidity [%]	Relative 5 to 95 no condensation
Compliance	CE
Included in delivery	1 x SCDC 12I4OCAN 4 x M5 x 16 - 8.8 - A2K screw 4 x end plugs M12 T code female power connector 4pin M12 connector dust caps

Power supply for 24VDC

Unit for free standing power supply of equipment in each MTT module. It has an incoming three-phase interface and 24VDC (2x12A) output interface.

Power supply kit

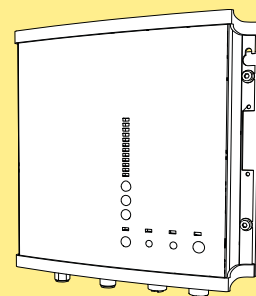

Power box

FLX1014913

Including bracket and fasteners

